

A GUIDE FOR VILLAGE CARPENTERS ON HOW TO BUILD A SAFER SHELTER



HOW TO BUILD A SAFER SHELTER

A Guide for Carpenters on how to build a shelter that will provide greater protection from future severe weather conditions.

INTRODUCTION

The people in Ayeyarwaddy and Yangon Districts are beginning to recover from the devastation caused by last year's cyclone Nargis. Now, many shelters are being repaired, upgraded and reconstructed. How should these shelters be built to better protect the families against the strong winds, heavy rains and high floods? UN-HABITAT, in collaboration with other agencies in the shelter Cluster, have identified the following ten main points to incorporate and ensure that every new shelter will better resist severe weather conditions and provide higher levels of protection.

- Build your house on stilts on the highest spot or your plot.
- Face the shorter side of a 'rectangular type' shelter towards where the strong winds normally blow from.
- Construct a roof with a steep slope (minimum 30 degrees), to reduce risk of being blown off.
- Limit the projection of the roof on all sides to maximum 18 inches.
- Fix the cover of the roof firmly to the frame of the roof.
- Fix rafters, purlins, tie beams and post plates firmly to the posts.
- Anchor the strong posts with solid footings to the ground.
- Strengthen your shelters against the winds with braces on each side.
- Maintain the important parts of your shelter regularly.
- Re-tighten and repair your shelter before the monsoon starts.

These rules apply to all types of shelters, whether building with bamboo and fixing with ropes or if constructing with palm trunks or timber joined by nuts and bolts. These rules do not only apply to constructions after cyclone Nargis, but to any shelter construction you and your village members engage in from now on.

This Guide explains the special features, techniques and recommendations and shows how they can easily be applied for any safe construction. Read the guide, discuss with your community, seek advice from other carpenters and build a safer shelter.

A shelter that is built using the methods described in this booklet will provide increased protection from wind and rain and flood, and will enable the families to sleep at night in the knowledge that they are in a strong and safer shelter.

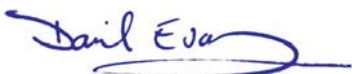

David Evans, UN-HABITAT

A GUIDE FOR VILLAGE CARPENTERS

Contents	Page
Introduction	4
Chapter 1. General points on shelter construction	6
1.1 Role of a carpenter	6
1.2 DRR requirements	6
1.3 ABC Principle	8
1.4 How to check the stability of an existing shelter	9
1.5 Shelter upgrading	10
Chapter 2. Construction Materials	12
Chapter 3. Tests to check resistance of shelters	17
Chapter 4. Construction Guidelines	19
Conclusion	31

Published by: UN-HABITAT, Myanmar, June 2009

Prepared by: UN-HABITAT Training Team, Pyapon

Introduction

Construction of new shelters and improvements of the stability of existing shelters are two important community activities, especially after the Cyclone Nargis which destroyed a large number of shelters. As the shelters in the delta region are mainly made out of timber or bamboo, the role of the **Village Carpenter** is very important. Their services and advice are sought by almost all families in order to build new shelters or to improve existing shelters. Especially in the delta area, which is prone to seasonal rains, storms and floods, the carpenter, has an important role to play: to improve the existing shelters and to construct new shelters in such a way that they can better resist to the elements. While resistance to cyclones of the magnitude of Nargis is beyond the scope of the village carpenter, he should be in a position to advise households if their shelters can withstand the usual rains, storms and floods - or how the shelters can be improved to better protect the families in the rainy season and eventually, if required, build a new, more resistant shelter.

This Guide offers an opportunity for Village Carpenters to acquire additional skills and knowledge. The Guide includes the necessary technical information and guides the carpenter methodically through the total process of making shelters more resistant to natural elements, using materials available in the region, either by simple upgrading activities or by constructing of new shelters.

The guide is not necessarily meant for reading from start to end. It may serve as a source of reference for particular shelter construction or repair activity envisaged in relation to a given shelter.

Carpenters who are thorough with the contents of this Guide will also be in a position to act as advisors to householders and village committees engaged in shelter construction. These carpenters will contribute in an essential manner to the village efforts to be prepared for the forces of nature during the rainy season in the delta region.

These skilled carpenters are invited to share skills and knowledge acquired through the guide with their colleagues and other facilitators.

A new shelter complying with DRR requirements



Chapter 1. General points on shelter construction

1.1 The role of a carpenter

A carpenter is called upon to provide **four** services:

- Advise households how they can make their shelters safer.
- Improve shelters resistance before rainy season.
- Upgrade the safety and quality of existing shelters
- Build new shelters

1.2 Disaster Risk Reduction (DRR) Compliance

In order to reduce the risks of loss of lives, livelihood and assets caused by heavy rains, strong storms and high floods, the carpenters have to observe some main points and follow important technical guidelines when they upgrade any existing shelter or build new safe houses.

In technical words this means: DRR compliance of a shelter is its ability to retain its original characteristics after being subjected to natural elements and continue to provide safe shelter to its occupants and assets.



Points to observe	Disaster Risk Reduction
Build on higher/safer ground	More safety from floods
Short face of the house to windward direction	More stability against winds
Roof pitch – minimum 30 degree	Proper roof drainage Prevents roof blowing away
Roof projection – not more than 18" from all sides	Prevents roof blowing away
Roof cover firmly fixed to rafter and purlin	Keeps roof cover intact against wind forces
Rafters, purlins, tie beams and post plates have to be securely fixed to posts	Prevents structural failure
Provide bracings	Makes structure wind resistant
Posts firmly anchored to ground	Prevents the posts (and even the entire shelter) to tilt, sway or be blown away
Maintain/repair regularly	Extends the durability of shelter
Repair/upgrade before monsoon	Ensures that shelter remains resistant and safe

1.3 ABC Principle

The general requirements in shelter construction in regard of DRR compliance is summarized in a simple abbreviation: the ABC Principle.

A = Anchoring

Every part of the structure must be tied back to some secure point which is capable of resisting all applied forces.



B = Bracing

Every part of the structure must be held rigid so that it cannot **tilt, slide or rotate**.

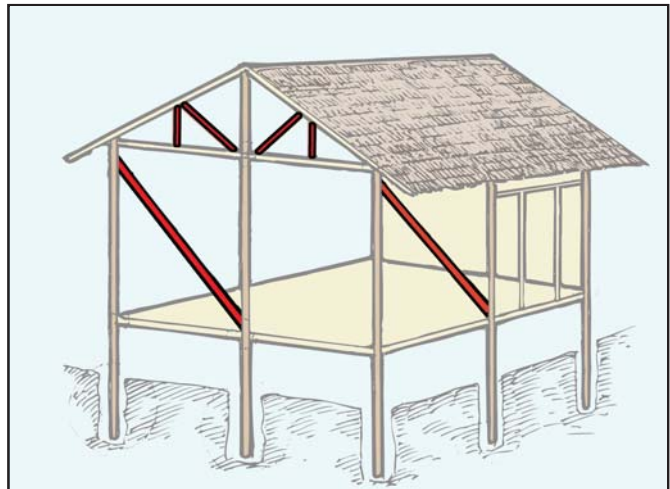

C = Continuity

Every part of the structure must be properly connected to every other member.

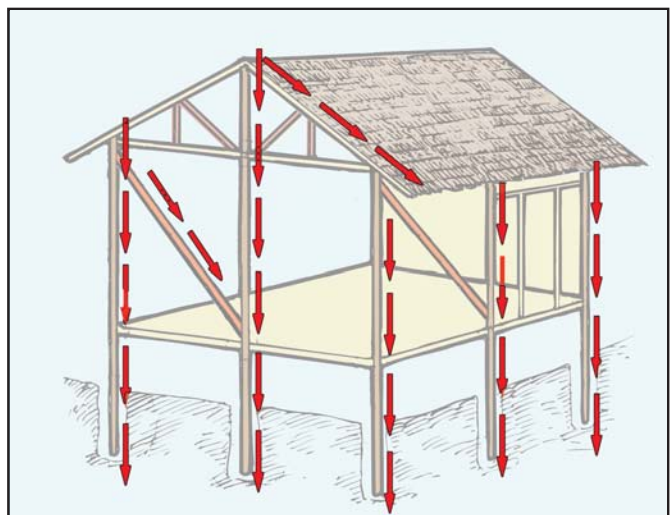

1.4 How to check the stability of an existing shelter

Prior to planning any repair work or eventually a new construction to replace an existing shelter, check the shelter for stability.

The stability of a shelter can be assessed by four checks, which are made best when the household owner is assisted by a Village Carpenter.

- Is the majority of post bases decayed?
- Is the shelter tilted more than 5 degrees?
- Is the roof sagging?
- Are bracings provided?

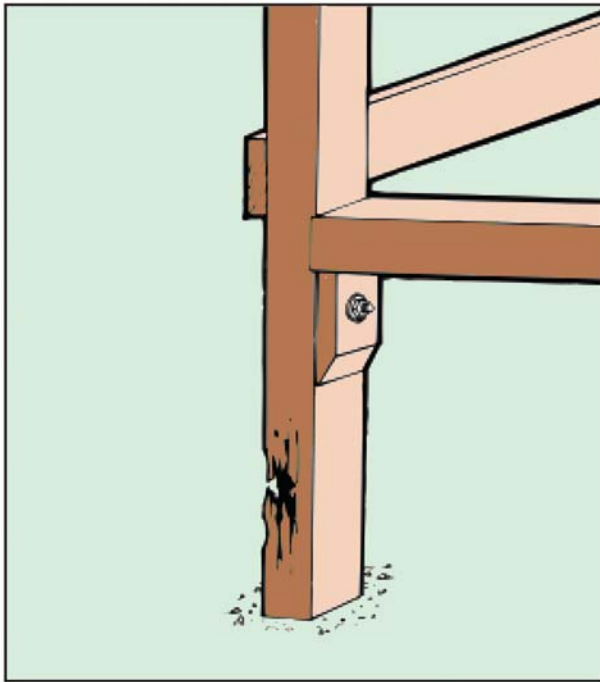

Decayed posts ▲

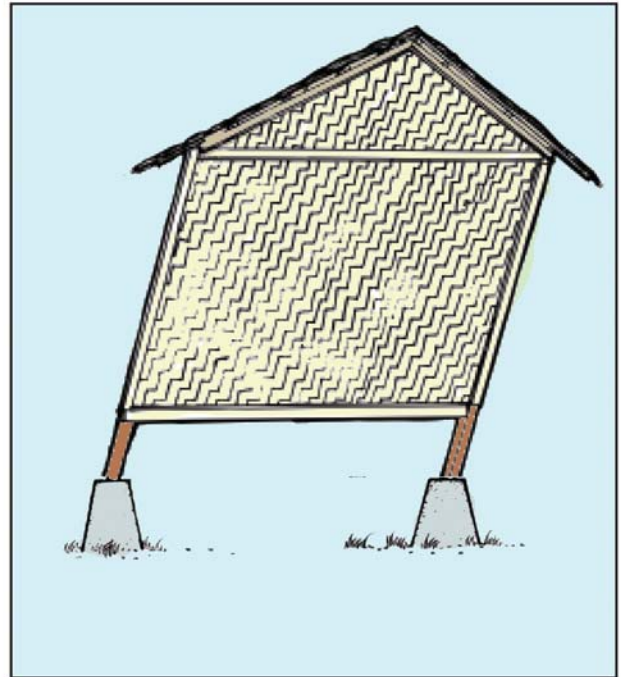

Tilted shelter ▲

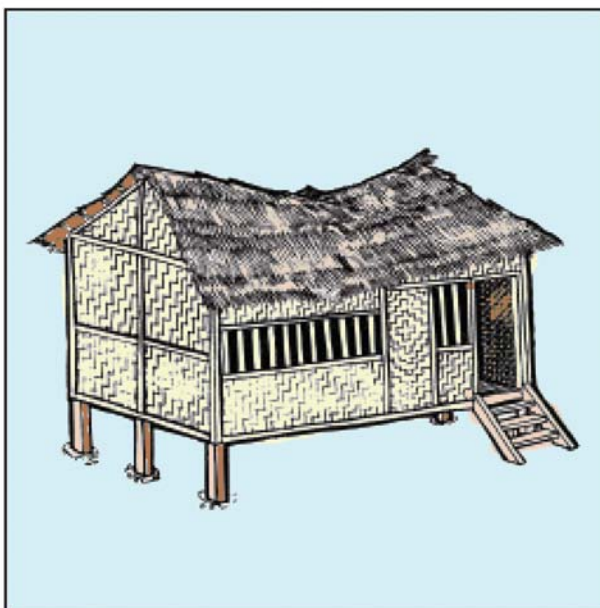

A sagging roof ▲

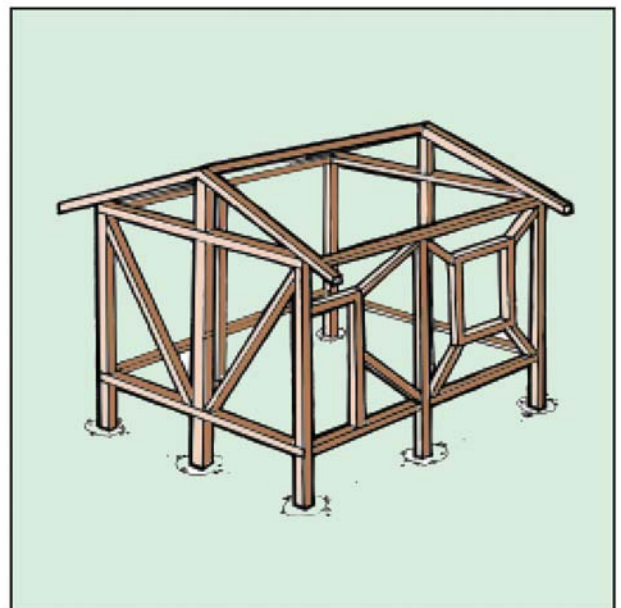

Braces ▲

1.5 Shelter upgrading

Existing shelters shall be upgraded to better resist and thus better protect the families against heavy rains, strong storms and high floods. Shelter upgrading work involves:

Upgrading	Remarks
Repair or replace roof cover and top mat	Rearrange or replace roof cover and top mat.
Replace weak posts	To ensure good anchoring, weak posts should be totally or partially replaced. Temporary supporting is required while the posts are replaced.
Replace weak beams, rafters, purlins	Rafters and purlins should be replaced prior to work on roof cover. When beams have to be replaced, the structure should be temporarily supported.
Introduce or add bracings	Additional braces make the shelter frame more rigid and resistant to winds. It also helps to straighten tilted structures.
Repair floor deck	Clean both top and bottom. Re-nail/rerope loose slats. Replace decayed parts.
Repair wall cladding	Clean both internal and external faces. Provide additional braces if required. Renail loose parts. Paint with preservatives.
Tighten loose joints	Check all frame joints. Tighten bolts & nuts. Drive loose nails. Use new nails if required. Rerope if ropes are decayed.

Upgrading	Remarks
Provide safe anchoring	Check all structural members. Ensure that all are properly anchored to resist all applied loads.
Reuse available/salvaged material	Before purchasing new material, consider possibility of re-using available or salvaged material. Keep dismantled good material properly stacked for future use.



Carpenter repairing a shelter ▲

Chapter 2. Construction Materials

The choice of construction material is to be made in careful consideration of: (a) Availability, (b) Suitability, (c) Quality, (d) Cost.

Characteristics and suitability of some major construction materials.

Sawn Timber

Used as:

- Posts, beams, joists, bracings
- Rafters, purlins
- Floor boards
- Wall cladding
- Valance & Barge Boards

Characteristics:

- Variety of grades ranging from strong to weak and durable to non-durable.
- Gives a neat finish
- Available in many common sizes
- Many species are resistance to termite/pest attack
- Easy to work. Can be assembled with conventional timber joints. Can be nailed or bolted
- High cost

Consider required strength and durability for intended use

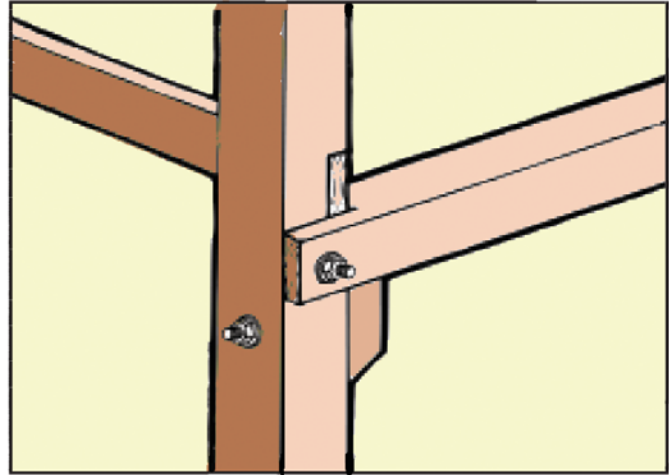

Sawn timber post & Joist joint with nuts & bolts ▲

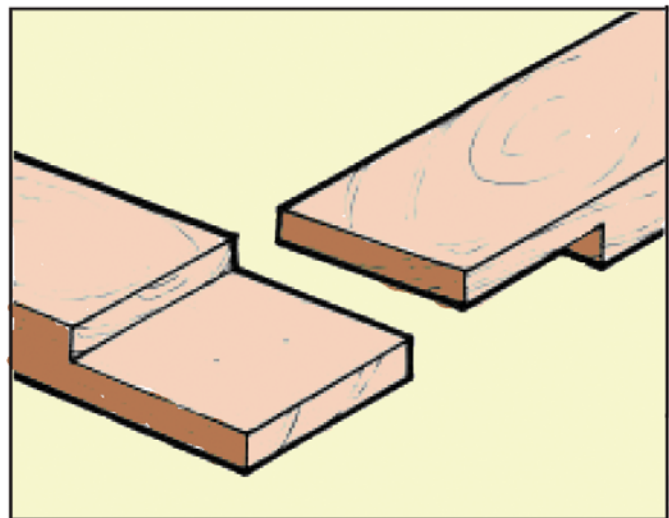

Halving joint ▲

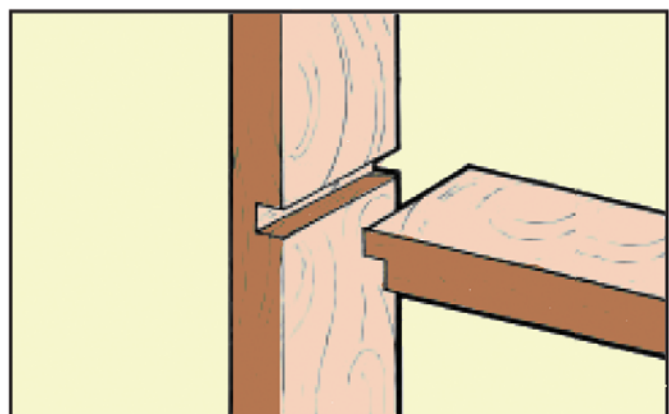

Sawn timber post and joist joint ▲

Toddy Palm

- Posts, beams, joists, bracings
- Rafters, purlins

Characteristics:

- Strong and durable
- Hard outer layer/soft inner layer
- Resistant termite/pest attack
- No neat finish since the trunk is split and not sawn
- Adequate stocks available
- Difficult to work
- Can be nailed or bolted
- Relatively low cost

Ensure that the soft core part of the trunk is completely removed.



Toddy Palm ▲

Bamboo

- Posts, Beams, Joists
- Rafters and Purlins

Characteristics:

- Low cost
- Susceptible to termite/pest attack
- Strong for most locations of the structure
- For main structure difficult since proper jointing is complicated.
- Round section of bamboo makes anchoring difficult.
- Splits easily.
- Very good for rafters, purlins.

Split bamboo is used for floor deck and wall cladding

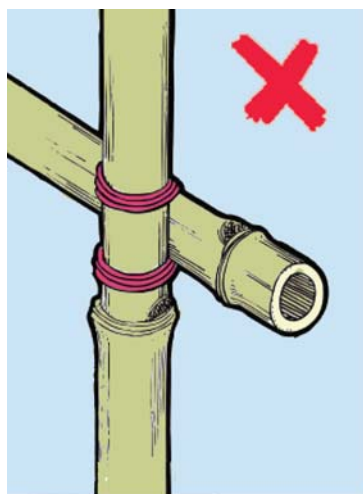

Now used fixing method ▲

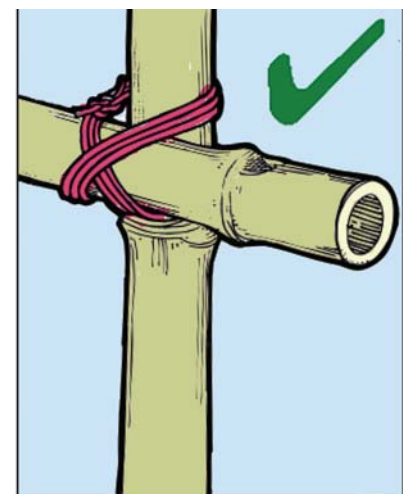

Improved method of fixing bamboo joints ▲

Jungle Wood

- Posts, beams, joists
- Rafters and purlins

Characteristics:

- Relatively low cost.
- Strong structural material.
- Some species are very durable.
- Round and usually tapering in section.
- Can be used for most locations of the structure.
- Jointed with bolts & nuts, nails or roping.

Select larger diameter trunks from durable species.

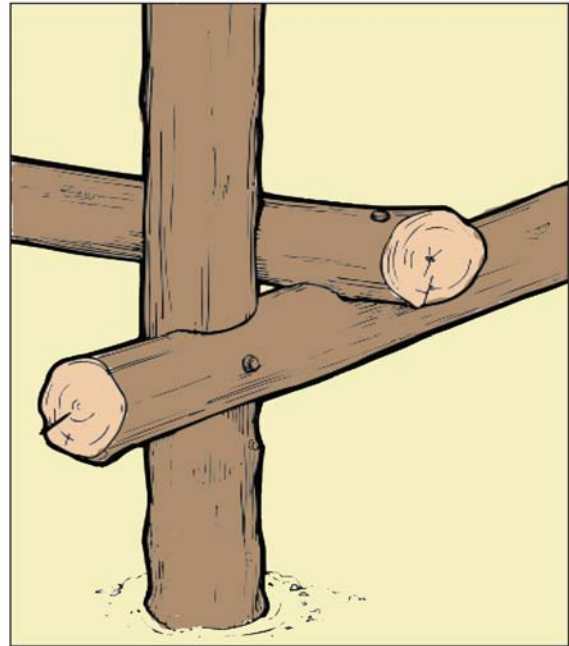

Jungle wood joint between post and joist. ▲

Nipa palm thatch

Used for roof cover and sometimes for wall cladding.

Characteristics:

- Freely available, but seasonal.
- Requires preparation prior to covering.
- Provides a thick waterproof cover if properly laid.
- Requires firm fixing to rafters/purlins to avoid blowing away due to wind.
- Low cost.
- Rainwater harvesting is difficult.



"Dani" covered roof ▲

CGI Sheet

- Roof cover
- Cladding

Characteristics:

- High cost.
- Ready for use.
- May cause safety hazard if not properly fixed.
- Liable to corrode.
- Light weight.
- Easy to lay.

Specifications:

CGI sheets 30 or 32 gauge are suitable for normal shelter roofs.



Roof with CGI-sheets ➤

Sawn timber planks

- Floor deck
- Doors & Windows
- Valance and Barge boards

Characteristics:

- High cost.
- Gives a neat and waterproof, even finish.
- Strong.

Sawn timber planks ➤



Split bamboo

Used for floor deck

Characteristics:

- Most common type of floor in the delta.
- A well conversant material.
- Low cost.
- Does not provide an even floor surface.
- Installation is simple.

Purchase large diameter bamboo for floor deck work.



House with Bamboo floor mat ➤



Arricanut strips (split trunks)

Used for floor deck

Characteristics:

- Split arricanut trunks.
- Low cost.
- Not an even floor surface.
Nailing or tying with strings.

◀ *Different bamboo mats designs*



Weaved bamboo mat for wall

- Most common wall cladding in shelters in the delta area.
- Quality of mat depends on the thickness of veneers.
- Weaved in different designs
For strength and durability, select mats weaved from thick strips.



▲ *Setting bamboo mat wall*

Chapter 3. Check resistance of shelter construction

The following three tests shall prove on site if the constructions are properly done so that the shelter will resist to the natural forces.

Bending of column posts

To test the ability of column posts to resist high winds. If a post firmly buried in ground if pulled by 02 people (average force of 130 kg) returns back to its original position, it can be considered to withstand normal wind forces.

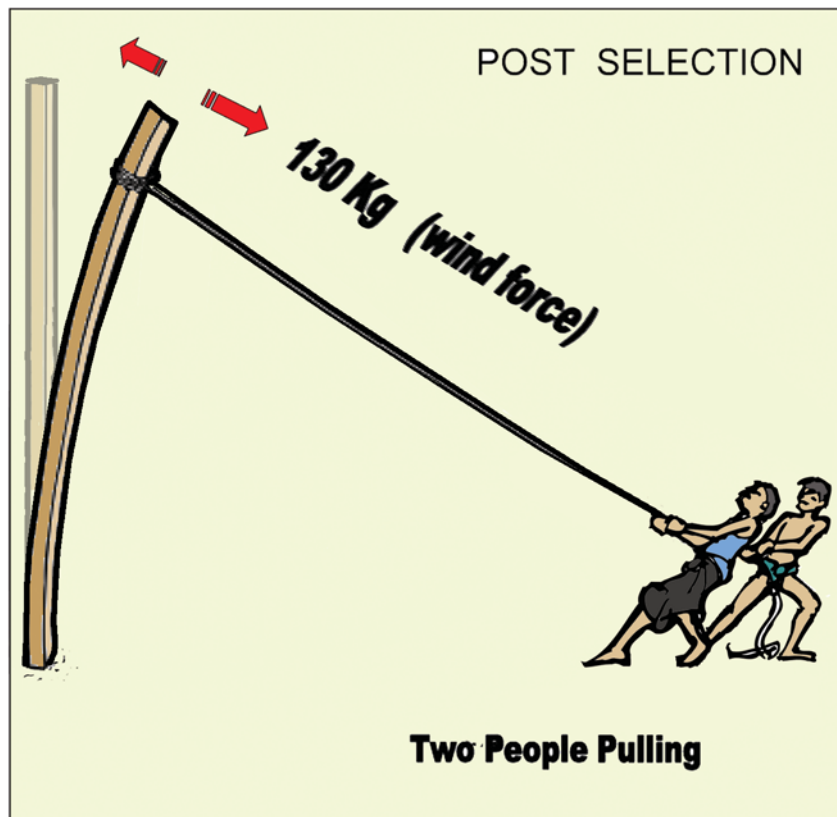

Resistance for uplifting of post footings

Are the post footings well anchored in the ground? Using rope and cross bar two people will pull out a post footing buried in soil. If the force exerted by the two people cannot move the footing, it is safe from uplifting. If it comes loose the area around is not compacted properly and should be recompacted.

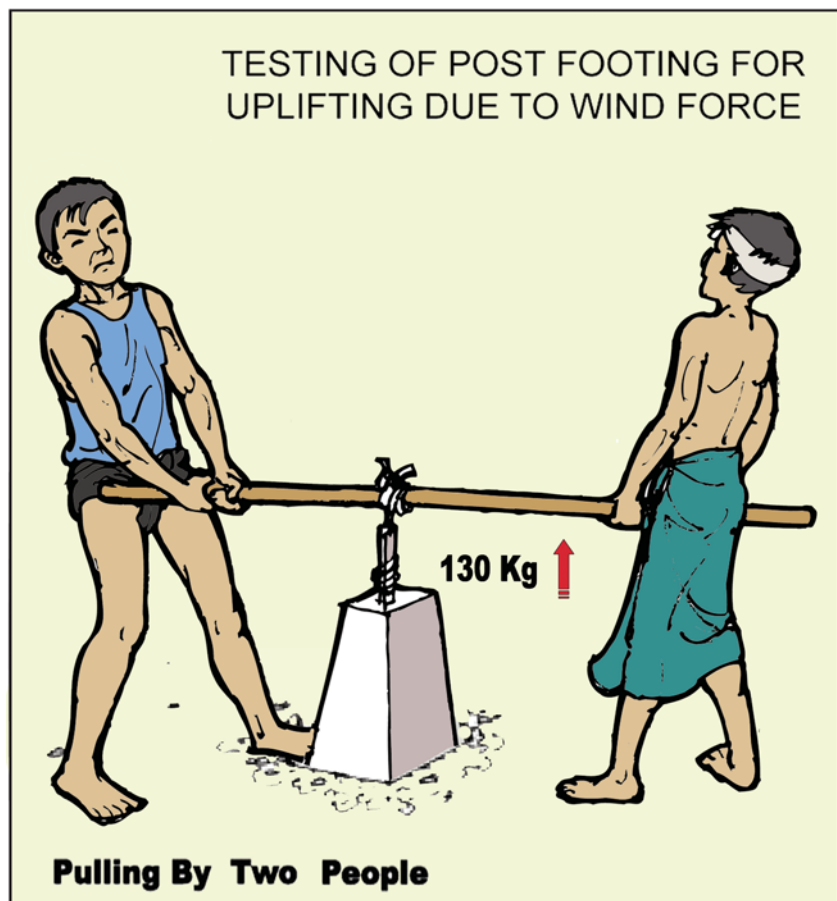

Testing soil at the bottom of post footings

Is the soil hard and compacted enough to place footings/posts? Hold a 5 kg crow bar 3 feet above ground, directly above the pit, with its pointed end downwards. Drop it freely on bottom. If the penetration of the crow bar is less than 6", the soil is hard enough for placing the footing. If not it should be improved by consolidation or new filling.

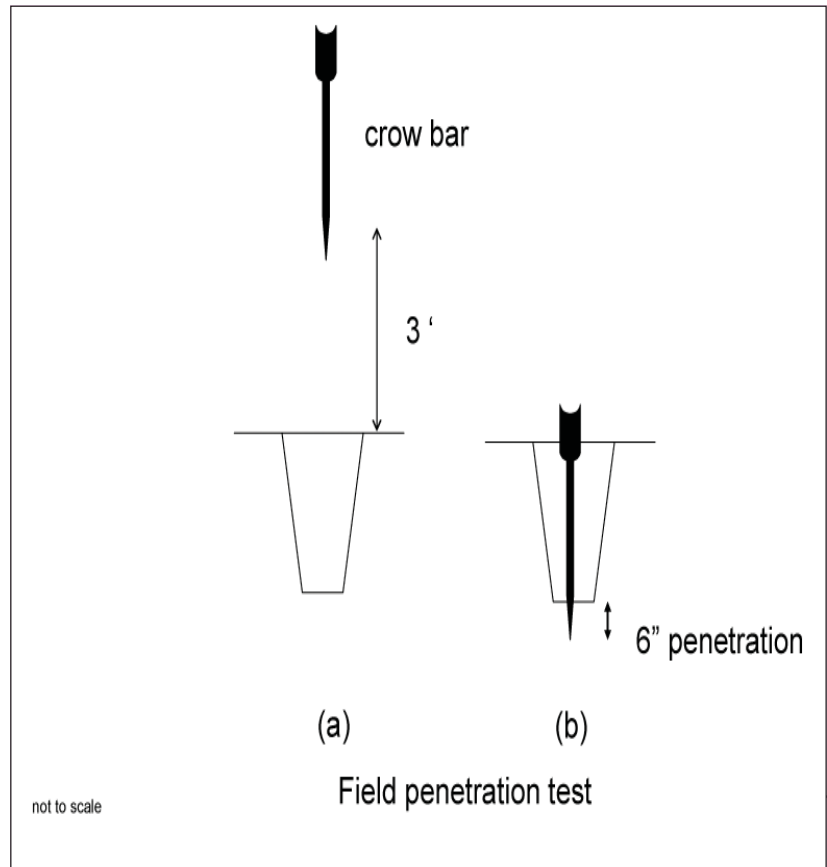

Fixing floor joists ▲

Chapter 4. Construction guidelines

A good carpenter has to produce a safe, strong shelter with good finish. This can only be achieved when these good work practices are applied:

1) Site preparation

A typical shelter site may require all or only some of the following activities:

- Clearing
- Leveling
- Providing access to site
- Allocation of space for material storage
- Water supply
- Waste disposal
- Fencing

2) Setting out

In timber and bamboo construction setting out is to mark the location of centers of all posts on ground.

1. Select shelter location.
2. Use wooden pegs and strings for drawing lines.
3. Set out base line.
4. Set out right angles (3:4:5)
5. Set out other lines perpendicular to base line.
6. Complete the rectangle/s.
7. For accuracy: measure diagonals.



Men identifying a site ▲

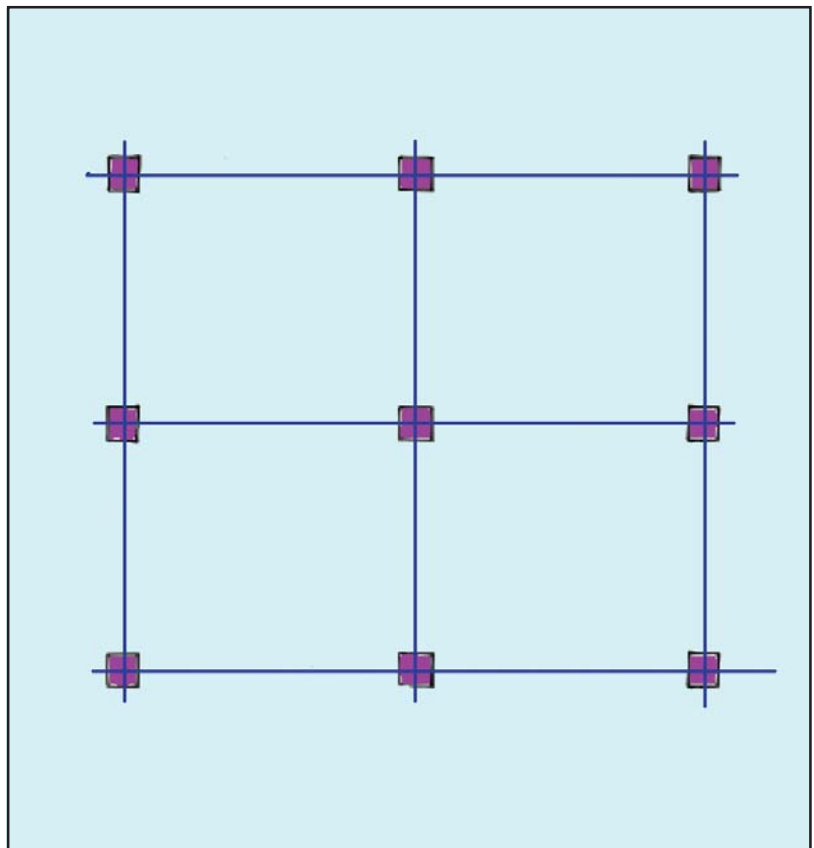

Center line network ▲

3) Excavation for posts

Mark location of column posts at each intersection of setting out lines.

From the centre, mark width of the pit.

Excavate using auger or crow bar and shovel. Stack excavated material away from opening, Excavate to required depth. Bottoms of all pits should be at the same level. Use water level for leveling depth of excavation.

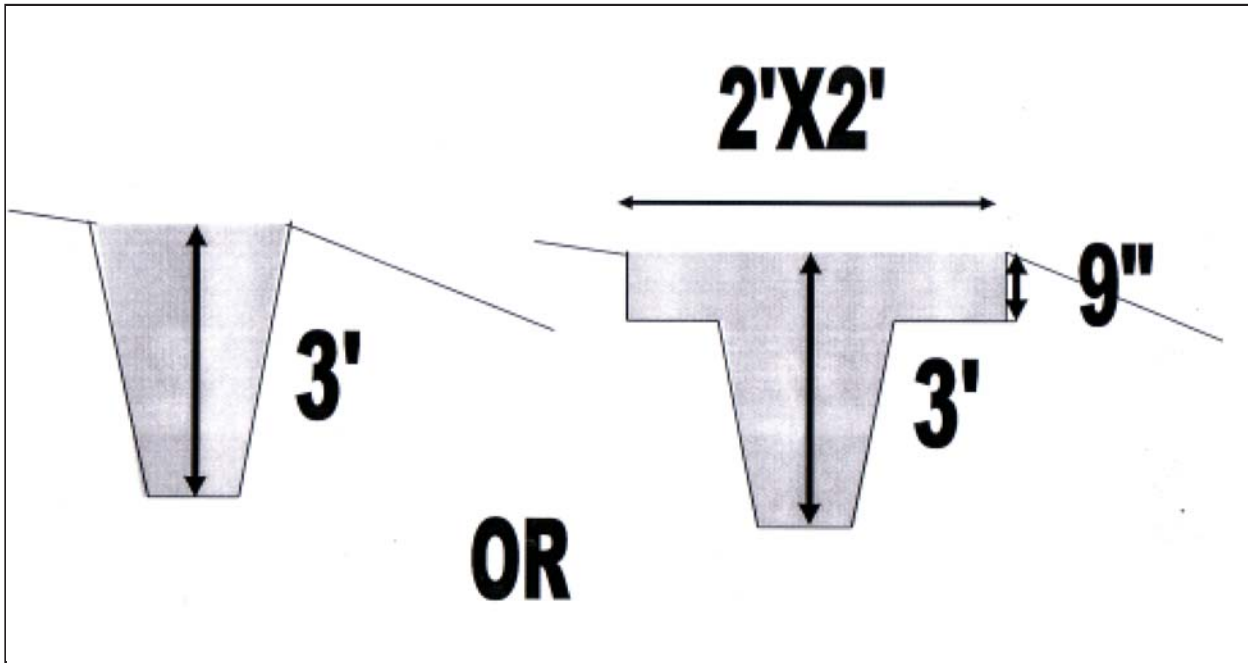

Excavation for posts ▲

4) Preparation of posts

Before erecting posts, prepare them to receive floor joists, post plates, ridge plate and tie beams. This is done by providing chases at appropriate heights to accommodate joists and posts. Provision of chases makes the joint secure and share the load.

Give attention to provide proper roof slope in cutting chases for ridge plate.



Cross joist and long joist mounted on post with nuts & bolts and cleat ▲

5) Erection of posts

Prepared posts can be erected in the excavated pits at proper locations. After erecting, the posts should be plumbed and held firmly in position with temporary props.

Compaction of the base of the post is **not** after erection, but postponed until the main structure is assembled. This provides room for any adjustments during construction.



Posts held in position with temporary supports ▲

6) Mounting joists of the frame

At floor level: (a) Cross joists; (b) Long joists, (c) Floor joists

At roof level: (d) Post plates, (e) Tie beams and (f) Ridge plate

The joists are placed in pre-prepared slots (chases) and fixed using bolts & nuts, nails or ropes (mainly if bamboo is used).

Some construction details from traditional houses

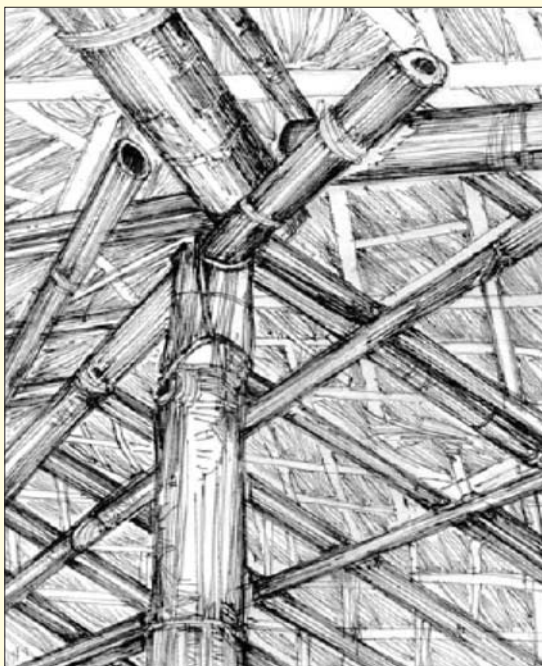
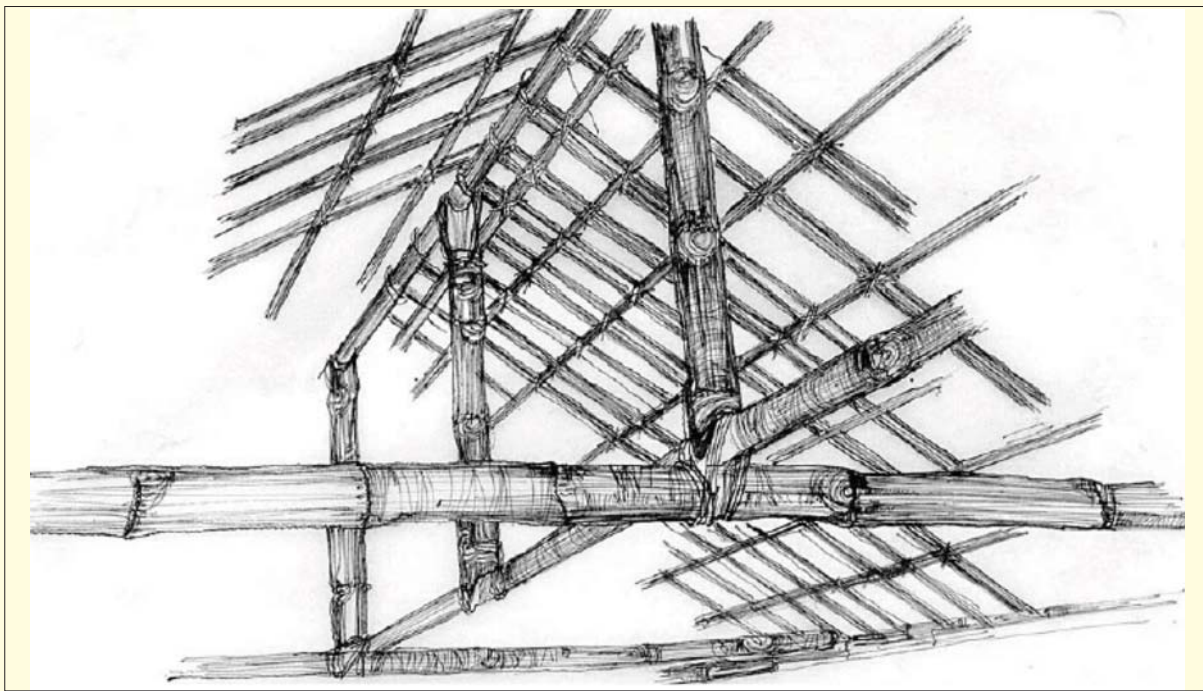

All drawings kindly provided by IFRC/MRCS

7) Erecting rafters

Rafters should be laid at the appropriate angle to provide adequate pitch. Recommended minimum pitch is 30 degrees.

During preparation of posts, the pitch has already been considered when marking the top chases.

Rafters are fixed with top end on the ridge plate and the lower end on the post plates. Bolts & nuts, nails or rope can be used, depending on the type of construction.

Pairs of rafters are fitted together on ground at the appropriate roof angle prior to fixing.



Pair of rafters being erected ▲



All rafters in position ▲

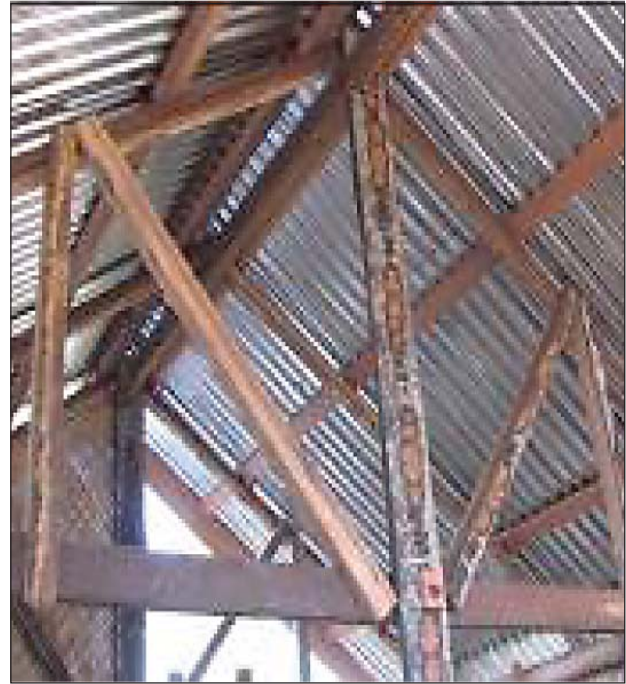

Bracings to rafters ▲

8) Fixing roof purlins (reepers)

Roof purlins (runners) are fixed on rafters by nailing or roping. Blowing away of roof purlins (runners) in high winds is prevented by providing twisted steel straps nailed to rafters.



Steel straps to anchor runners to rafters ▲

9) Laying roof cover

Nipa Palm thatch ("Dani")

Nipa palm requires rafters at 9" – 12" centers for firm fixing. Starting from the lower end of the roof, thatch is laid on rafters and tied securely using bamboo strips. Roof ridge is covered by thatch and securely fixed with coconut fiber or plastic ropes.

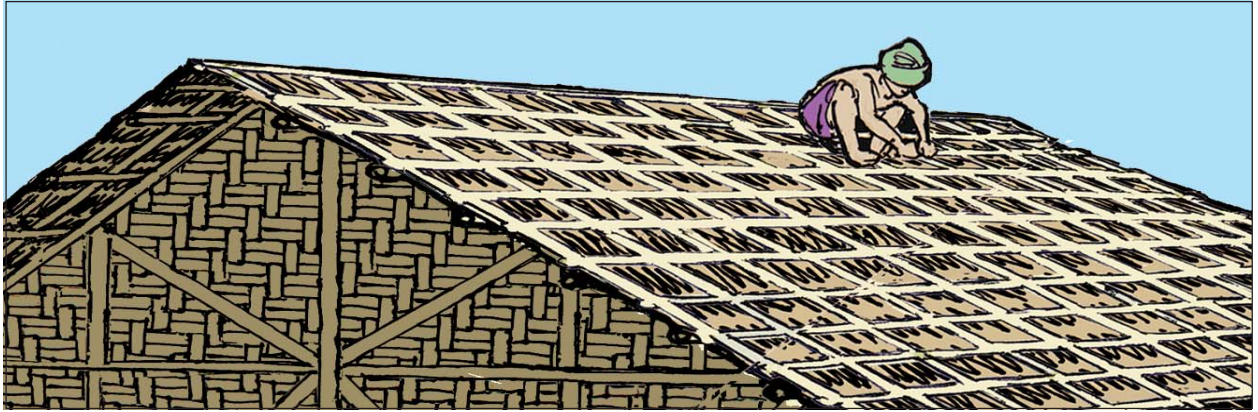

"Dani" roof viewed from outside ▲



"Dani" roof viewed from inside ▲

CGI sheet

Adequate lap (min. 6") should be provided between rows in laying CGI sheet. The bottom row is first laid to a stretched line and then the top rows.

The usual practice in the delta is to use GI cup nails to fix sheet. Nails are used on every other corrugation. Obviously nails should be driven only on top corrugations to prevent leakages.

A good practice, though more expensive, is to use "J" bolts to fix sheet.

For CGI roof the ridge will be made out of plane GI sheet formed to appropriate roof angle. This too is nailed using cup nails. But "J" bolts are preferred.



CGI sheets fixed ▲

J clips and
Cup nails
used for
fixing of CGI
sheet



10) Valance and barge boards.

7" x ¾" valance and barge boards are nailed to the ends and sides of rafters for protection of rafters and better appearance.

11) Rain water gutters

6" diameter semi circular UPVC gutters are fixed to the valance board using brackets. This serves two purposes – 1. Prevents splashing of rain water on ground around posts and 2. Provides rain water harvesting.



Provides rain water harvesting ▲

12) Floor deck

Preparation of bamboo mat for floor deck Selected large bamboo cut to required length and split to form the floor mat.



Splitting bamboo for floor deck ➤

13) Laying of floor deck

The prepared mat is laid on floor, cut around posts to perfect fit and nailed to the floor joists.



◀
*Preparing
a bamboo
floor mat*

14) Framework for walls

Vertical, horizontal and inclined timber nailed to posts, joists and post plates form the framework for walling. While supporting the wall cladding, the frame also acts as bracings.



Framework for wall cladding ▲

15) Doors and window frames

A shelter should have a minimum of two doors and two windows.

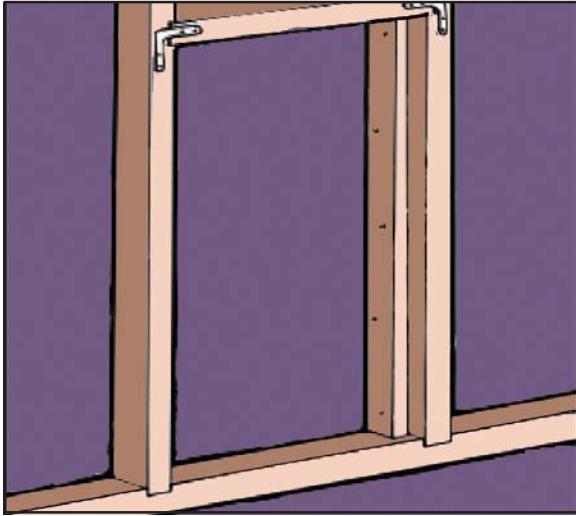

Door slash ▲

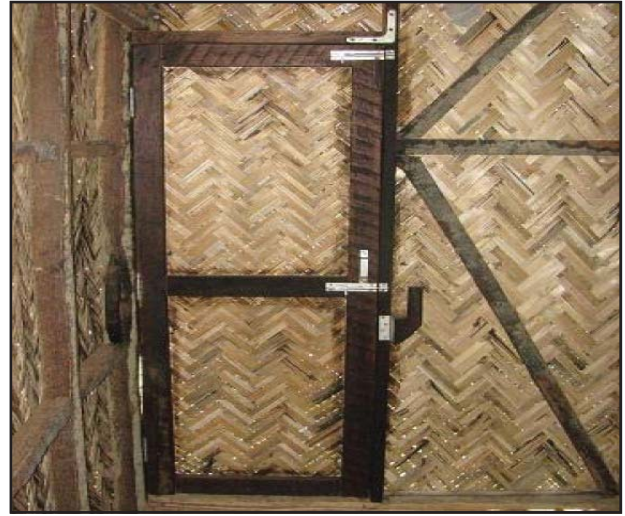

Door ▲

Door and window frames are made out of 3" x 2" sawn timber. The frame is fabricated using cross half lap and end half lap joints, with the members nailed.

Once fabricated, the frame is mounted on the door/window opening using butt hinges and screws.

Paneling the door/window sashes is after installation of wall cladding.

Door/window paneling is usually made of same bamboo mat used for walls.



Window ▲

16) Access to the shelter

A flight of steps or a ramp has to be provided for access to the stilted shelter. Access should be provided to both front and rear doors. The same material used for shelter frame (sawn timber, toddy palm, jungle wood or bamboo) can be used for access construction.

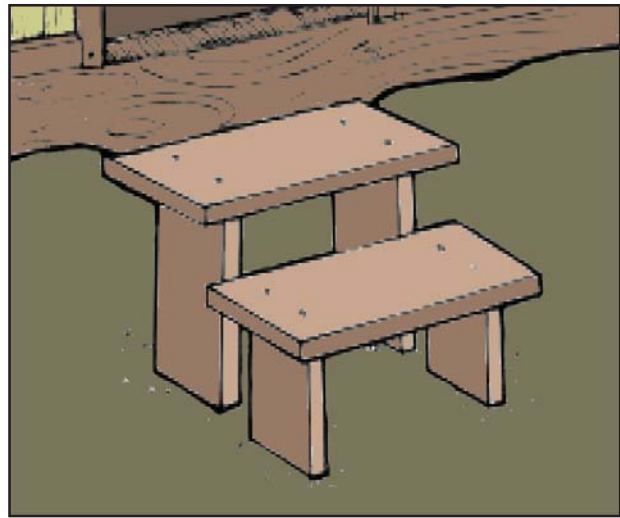

Flight of steps ▲

A ramp is preferred if the household consists of disabled persons, very old persons or very small children. If a ramp is to be erected the inclination should not be more than 1 ft height in 4 ft length.



Ramp ▲

In steps the vertical height between two adjacent steps is called “Rise “ and the horizontal dimension of a step is called the “Going”.

In determining the size of steps the following formula can be used:

$$2 \times \text{Rise} + \text{Going} = 23''$$

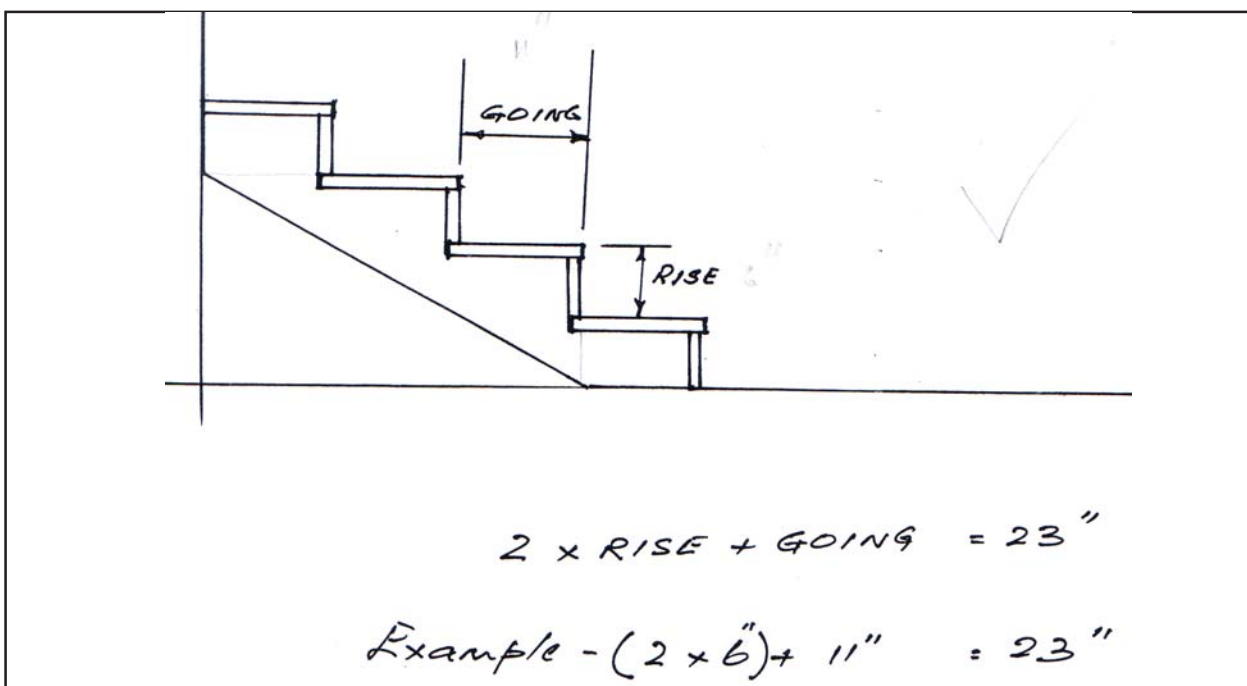

Ratio of rise / going at steps ▲

Conclusion.

It is hoped that this guide serves as a handbook for carpenters in the delta region who want to upgrade their knowledge and skills in shelter construction.

Starting with the role of a Carpenter, the guide has explained DRR requirements of shelter construction, common materials used for construction in the delta region, few checks in shelter construction and the steps involved in the construction of a typical shelter using timber and bamboo. While the reader's attention is drawn more to the importance of building safe shelters, the guide deals with methods for constructing shelters that could withstand the common elements causing disasters in the region, namely heavy rains, floods and storms. The same methods improve the stability of shelters against earthquakes. Protection against fire has been left out as most households and communities are well prepared to face fire hazards.

Shelters upgraded or constructed following the guidelines explained in this **Carpenter Guide** will much more likely withstand the mentioned elements so that the risk that these elements will cause high loss of lives and assets will be much reduced. By this, the means of livelihood will be less damaged; the risk of a serious set back of the development of the economy and society is reduced. This is true **Disaster Risk Reduction**.

To build back safer is thus a most important objective, that should be the concern of each family by maintaining and improving their shelters in view of upcoming rainy seasons and by upgrading/re-constructing their instable shelters. This is addressed in the **Household-Guide**.

As such maintenance and upgrading concerns almost every family, it is not only an individual, but a collective task of the entire village. How to sensitize the community and organize the steps to implement such an upgrading with their own resources and supported by additional funds is explained in the **Village Shelter Committee Guide**.

All 3 Guides are interlinked and cover the different parts of **Building Back Safer**. We recommend to take note of all **3 Guides** in your village.

Disaster Risk Reduction (DRR) Compliance

Points to observe	Disaster Risk Reduction
Build on higher/safer ground	More safety from floods
Short face of the house to windward direction	More stability against winds
Roof pitch – minimum 30 degree	Proper roof drainage Prevents roof blowing away
Roof projection – not more than 18" from all sides	Prevents roof blowing away
Roof cover firmly fixed to rafter and purlin	Keeps roof cover intact against wind forces
Rafters, purlins, tie beams and post plates have to be securely fixed to posts	Prevents structural failure
Provide bracings	Makes structure wind resistant
Posts firmly anchored to ground	Prevents the posts (and even the entire shelter) to tilt, sway or be blown away
Maintain/repair regularly	Extends the durability of shelter
Repair/upgrade before monsoon	Ensures that shelter remains resistant and safe