

# DISASTER RISK MANAGEMENT - DOCUMENT SERIES

## Awareness, Training and Education

### *Seismic Safety of Non-structural Elements & Contents of Hospital Buildings*

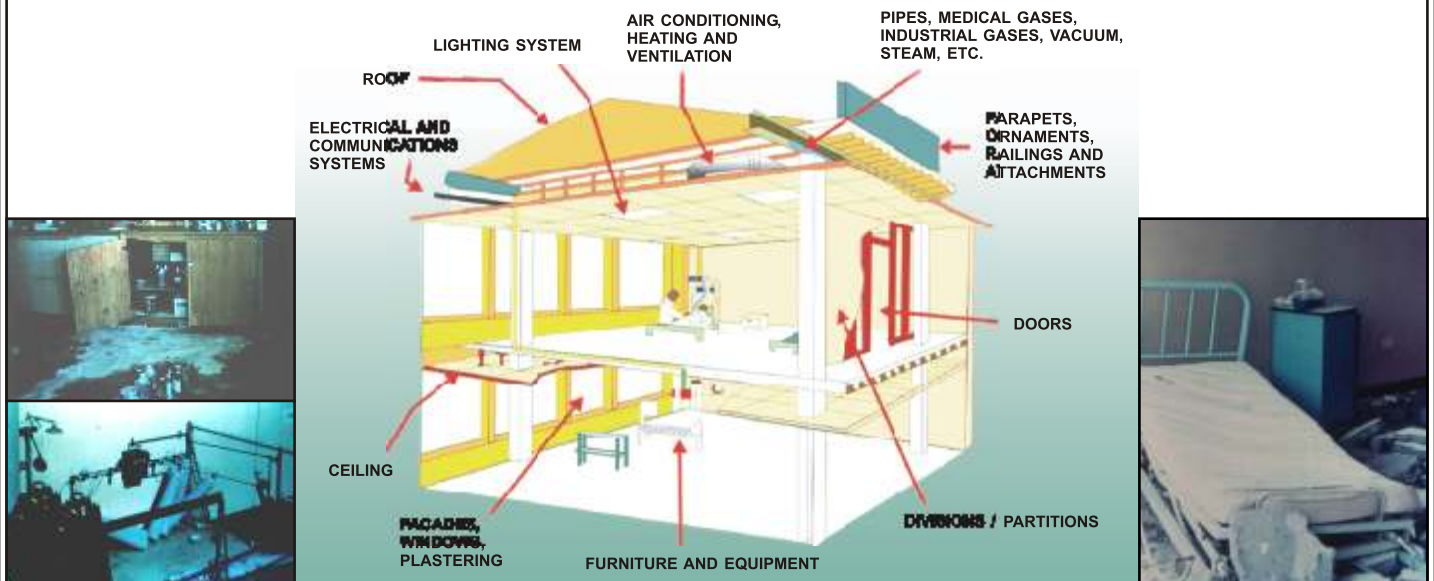

# SEISMIC SAFETY OF NON-STRUCTURAL ELEMENTS AND CONTENTS IN HOSPITAL BUILDINGS



सत्यमेव जयते

Prepared Under

GoI – UNDP DISASTER RISK MANAGEMENT PROGRAMME



India



**USAID** | **INDIA**  
FROM THE AMERICAN PEOPLE



From  
the People of Japan



**Australian Government**  
**AusAID**



United Nations  
International Strategy for Disaster Reduction

## **Preface**

After any large scale earthquake disaster the demands on the hospitals are increased many folds including small, medium and severe injuries to people requiring various treatment from first aid to serious operations. During the Kachchh earthquake of 26<sup>th</sup> January, 2001, 1,77,000 persons got injured besides 13,800 persons killed. The only large civil hospital at Bhuj got completely demolished during the earthquake killing more than 200 persons including doctors, nurses, patients, visitors and hospital staffs. More than 17,000 operations were performed in tents with make shift arrangements. To prevent the total collapse of hospital buildings structural assessment as well as retrofitting is to be carried out. In Delhi GTB hospital in east Delhi and the All India Medical Institute have been studied towards this objective and retrofitting details are being worked out.

However there is another equally important issue to be addressed. Even under smaller intensity earthquakes in which the buildings will not be affected, the non-structural building components and particularly the furnishings and equipments in the hospital can be badly shaken as a result of which they can overturn or slide crashing down on the floor and hitting people to cause injuries. The hospital can thus become non-functional. The Olive View hospital in California got destroyed during San Fernando earthquake of 1971 and was reconstructed with stronger specifications. During the Northridge earthquake of 1994 this hospital building was not damaged but there was so much non-structural damage to the contents, particularly to hospital equipments, that it became non-functional when it was needed the most.

Delhi can have a large earthquake with magnitude 6.7 or MSK intensity VIII but at large intervals of time, whereas smaller earthquake causing MSK intensity VI – VII can occur more frequently which may not be able to cause structural damage but can impact the hospital contents adversely stopping the functioning of hospital as well as causing large scale economic loss since the hospital contents may even account for 80% – 90% of the total hospital cost. The objective of this guide is to indicate how the non-structural hazards can be quickly estimated by the hospital staff and how the same can be prevented at very small cost.

The Guide is being issued as the first draft. Comments and suggestions of the readers are solicited to improve it, so as to make it adequately useful for safety in hospitals.

## **Acknowledgement**

The assistance provided by Sh. Ankush Agarwal, Technical Officer, UNDP in preparation of this guide is gratefully acknowledged

**Anand S. Arya**  
**National Seismic Advisor**  
**GoI-UNDP, DRM Programme**

**14<sup>th</sup> February, 2007**

# Contents

1.	Introduction	...	1 – 2
2.	Structural & Non-structural Elements	...	2
3.	What Happens During an Earthquake?	...	2 – 3
4.	The Earthquake Risk in Delhi/NCR	...	3 – 4
5.	Reducing “Non-structural” Hazards in Hospital	...	4 – 5
6.	Non-structural Mitigation – A Few Simple Steps	...	5
7.	Step One:- Understanding earthquakes & safety requirements	...	5 – 6
8.	Step Two:- Earthquake hazard identification in hospital	...	7 – 10
9.	Step Three:- Reducing non-structural hazard	...	10 – 12
10.	Step Four:- Hazard survey & prioritization	...	12 – 15
11.	Implementation of Priorities	...	15 – 16
12.	References	...	17

## 1. INTRODUCTION

Experience in damaging intensity of earthquakes has shown that buildings are destroyed or damaged to various extents. Also their contents are badly shaken and they fall down by toppling over, or by rolling if resting on rollers or wheels, or by sliding on their supports and crashing down on the floor. Many times such objects injure or even kill the inmates by cutting, piercing or hammering effects. In most cases the functioning of the building as a hospital or library or a shopping centre or an industry gets adversely impacted.

A building may remain standing after an earthquake, but it might be functionless due to nonstructural damage to the equipment, lifeline conduits and other non-structural elements like partition walls, veneers, ceilings, window panes etc. Assessment of non-structural vulnerability is to be made in order to estimate the expected damage that these elements may suffer when subjected to earthquake shaking at different levels of intensity and the consequence to the functionality of the hospital. The cost of the non-structural elements in a building may even be much higher than that of the structure. Particularly in hospitals, it may reach upto 80 - 90% of the total facility value. Moreover, the susceptibility to non-structural damage could be high even in a moderate level earthquake (MMI VI-VII). This can affect or destroy vital aspects of a hospital including those directly related to its function, without significantly affecting the structural components. Thus, in an earthquake, the external appearance of a hospital might be unaffected, but it may not be able to care for patients if the internal facilities have been damaged.

The desired level of performance of hospital facilities is much higher than that of other utility services because it is imperative that hospitals remain fully functional after an earthquake. In the case of large number of injuries expected, demand for medical services will be very high within the first 24 hours. In summary, a non-structural vulnerability assessment and consequent implementation of mitigation measures in hospitals will be justified on the following grounds:

1. Hospital facilities must remain as intact as possible after an earthquake due to their role in providing routine medical services as well as attending to the possible increase in demand for medical treatment following an earthquake.
2. In contrast to other types of buildings, hospitals accommodate a large number of patients who, due to their disabilities, are unable to evacuate a building in the event of an earthquake.
3. Hospitals have a complex network of electrical, mechanical and sanitary facilities as well as a significant amount of costly equipment all of which are essential both for the routine operation of the hospital and for emergency care. Failure of these installations due to a seismic event cannot be tolerated in hospitals as this could result in its functional collapse.

4. The ratio of the cost of nonstructural elements to the total cost of the building is much higher in hospitals than in other buildings. In fact, while nonstructural elements represent approximately 60% of the value in housing and office buildings, in hospitals these values range from 80% to 90%, mainly due to the cost of medical equipment and specialized facilities.

## **2. STRUCTURAL & NON-STRUCTURAL ELEMENTS**

The “structure” is the part of the building that is designed to carry the weight of the building (dead load), its contents and people (live load), and the impact of wind and ground-shaking (dynamic load). The “structural elements” differ in each type of building, but generally they include the foundation, columns, slabs, beams, and “load-bearing” walls. The biggest danger is from those buildings that have not been designed, constructed, or maintained to withstand expected earthquake shaking.

The non-structural building elements include the stairways, doors, windows, chimney, lighting fixtures, heating ducts and pipes, wall cladding, and false ceilings. The “building contents” includes all of those items that users bring into a building; furniture, appliances, electronics, equipment, coolers and air-conditioners, stored items, and so forth. When a building is totally damaged and collapsed, everything in the building is crushed and lost. But some of the deaths, many or most of the injuries, a large proportion of economic damage, destruction and disruption associated with earthquakes are caused by “non-structural” building elements and building contents that break, fall or slide.

In a large scale disaster, medical response resources are found insufficient to meet the immediate needs. Minor injuries occurring due to non-structural elements can take scarce medical resources away from people with life-threatening injuries. Thus moderate injuries that are normally easily handled can become life threatening. For this reason it is very important for us to do the small things that can prevent even the small injuries. Many “non-structural” hazards are easily and inexpensively avoided. People in many different countries have found new and simple ways to reduce these risks. Working together, we hope to make our communities safer from earthquake hazards.

## **3. WHAT HAPPENS DURING AN EARTHQUAKE?**

The Theory of Plate Tectonics tells us that earthquakes are caused by the release of energy when the large plates that float on the earth’s surface suddenly slip past each other. The energy released creates seismic waves that shake the ground as they pass through. The ground motion comes in the form of different types of waves. The waves vary in their vibration characteristics and affect the objects and structures differently.

As earthquake waves are generated, unsecured objects are set into motion and slide, topple or collide. This is very similar to a passenger riding in a car without a seatbelt. If the brakes are applied suddenly the people inside can go flying. Heavy and large objects that can seriously injure people or block exits must be secured to prevent this kind of damage in an earthquake. The solution is to secure the objects to the floors or walls or the columns of the building so that they move back and forth together without damage.

#### **4. THE EARTHQUAKE RISK IN DELHI/NCR**

The city of Delhi lies approximately 250 kilometers from the Himalayas, the world's tallest mountain range. The Himalayas are still being built up by the collision of the Indian tectonic plate with the Eurasian tectonic plate, and for this reason are prone to frequent earthquakes. The colliding plates flex, storing energy like a spring, and when the plate's margin finally slips energy is released and an earthquake results.

Shaking from large Himalayan earthquakes, which can be greater than Magnitude 8, can cause damage in Delhi. The tectonic collision also causes the Indian plate to buckle, resulting in earthquakes away from the plate boundary. Five earthquakes of Magnitude 5.5 to 6.7 are known to have occurred in or close to Delhi since 1720 AD. Two major fault lines, the Delhi-Haridwar ridge and Delhi-Moradabad pass through the territory. Both faults have the potential to generate earthquakes of Intensity VIII on the MSK scale. Roughly, earthquakes of M 5.0 to 5.9 may produce maximum MSK intensity VI to VII and M 6.0 to 6.7 may create maximum MSK intensity VII to VIII. The effects observed in these Intensities are as follows:

##### **MSK VI: - Frightening**

- a) Felt by most indoors and outdoors. Many people in buildings are frightened and run outdoors. A few persons lose their balance. Domestic animals run out of their stalls. In few instances dishes and glassware may break, books fall down. Heavy furniture may possibly move and small steeple bells may ring.
- b) Slight damage (Grade 1) is sustained in 5% of ordinary brick buildings.

##### **MSK VII: - Damage of Buildings**

- a) Most people are frightened and run outdoors. Many find it difficult to stand. The vibration is noticed by persons driving motor cars. Large bells ring.
- b) In 50% buildings of reinforced concrete slight damage (Grade 1) is caused; in 50% of ordinary brick buildings moderate damage (Grade 2). Infill walls of half brick thick in cement mortar 1:6 may fail in out of plane.

### **MSK VIII: - Destruction of Buildings**

- a) Fright and panic; also persons driving motor cars are disturbed. Here and there branches of trees break off. Even heavy furniture moves and partly overturns. Hanging lamps are damaged in part.
- b) 75% buildings of reinforced concrete suffer moderate damage (Grade 2) and 5% of heavy damage (Grade 3), 75% ordinary brick buildings suffer heavy damage (Grade 3). Occasionally breaking of pipe seams. Memorials and monuments move and twist. Tombstones overturn. Stone wall collapse. Infill walls of half brick thick in cement mortar 1:6 will fall out of plane unless laterally supported.

It is therefore seen that whereas strong shaking can cause moderate to heavy damage to life and property in Delhi, even moderate shaking of intensity VI can cause substantial non-structural damage. For these reasons it is important to take measures for reducing the impact of future earthquakes on our hospital facilities.

To reduce the risk to the life and limb of the communities, we must ensure that

1. The hospital building remains safe against collapse or heavy damage.
2. The functioning of the hospital facilities continues with only minimum interruption.

While the building safety from probable maximum earthquake will require special studies by competent structural engineers, the functionality of the medical services could be ensured by the hospital management, its staff and maintenance engineers, by safeguarding non-structural damages to the contents and the equipments in the hospital.

### **5. REDUCING “NON-STRUCTURAL” HAZARDS IN HOSPITALS**

Past experiences shows that during an earthquake, building contents, and parts of the building that are not fixed are severely shaken. Serious dangers are caused by falling, sliding and crashing objects that can crush, pierce and cut or spill dangerous chemicals.

The purpose of this note is to introduce the importance of securing the contents of hospital buildings, so that in an earthquake the furnishings and other objects do not *overturn* or *slide*. These “*non-structural* risk reduction” measures will do four important things:

1. Prevent deaths and injuries to doctors, nurses, patients, visitors and staff
2. Protect hospital equipment and other materials
3. Increase the community’s ability to keep the hospital open for use in the emergency.

4. Enable the hospital management to continue its services with minimum disruption.

## 6. NON-STRUCTURAL MITIGATION - A FEW SIMPLE STEPS

Disaster risk reduction can be achieved through a series of small steps. *Everyone* needs to play his role in reducing the dangers of natural and man-made hazards. We already have the knowledge, we only need to create a culture of safety. Decisions and steps taken by individuals and families at home, by workers and students in schools and offices, by doctors and workers in the hospitals, by citizens in their neighborhoods, and by politicians, government agency workers and professionals are all important. Here it is intended to show to the hospital management the actions to be taken by the doctors and the staff and some of the things they can do that will make a real improvement towards safety in the hospital during earthquakes.

Non-structural mitigation in hospitals can be accomplished in a few simple steps:

- 1) Sensitization (understanding earthquakes and safety requirements)
- 2) Earthquake Hazard Identification in the hospital
- 3) Hazard survey and prioritization.
- 4) Reducing non-structural hazards

## 7. STEP ONE: Understanding earthquakes and safety requirements

The first step is awareness and sensitization about earthquakes. This includes learning what earthquakes are and what happens during an earthquake, knowing the earthquake and other kinds of risks in the area, and recognizing the “structural” and “non-structural” dangers in hospitals. Keeping all the risks in mind, one may need to think creatively about how to balance different needs with safety.

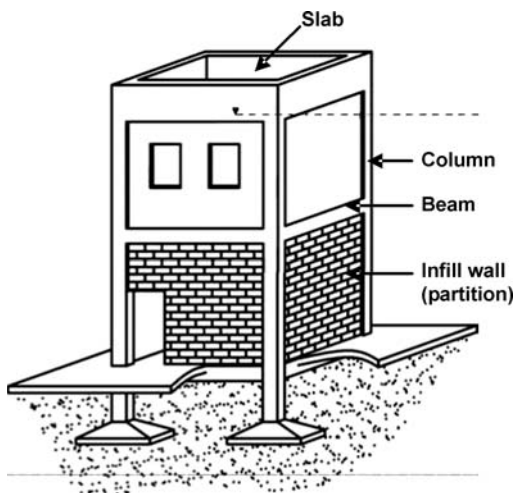

### What is “structural element”?

The “**structural elements**” of a building carry the weight of the building itself, the people and things inside, and the forces of nature. These “load-bearing” elements include the frame (columns, slabs, beams) and the walls in masonry and adobe construction.



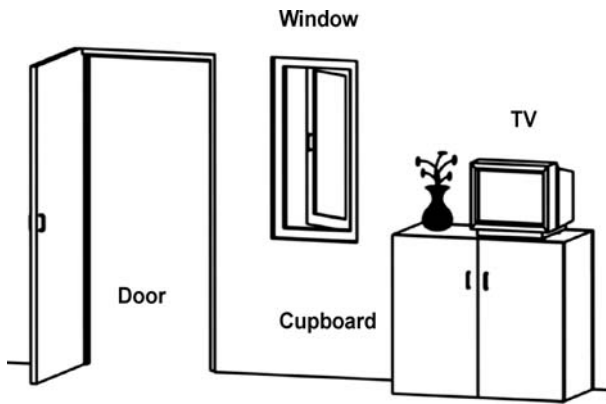

### What is “non-structural”?

The “**non-structural elements**” of a building do not carry the weight of the building, and include windows, doors, chimney, stairs, infill partition walls, pipes and ducts. They include “building contents” that users bring with them: furniture, coolers, water tanks, etc. and very importantly the various types of hospital equipment.

The non-structural components to be considered in the vulnerability assessment are listed below in Table 1.

**Table 1. Non-structural elements to be considered in the vulnerability assessment**

<b>Architectural</b>	<b>Equipments &amp; Furnishings</b>	<b>Basic Installations and Services</b>
• Divisions and partitions	• Medical equipment	• Medical gases
• Interiors	• Industrial equipment	• Industrial fuel
• Facades	• Office Equipment	• Electricity
• False Ceilings	• Furnishings	• Telecommunications
• Covering elements	• Supplies	• Vaccum network
• Cornices	• Clinical Files	• Drinking water
• Terraces	• Pharmacy shelving	• Industrial water
• Chimneys		• Air conditioning
• Surfacing		• Steam
• Glass		• Piping
• Attachments (Signs, etc.)		• Waste disposal
• Ceilings		
• Antennas		

It is important to remember that in reinforced concrete frame buildings, the cladding as well as partition walls will be in the nature of in-fill panels and may not be stable. These will need stabilization with the help of a qualified structural engineer. Heavy furnishings may then be fastened to such infill panels walls; otherwise they should better be fastened to the frames.

## 8. STEP 2:- Earthquake Hazard Identification in the Hospital

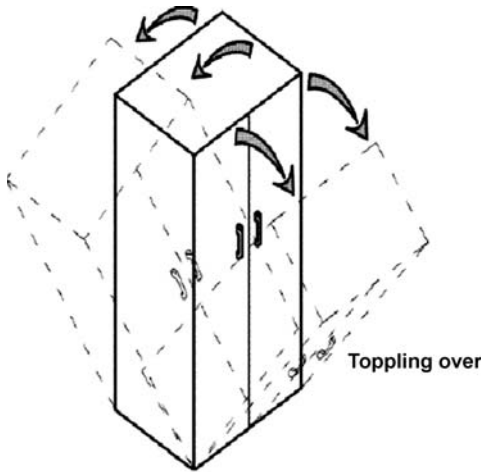

### Tall or narrow furniture can fall!

Objects that are taller than their width or depth can easily topple forwards, backwards or sideways. Objects that are much heavier on the top than on the bottom can easily topple in all directions.

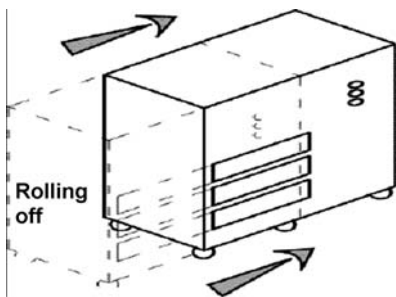

### Items on wheels or smooth surfaces can roll or slide!

Objects on wheels can roll, or on slippery surfaces can slide. Objects that are much heavier on the bottom than on the top can also slide, but not overturn.



*Roller mounted equipment without restraint*



*Unanchored computers on roller supported table.*

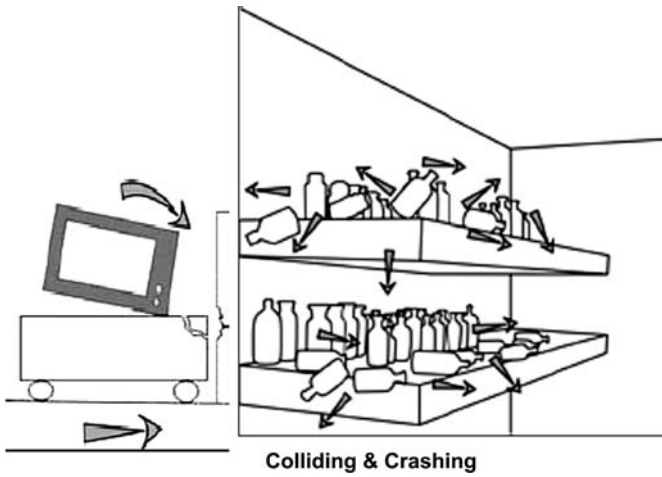

**Large or small things can knock into each other!**

Objects can bang and collide with each other. Small objects can fall, and cause dangerous breakages and spills.

**Hanging objects can fall!**

Heavy objects that are hung on walls or from the ceiling can fall. Cabinet doors can swing open and shelf contents can tumble out

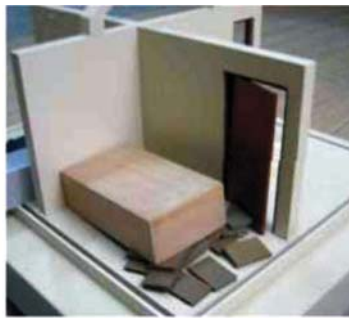

Blocking exit

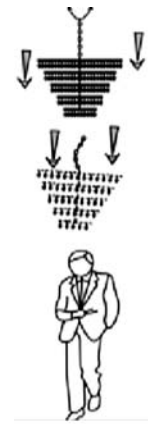

Falling Down

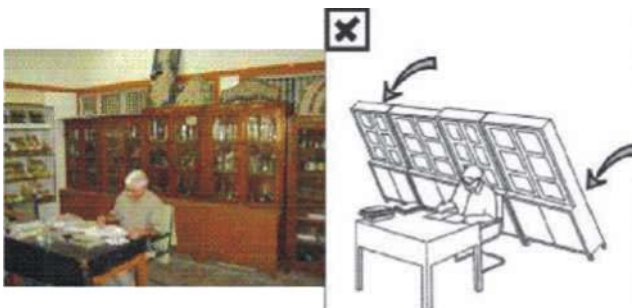

In an earthquake, items inside the building can fall harming people and blocking exits



*Shelves containing medicines etc. without anchorage*

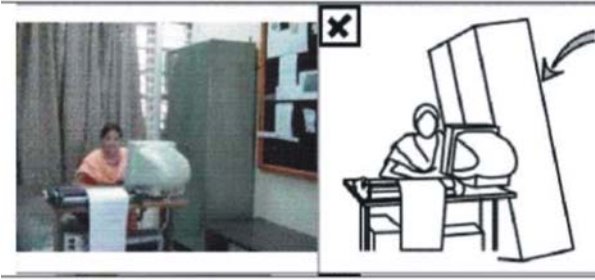

**Storage cabinets next to sitting space without anchorage**

**Unanchored storage cabinets in the corridor can cause obstruction during evacuation.**

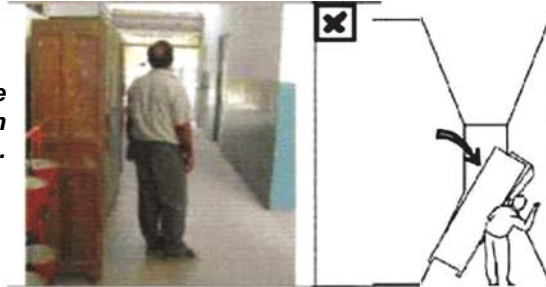

**Unanchored furniture and accessories**



**Picture frames resting on furniture fall down**

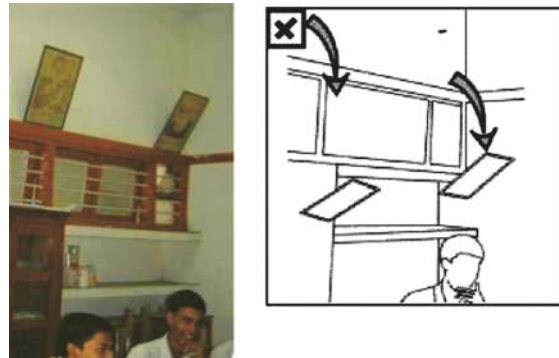

**Syntex Water tank at roof without anchorage**



**False ceiling at corridor**





**Pipes crossing an expansion joint on buildings:  
no flexible connection.**



**Unanchored oxygen cylinders**

## 9. STEP 3:- Reducing Non-Structural Hazard

There are three important ways for reducing the risk from non-structural hazards

- A. To relocate furnishings and contents
- B. To secure Non-Structural Building Elements
- C. To secure the furnishings and equipments to walls, columns or floors.

For B & C consultation with engineers and technicians may be sought.

### A. To relocate Furnishing & Contents

Heavy furniture should be kept away from the places where people sit (or sleep). If items cannot be secured to a sound structural member they may need to be moved to a place where they will not cause a hazard. Corridors and exist routes should be kept free of obstructions. Large occupancy rooms should have two exist doors.

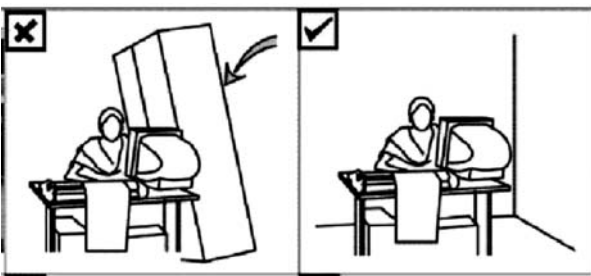

### Clear Corridors, Doorways & Exit Paths:-

Relocate or re-position items that cannot be secured, so that they do not block exit corridors

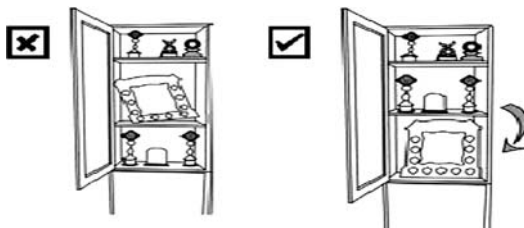

### Move Furnishings:-

The simplest way to reduce risk is to move some furniture items so they will not hit anyone or block exits

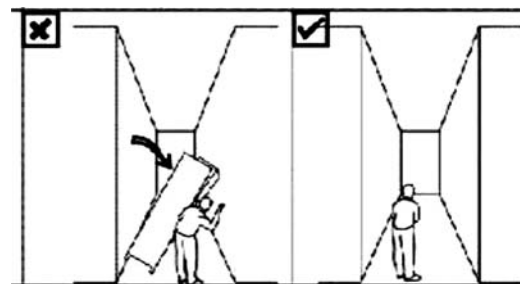

### Place Heavy Items Down Low:-

Heavy and breakable items that cannot be secured should be kept at lower level. Lighter objects can be placed higher up

## B. To secure the Non-Structural Building Elements

The most important but hazardous element is the brick infill partition wall which can topple over laterally or badly crack longitudinally. One way to stabilize such walls will be to provide vertical steel angles 50 X 50 X 6 mm on its both faces vertically and attached to the wall through bolts. The ends of the angles should be fixed in the floors below and above. The angles may be spaced not further than 1.5 m apart. The angles will not only provide the requisite stability to the wall but may also be used for fixing the equipment and the furnishings.

## C. To secure the Furnishings and Equipments

Most of this can be done with easily available supplies and simple methods. Secure objects to the structure of the building, so that they shake *with* the building. Some objects can be secured to a table or counter top.

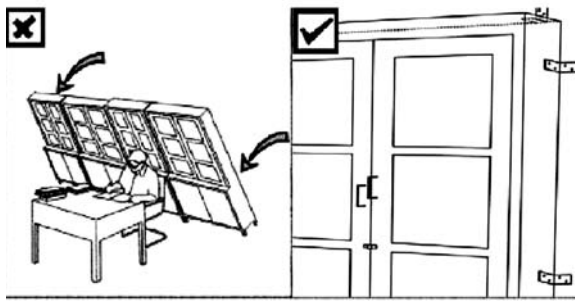

*Fasten Tall and Heavy Furnishings:-*

Use “L – Brackets” or finely woven nylon strapping to secure furniture to wall

### *Secure Picture Frames and Hanging Objects:-*

To avoid injury from broken glass and falling objects is to use a hook that is almost closed, or tie picture frames and similar items to a hook in the wall.

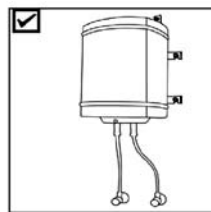
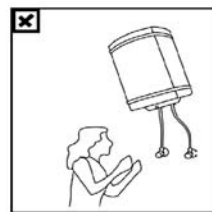
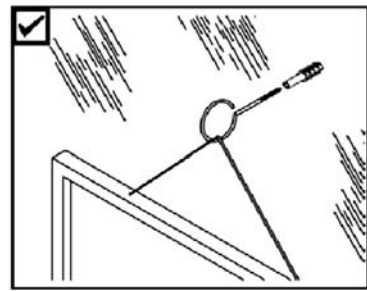
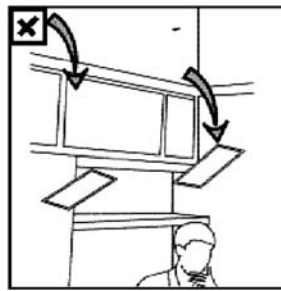

*Secure Wall–Mounted Items, Shelf Contents and Hazardous materials:-*

Each item should be considered separately for the simplest solution

### *Secure Objects That Can Slide:-*

Short squat items with wheels or placed on slippery surfaces can be chained to a hook on the wall, if their height/width ratio is 3/2 or more, the items may need to be secured with straps.

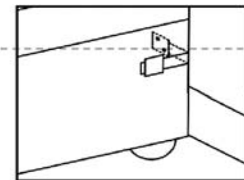
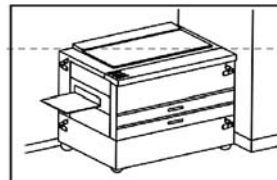

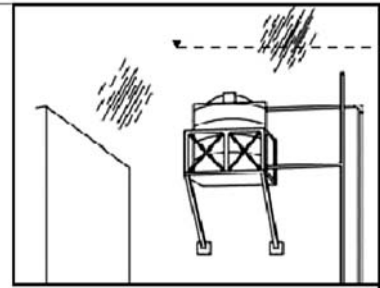

### *SECURE WATER TANKS*

Water tanks should be secured from all sides so that they cannot topple. There must be enough vertical support and strapping so that that the tank will not jump up out of its seat, during the vertical and lateral motion of an earthquake. Stabilizing wires must be secured to concrete rooftop, or beams, not to parapet.

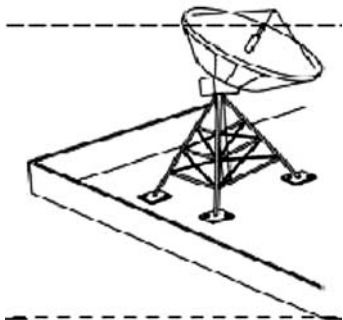

*Secure Signage, Satellite Dishes, Architectural Cladding an Glass*

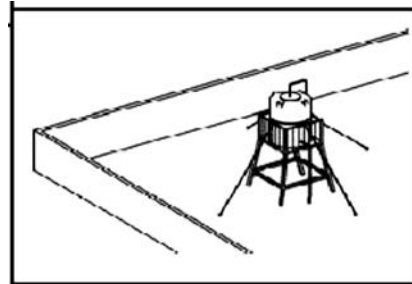

## **10. STEP 4:- Hazard Survey and Prioritization**

Now there is a need to identify all of the non-structural hazards in a systematic way, and to prioritize for taking action immediately or later on in due course. This has to be done room by room, to identify those things that could be dangerous in case of an earthquake by fall from above, by sliding or breaking when the earth shakes.

A sample survey planning form is shown in Table 2 and an example of list of evaluated equipment in hospital is given in Table 3 for ready reference. This form is provided to record all of the details, and to guide the mitigation work. It is to be considered whether an item poses a threat to life, could cause injury, would disrupt business continuity, cause economic hardship if lost, or would cause loss of cultural or historical heritage and to decide how you would tackle each item. Based on what is perceived, it has to be decided in each case whether the item is of “high”, “medium” or “low” priority.

It is important to survey in each and every room and corridor of the building. One should not forget the kitchen, the library, and the labs where some of the most hazardous items can be found. This is a good activity to be undertaken by the hospital administrative committee or a safety committee or a disaster preparedness committee as the hospital administration may decide. The Hazard survey committee should include administrators, doctors, staff, and community members. As the risks are identified, it will be useful to consult with all the users of the room or area in order to understand the simplest solutions to make the environment safer - and the solutions that everyone can live with. This is the best way to be sure that the mitigation efforts will be maintained.

The Earthquake Hazard survey can also be carried out as an activity involving the medical students which will serve to sensitize them about the non-structural hazards.

### **How to Use the Non-Structural Hazards Survey and Planning Form**

The form is very simple to use. Make a copy of one form for each room or area of the building. You will also need one form for the perimeter of the school, outside the buildings.

As you identify each item that needs fastening, write them in the boxes in the left hand columns. Similar items can be grouped together, especially if the fastening solutions are the same. As you identify the hazardous items in the room, discuss the different solutions that can be used to stabilize the item, and select the safest and lowest cost method. In some cases aesthetic considerations may be important, so consider making these measures look nice too. Sometimes you may want the fastening method to be seen and be obvious, other times you may want to hide it as much as possible.

**Item:** In the first column write the name of the hazardous item.

**Risk Type:** For each item, depending on its characteristics and location, identify what type or types of risk it poses. If it can cause death, serious injury, or even moderate injury, check the box that says “Life Safety”. This includes items that could explode or cause a release of hazardous materials, or rupture of gas lines, and fire hazards. If the item can be damaged or destroyed and would represent a significant cost to replace, check the “Economic Value” box. You may even want to write in this box the estimated cost, which will help you identify the cost benefits of mitigation. If the item is vital to continue operation of hospital functions, then check the “Operational Continuity” box.

**Priority:** Every item posing life safety item should be deemed a *High* priority. Suppose that you do not have enough funds to take care of everything at one time. You will want to do the work in 3 phases. Keeping in mind the type of risk posed decide whether each item is a High, Medium, or Low priority.

**Device:** A list of many device types is shown in the Device Types Legend on the sample form. When you have learned the options you will be able to note in these columns the type, size and number of devices needed to secure this item.

**Engineering:** If the item is very large or heavy, you will need engineering consultation to decide how to best secure it. Put a check mark in this box if you need engineering help with this item.

**Notes:** Make any other notes here to help plan your mitigation measures.



**Table 2.**  
**SAMPLE**  
**NON-STRUCTURAL HAZARDS SURVEY AND PLANNING FORM**

Room or Area Description: Staff Room  
 Users consulted: Staff at lunch time

Item & description	Risk Type (check all that apply)		Priority	Devices (see choices in legend)			Notes
	Life Safety	Economic Value (cost to replace)		Operational Continuity	Device Type	Size	
One computer		✓					
1 METAL cabinet	✓		M	2			
2mx1m			H	1	L	6	
				2		12	
				3		12	
				4		12	
2 metal cabinets			L	1	L	8	easy to do all at same time
2mx1m				2+3		16	
				4		16	
4 fans	✓		H	11	5 cm x 1 m	2 wood strips	
Water tank	✓		H	6, 7	?	4, 8	✓
				1, 7	?		✓

**Device Types Legend**

- 1 L Bracket
- 2 Screws
- 3 Anchors
- 4 Nuts and bolts
- 5 Flat metal connector
- 6 Hook (describe)
- 7 Chain
- 8 Shelf Restraint (describe)
- 9 Strap (and Buckle or Clips)
- 10 Museum Wax
- 11 Padding (describe)
- 12 Window Covering or film
- 13 Acrylic mount / mono filament
- 14 Mechanical Latch
- 15 Magnetic Latch
- 16 Shelf Mat
- 17 Door opening outwards
- 18 Fire Suppression Equipment
- 19 Emergency lighting
- 20 Other (describe)

**Table 3.** Example of a list of evaluated equipment

<b>Type of equipment</b>	<b>Location</b>	<b>Size</b>	<b>Vulnerability (V)</b>	<b>Consequences (C)</b>	<b>Priority</b>	
<i>Component</i>	<i>System or service</i>	<i>Characteristics</i>	<i>(H,M,L)</i>	<i>(H,M,L)</i>	<i>f(V,C)</i>	<i>Type of support</i>
Oxygen tank	Oxygen network	5.5 x 2.3	H	H	1	Legs w/ bolts
Transformer	Power network	3 x 2.5 x 2	H	H	1	Bolts
Circuit boards	Power network	6 x 2 x 1	H	H	1	Simple brace
Anesthesia machine with monitor	Operating theaters	1 x 2 x 2.2	H	H	1	
Water tanks	Drinking water supply		M	H	2	
Gas connection	Gas supply		M	H	2	Without anchors
Emergency generator	Power network		M	H	2	Bolts
Miscellaneous equipment	Clinical laboratory	Various	L	H	3	Tabletop equipment
Telephone switchboard	Communications	5x1.4	H	M	4	Simple brace
Shelves	Sterilization center	Various	H	M	4	Without anchors
Freezer	Blood bank	2.5 x 2 x 0.5	H	M	4	Simple brace
Oxygen cylinders	Operating theaters	Various	H	M	4	
Elevator engine	Elevators		M	M	5	Bolts
Elevator controls	Elevators	2.5 x 1	M	M	5	Bolts
Elevator pulleys	Elevators		M	M	5	Bolts
Dialysis unit	Hemodialysis	0.8 x 1.2	M	M	5	Simple brace w/ rollers
Lamp	Plastic surgery	Various	M	M	5	Built in
Incubator	Neonatology	Various	M	M	5	Simple brace w/rollers

## 11. IMPLEMENTATION OF PRIORITIES

Non-structural risk reduction is something that is unique to each and every hospital. There are some very important partners in achieving nonstructural risk reduction. All should understand and have a sense of ownership for non-structural risk reduction, doctors and staff should be involved. The more people who understand this work, the better will be the maintenance and ongoing continuation of this effort. This will include:

- Hospital Director/Dy. Director
- Public Works Department personnel assigned to the hospital
- Local Fire Department Personnel
- Hospital welfare committee
- Staff
- Medical Students

Implementation of non-structural mitigation plan requires a modest investment of time and money. Considering that death, injuries and significant economic losses are caused by non-structural elements, the investment is well worth making. When resources are scarce, you can use the priorities you have set, High, Medium and Low, to stagger the project into two or three steps. Often it is easy to do many small lower priority items at the same time as tackling the most important ones.

In hospitals, the safety of patients, doctors and nursing staff are of highest importance. Anything that can harm them or block safe evacuation should be given top priority. For example, exits and corridors should be kept clear of all obstacles, so that large numbers of persons can move out of the building safely in the shortest possible time. There may be some items that are more difficult or costly to secure that are also important to safety and survival - for example water tanks, which will be needed for their contents. For these items you will need the help of a qualified engineer.

In a potential mass casualty situation, there is a greater need to reduce moderate or minor injuries. Hazard prone areas like chemistry labs or electrical warehouses should be secured as these areas can have a multiplier effect leading to fire and hazardous material release and thereby greatly increasing the number of casualties. Any other designated area, which would serve as a control room during emergencies should also be secured. These areas ensure operational continuity in times of emergency.

Ultimately, the final decision on what would be the best way to implement the non-structural mitigation plan lies with the hospital management. The design and layout of the building, availability of open spaces, and strength of the hospital etc are important factors that determine the priorities for implementation.

## **References**

1. Non-structural Risk reduction Handbook for Schools, Delhi Disaster Management Authority & Geo-Hazards International.
2. Survey of Non-structural Components at Guru Teg Bahadur Hospital, Delhi, July 2005 by S.Choudhury, A. Solomon, Y.Singh & D.K.Paul, Department of Earthquake Engineering, IIT Roorkee
3. Guideline for seismic Vulnerability Assessment of Hospitals, EPR Publication, Nepal
4. Principles of Disaster Mitigation in Health Facilities, Chapter -3, Non-structural Vulnerability.

---

---

*Prepared by:*

**Professor Anand S. Arya**

*Assisted by:*

**Ankush Agarwal**

under the **GoI-UNDP Disaster Risk Management Programme**

Email: [anand.s.arya@undp.org](mailto:anand.s.arya@undp.org), [ankush.agarwal@undp.org](mailto:ankush.agarwal@undp.org)

**NATIONAL DISASTER MANAGEMENT DIVISION**

Ministry of Home Affairs, North Block, New Delhi

Tel: 91-11-23093178; Tele/fax: 23094019

Email: [ndmindia@nic.in](mailto:ndmindia@nic.in); Website: [www.ndmindia.nic.in](http://www.ndmindia.nic.in)