

# **“Child Friendly Schools Infrastructure Standards and Guidelines”**

## **Primary and Tronc Commun schools**



**Rwanda Ministry of Education**

**Approved document  
August 2009**



## Acknowledgements;

**Lead Coordination;** Eudes Kayumba / Diogene Mulindahabi MINEDUC Director of Schools Construction

**Lead Partner;** Luca Ginoulhiac UNICEF Construction specialist

**Lead Author;** Seki Hirano Schools Infrastructure consultant

The Ministry of Education Rwanda would like to thank the following individuals and organisations in setting these National Standards and guidelines.

**Contribution to the text;** Joseph Ashmore, Henri Esseqqat, Annika Grafweg, Warren Habimana, Martin Jäger, Guy Mbayo Kakumbi, Evariste Karangwa, Rowland Keable, Ayih Kougbeadjo, Tulio Mateo, Jean de Dieu Ntamugabumwe, Charles Nabongo, Dr. Ntagwirumugara Etienne, Maniza Ntekim, Patrick Suubi, Lies Vandenbossche, Toshikazu Mito,

**Expert inputs from;** Jean Batist Bizimana, Kamana Yisa Claver, Charles Gahima, Nathalie Gahunga, Issa Ibrahim, Innocent Kalinno, Viviane Mukanyirigira, Alexis Munyaneza, Galllcan Mugabonake, Narcisse Musabeyezu, Janet Nakato, Alexandre Ndahumba, Fidele Nteziyaremye, Richard Nyoukuru, Eva Paul, Ahmad Parsa, Daisuke Sagiya, Rosette Uwizeyimana, Oliva Umuteteri, Iris Uyttersprot, Uwitonze Francis Xavier.

## Support from the following agencies;

MINEDUC, MININFRA, UNICEF, UNDP, BCT, ADRA, CARE, CITT, KIST, KIE, DIFID, JICA, Electro-gas, Handicap International, Rheinland-Pfalz Rwanda, , Right to play.

**Regional and national verification and feedback** 5 regional and one national consultation was carried out where representatives such as district directors of education, district infrastructure officers, teachers and head teachers of public and private schools from all district were invited to verify the document and add comments. Numbers of participants were represented and feed back from these consultation incorporated into this document.

## Abbreviations & Acronyms

AIDS	Acquired Immuno Deficiency Syndrome
BAD/ADB	African Development Bank
BCT/BTC	Belgium Technical Cooperation
CEB	Compressed Earth Blocks
CFS	Child friendly School
CREP	Construction la rehabilitation et l'equipment d'ecoles primaires
HIV	Human Immunodeficiency Virus
ICT	Information Communication Technology
INEE	Inter-Agency Network for Education in Emergency
KIST	Kigali Institute of Science and Technology
MINEDUC	Ministry of Education
MININFRA	Ministry of Infrastructure
NER	Net Enrollment Rate
NGO	Non-Governmental Organisation
PTC	Parents and Teachers Committee
SEN	Special Education Needs
WHO	World Health Organization
UNESCO	United Nations Education now, Scientific and Cultural Organization
UNICEF	United Nations Children's Fund

## CONTENTS

### Primary and Tronc Commun schools .....1

Abbreviations & Acronyms	2
--------------------------	---

### Section 1 – Standards Framework.....4

1.1 Introduction	4
1.2 Targeted use and audience	4
1.3 Rwanda Education Quality Standards 2008	4

#### Four standards of Child Friendly Schools Infrastructure

1.4 Rwanda specific standards	5
1.5 Child Friendly Schools Approach	5

### Section 2 – Planning .....6

2.1 Categorization grading of facilities	6
2.2 Schools Infrastructure check list	6
2.3 Refurbishment / Upgrading	8
2.4 Urban / Rural	8
2.5 New site selection	8
2.6 Site layout for schools (Refer to site zoning plan below.)	9
2.7 Atmosphere of the school	10
2.8 Disaster Risk Reduction Strategy	10
2.9 Energy	10
A.2.7 Electricity	12
2.10 Appropriate construction technology and material	12
2.11 Community involvement	14
2.12 Curriculum -9 year's basic education	14

### Section 3 - Standards – guidelines.....15

#### Standard A .....15

##### “A school must have appropriate, sufficient and secure buildings.”

A.1 Schedule of accommodation	15
A.1.1 Class rooms / Basic teaching areas	15
A.1.2 Head teachers room	16
A.1.3 Staff room / teachers resource room	16
A.1.4 Storage space	16
A.1.5 Science Laboratory	16
A.1.6 ICT room	17
A.1.7 Play/ Games /leisure area	18
A.1.8 Outdoor learning area / Habitat area	19
A.1.9 Library / Learning resource area	19
A.1.10 Multi purpose hall	19
A.1.11 Medical sick room	19
A.1.12 Kitchen	19
A.2 Spatial qualities	19
A.2.1 Internal temperature	19
A.2.2 Ventilation	19
A.2.3 Day Lighting	20
A.2.4 Acoustic	20
A.2.5 Water penetration	20
A.2.6 Dust	20
A.3 Safe and Secure buildings	20
A.3.1 Security	21

#### Standard B .....22

“A school must be a healthy, clean, secure and learner protecting environment.”	22
Healthy and clean environment	22
B.1 Water	22
B.1.1 Potable water (safe drinking water)	22
B.1.2 Non potable water	22
B.1.3 Water supply systems	22
B.1.4 Testing water supply systems and the quality of water delivered to children	23
B.2 Sanitation Facilities (Toilet and hygiene)	23
B.2.1 Sanitation Facilities Quantity	23
B.2.2 Sanitation Facilities Quality	24
B.2.3 Sanitation Facilities Usage	24
B.2.4 Technical solutions	24
B.3 Environmental and Waste management	24
B.3.1 Composting	25
B.3.2 Incinerator	25
B.3.3 Stagnant water	25
B.4 Secure and learner protecting environment	26
B.4.1 Passive surveillance against harassment and abuse	26
B.4.2 Fences	26

#### Standard C .....27

##### “A school must have a child-friendly, barrier free environment which promotes inclusive access and equal rights of every child.”

27	
C.1 Child-Friendly environment	27
C.2 Barrier Free environment	27
C.2.1 Access	27
C.2.2 Ramps	28
C.2.3 Accessible toilets and hygiene facilities	28
C.2.4 Classrooms	29
C.2.5 Signage	29
C.2.6 Tactile surfaces	29
C.2.7 Special Needs Rooms	29
C.3 Equal access	29
C.3.2 Specific Religious needs	30
C.3.3 Gender Balance	30

#### Standard D .....31

##### “A school must have adequate and appropriate equipment that support the level of education.”

D.1 Furniture	31
D.1.1 Class room furniture design	32
D.1.2 Class room layout	33
D.2 Equipment list	35

#### Bibliography .....36

#### Annex

Sample design drawings

## Section 1 – Standards Framework

### 1.1 Introduction

This document outlines the infrastructure standards which are expected to be met by all Primary and Tronc Commun schools in the Republic of Rwanda. Through this document the Ministry of Education of Rwanda sets clear the levels of acceptability as a standard and gives practical guidance on how to achieve them. These standards have been developed through a comprehensive consultation process with the school communities including head teachers, staff members and pupils. Then these concerns were further developed through technical expert review process where many specialists from organizations have contributed. (Refer page 3). The draft was then presented at regional and national consultation meeting where directors of education, head teachers and teachers from public and private schools gathered to give their inputs. It is with all these inputs that a Rwanda specific standard and guidelines were able to be drafted.

As Rwanda continues to develop at a rapid rate, it is acknowledged that increasing the quality of schools is an ongoing process. Thus through this document the Ministry of Education states the minimum standards, as a **Must** and simultaneously offers best practice guidelines through the use of terminologies such as **Should** and **May**. Terminology definitions;

<b>Must</b>	States the minimum requirement of accommodation and its quality.
<b>Should</b>	Gives guidance on spaces and quality that is encouraged which is in line with best practice.
<b>May</b>	Gives good practice guidance on spaces and qualities identified as beneficial if resources are available.

The Ministry of Infrastructure has launched<sup>1</sup> the “Rwanda Building Control Regulations.” These regulations will take precedent over resolving construction quality and procedural issues, as the scope of this document offers schools specific infrastructure guidelines.

### 1.2 Targeted use and audience

These standards and guidelines have been written to harmonise our understanding of what an acceptable school infrastructure is. The targeted groups include; Ministry staff, District staff, International agencies, NGOs, Faith Based Organisations, School community, PTC, Private sector, building professionals and contractors. This document is to be referenced by all who are involved in the planning, monitoring, designing, procuring, constructing and rehabilitating school infrastructures.

### 1.3 Rwanda Education Quality Standards 2008

“*The Rwanda Education Quality Standards 2008*” issued by MINEDUC sets out the quality standards in promoting improvements to education. It highlights issues of organization, teaching and learning, *schools infrastructure, school equipment, curriculum, evaluation, school governance, certification and values*. This document “*The child friendly schools infrastructure standards and guidelines*” - has adopted four clauses relevant to infrastructure and equipment from the “Rwanda Education Quality Standards 2008” and offers clarification and additional practical guidelines on how to achieve the standards.

**The four standards are as below table.**

#### Four standards of Child Friendly Schools Infrastructure

##### Standard A

“A school must have appropriate, sufficient and secure buildings”

##### Standard B

“A school must be a healthy, clean, secure and learner protecting environment.”

##### Standard C

“A school must have a child-friendly, barrier free environment which promotes inclusive access and equal rights of every child”

##### Standard D

“A school must have adequate and appropriate equipment that support the level of education.”

<sup>1</sup> MININFRA March 2009

## 1.4 Rwanda specific standards

It is vital to obtain standards specific and relevant to the current situation of Rwanda. This document is the result of a comprehensive consultative process where information was gathered from all regions followed by debate and analysis with a broad spectrum of stakeholders. The processes of the of drafting are listed below;

- a. Site visits to various types of schools in each regions.
- b. User group consultation including workshops with pupils, staff and interviews with head teachers.
- c. Working with MINEDUC schools engineers who has working knowledge of each region.
- d. Expert working groups were set-up for each standard.(refer to acknowledgements)
- e. Interviewing key experts / specialists.
- f. Study of MINEDUC's major school construction projects such as, BAD/ADB, UNICEF, and BCT/CREP.
- g. Study of regional building regulations such as the South African school standards.
- h. Study of international building regulations such as the UK building code, and primary schools design guidelines.
- i. Study of UNICEF guidelines on Child Friendly schools for Africa, Thailand and Iraq.
- j. Verification and feedback from regional consultation to district and school representatives. (total 218 participants)
- k. Reference to other documents (see bibliography).

## 1.5 Child Friendly Schools Approach

Rwanda Ministry of Education has adopted the Child-Friendly Schools approach which recognizes that each child is a vital member of society, and that every child's education is the key to the future of Rwanda's development.

The Child Friendly Schools approach, developed by UNICEF, puts the child at the centre of a holistic learning and teaching environment with six key dimensions. These dimensions are firmly embedded within these standards with the aim of creating an enabling physical environment fit for every child's education.

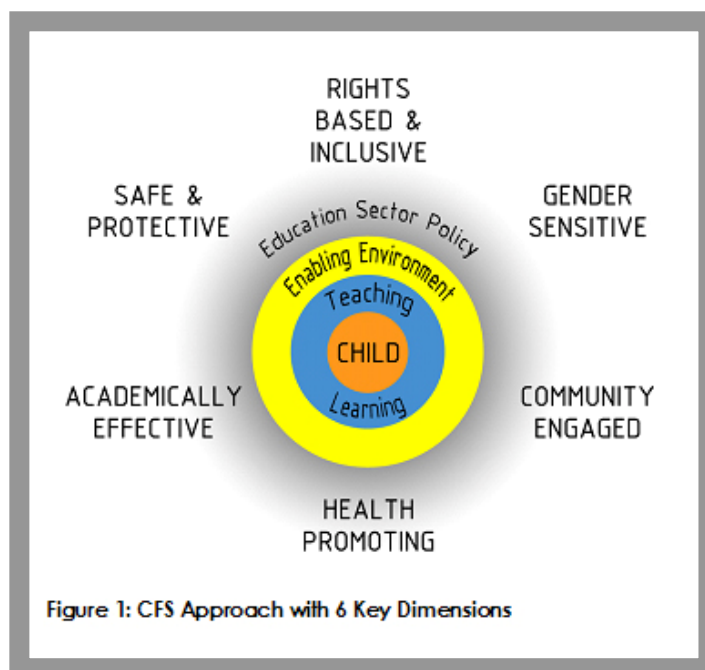

The six key dimensions which a school **must** consider are as follows;<sup>2</sup>

- 1. Inclusive of children;** Respects diversity, guarantees opportunities and meets the needs of children (based on vulnerabilities, social class, and ability level).
- 2. Secure and protective;** Helps to defend children from abuse and aggression; promotes psycho-socio-emotional wellbeing of teachers and learners.
- 3. Healthy.** Assure proper hygienic conditions by: adequate water and sanitation facilities; implementation of healthy practices.
- 4. Effective with children;** Uphold good teaching and learning processes; define quality learning outcomes; provides approved content, materials and resources; support teachers' capacity, commitment, income and their recognition of child rights.
- 5. Sensitive to gender;** Advocate gender equality in enrolment and success; guarantees girl-friendly facilities, environment and teaching; promote respect for other's rights and dignity.
- 6. Involved with communities.** Works to strengthen families; helps stakeholders establish collaborative relationships; works with other actors and duty-bearers to fulfil children's rights.

<sup>2</sup> UNICEF Child friendly Schools Guidelines for Africa

## Section 2 – Planning

### 2.1 Categorization grading of facilities

Common assessment tools are helpful to be used to gain an objective understanding of the situation of infrastructures this information when made available to all administrative levels can become vital for an accurate and targeted planning and monitoring exercise.

2.1.1 Categorization of schools are made here in accordance to the standards outlined in this document.

This categorisation 1-6 is a tool to assess the current condition of each school. It may also be used as a way to determine the expected standard for future schools. Category 4 is the standard set to be achieved, for the purpose of incremental progress and monitoring the standard, the must items have been divided into three categories in the order of priority. This table must be used conjunction with the check list..

category (infrastructure)	Descriptions
<b>Category 1</b> (Must items)	<b>Unfit for human occupation;</b> If any of the items required for basic human occupational needs “category 2” is missing.
<b>Category 2</b> (Must items)	<b>Facility fit for basic human occupation;</b> The entire school community is catered with all items within “Category 2”
<b>Category 3</b> (Must items)	Facility fit to carry out basic educational activity; The entire school community is catered with all the “Category 2+3” items.
<b>Category 4</b> The Standard (Must items)	Facility fit to carry out effective education: The entire school community is catered with all the “Category 2+3+4” items.
<b>Category 5</b> (Should items)	Above Standard facility; The entire school community is catered with all the “Category 2+3+4” items and some Category 5 items.
<b>Category 6</b> (May items)	Excellent Facility The entire school community is catered with all the “Category 2+3+4+5” items and some Category 6 items.

### 2.2 Schools Infrastructure check list

The table on page 8 is a simple check list for a quick assessment of schools infrastructures. Each infrastructure element must make allowance for all pupils and staff within the school. The outline requirements are illustrated against each infrastructure element and for technical details, standards and guidelines one must refer to the written document of each section.

2.1.2 Categories may also be made according to the construction type of the major structural element.

Construction types; major structural elements	Number of classrooms	Condition Good/ Medium/ Bad
a. Under a tree		
b. Under plastic sheet		
c. Mud walls - Rukarakara		
d. Fired Brick walls		
e. Stone walls		
f. Concrete Block walls		
g. Compressed earth block walls		
h. Timber frame		
i. Specify other.....		

## Schools infrastructure check list

category	✓	Infrastructure element	Section Ref	Outline requirements
<b>Category 1 Unfit for human occupation</b>		If any of the items under category 2 is not catered, the facility is deemed unfit for safe human occupation.		
<b>“MUST” items</b>				
<b>Category 2  Facility fit for human occupation All Items required</b>		Safe and secure class room	A.1.1	Minimum 1.0m <sup>2</sup> enclosed floor space per pupil at an adequate quality; internal temperature, ventilation, daylight, acoustics, waterproof and dust free safe and secure learning environment.
		Toilet and Hygiene facilities	B.2.1	Separate girls, boys and staff facilities with disabled WC according to ratio.
		Non-potable water supply with hand wash points	B.1.2/ 1.2.1	Access to 2-20 liters per pupil according to occupancy type.
		Safe drinking water	B.1.1	Access to 1-3litres per pupil according to occupancy type.
		Head teachers room	A.1.2	Adequate space for a table and meeting area, min 13 m <sup>2</sup> floor space.
		Accessible / Disabled WC	C.2.3	1 cubicle per gender.
<b>Category 3  Facility fit to carry out basic educational activity; All items required</b>		Have all “Category 2” items		
		School Furniture	D.1	Adequate quantity and size for teaching and learning for all rooms.
		Play / games area	A.1.7	Pupils must have access to play areas such as Basketball, Football, Handball, Netball, Volleyball, Table tennis.
		First Aid Kit	D.2	Minimum one full set maintained per school.
		Sanitary material	D.2	Sanitation products and equipment available to keep healthy
		Didactic material	D.2	According to curriculum General, Metric, Geography, Science sets.
		Sports equipment	D.2	According to schools needs Play, Basketball, Football, Handball, Netball, Volleyball, Table-tennis, and general kits.
		Staff room / Teacher resource room	A.1.3	Minimum 16m <sup>2</sup> floor area for 6 teachers and additional 2.6m <sup>2</sup> floor space per teacher.
<b>Category 4 The Standard  Facility fit to carry out effective education: All items required</b>		Have all “Category 2+3” items		
		Barrier free-access	C.2.1	Allowance of ramps, doors and smooth floor surface to allow disable person’s access to majority of facilities.
		Fence	B.4.1	Secure fence gate to the entire perimeter of school grounds.
		ICT room with electricity	A.1.6/ 2.9	Tronc Commun schools must have ICT room with adequate equipment and a supply of electricity.
		Special needs room	C.2.7	The school must have a special needs room.
		Drainage	B.3.3	Sufficient drainage to avoid stagnate water.
		Storage space	A.1.4	10-15m <sup>2</sup> floor space: adequate secure storage for didactic materials, sports equipment and cleaning material.
		Science Laboratory	A.1.5	Must have dedicated science lab for Tronc Commun schools.
<b>To conform to standard all items with in Category 3,4 and 5 must be catered for all school community.</b>				
<b>“SHOULD” items</b>				
<b>Category 5  Above standard facility Recommended Items</b>		Must have all “Category 2+3+4” items		
		Outdoor learning area / Habitat area	A.1.8	Allowance for outdoors teaching. eg. school garden, shaded area or area for live stock.
		Rain water harvest system	B.1.3	Appropriate system to obtain clean water.
		Tactile surface	C.2.7	Floor surface treatment to guide the blind.
		Incinerator	B.3.2	A safe system for incinerating organic flammable waste.
		Compost	B.3.1	A system to decompose organic material into soil.
		Energy efficient stoves	2.9.1	For schools with cooking facilities, to reduce energy usage.
	Sign post / Signage	2.6 / C.2.5	Clear sign post at the entrance and signage to each room.	
<b>“MAY” items</b>				
<b>Category 6  Excellent Facility</b>		Must have all “Category 2+3+4+6” items		
		Use sustainable construction material	2.10	Use of Compressed earth blocks
		Uses sustainable energy	2.9.4	Use of solar energy, energy efficient stoves, biogas plant.
		Multi-purpose hall	A.1.10	According to school needs assembly, dinning, performance.
		Kitchen	A.1.12	Adequate space for safe clean cooking, washing, storage.
	Medical sick room	A.1.11	Adequate space for sick bed and desk.	

### 2.3 Refurbishment / Upgrading

When there is the need to decide whether to refurbish, remodel or construct a new building, it is vital to make a feasibility study to make an informed decision. This study must outline the associated benefits of each option. One **must** consider structural safety and quality of learning space, against costs and timing for each option. Consider the life cycle costs as a total, eg. Durable construction which lasts longer can be more economic in the long run.

### 2.4 Urban / Rural

There are fundamental differences on what is suitable for urban and rural sites. For example Kigali city has a master plan which must be respected and consents gained prior to construction. Other key differences which will affect infrastructure solutions are;

**a. Density and the availability of land.** This affects the size of buildings and sports pitches which can be accommodated. Single storey building is preferred for primary schools due to access and escape reasons. However, if a multi-storey option is taken, access strategy for learners with special needs and exit strategy/routes must be considered carefully.

**b. Access to water and electricity.**

**c. Difference in appropriate sanitation systems.**

### 2.5 New site selection

When selecting a new site for a school the following aspects must be considered before the project starts. All providers must inform the district of the proposal and must gain approval from the district or city authorities.

Proposals for new school sites must include the following information to demonstrate the suitability of a project:

- a. Must** demonstrate the need for a new school through the consideration of population of school age children within the catchment area.
- b. Must** demonstrate that the majority of pupils will travel no more than 2km to attend school.
- c. Must** demonstrate the school will be placed in a location with good access to roads and possibility of obtaining clean and safe drinking water.
- d. Must** demonstrate that the size of site is sufficient and can accommodate to number of pupils planned.
- d. Must** demonstrate that the site is located away or protected from environmental risks and hazards (natural and man-made) i.e. from flooding and landslides.

**e.** Ideally select land with gentle incline so that it is easier to make the ground level accessible to wheelchair users, access and outdoor facilities. The gentle incline will help with the site drainage, if a sloped area cannot be avoided, a platform **should** be built first and the buildings **should** be placed at a secure distance from the adjacent slopes as per diagram.

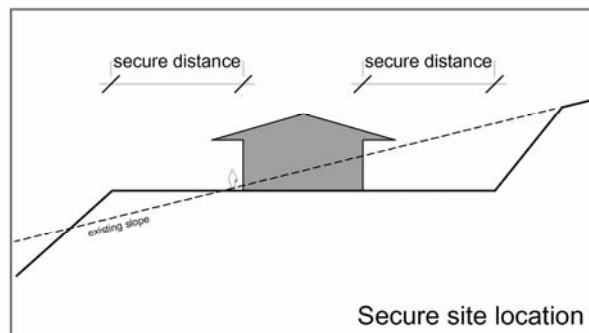

**f.** School buildings and facilities **must not** be located on or below an active or potential slope movement zone. Indicators for slope movements can be: inclined trees, previous land slides, irregular slope surface and wet and muddy soil.

**g.** If steep terraced site layout cannot be avoided, slope protection measures **must** be taken in order to prevent dangerous soil erosion from the surrounding environment. Some measures may be:

- **Use of retaining walls** such as gabion wall construction –(cage or dry stone construction), concrete walls, masonry or natural stone walls.

- **Use of vegetation** such as planting of trees, scrubs and grass according soil condition and steepness of slope.

#### 2.5.1 Natural features

Natural features analyses are required when selecting suitable sites. This is particularly important in Rwanda's hilly landform with steep slopes, wetlands, drainage ways and forests.

**a. Avoid steep slopes**, as they generally have the following increased risks: landslides; erosion; problems with road designs, construction, and maintenance; as well as difficulty with access especially by fire protection equipment and emergency vehicles.

**b. Avoid wetlands**, as they are a vital ecological asset to the country side. Also much effort is required to stabilize the ground conditions to build on these sites. Also they are breeding ground for mosquitoes which is a health hazard. Note; Most species of mosquito can fly a distance of 1-3km which can carry diseases try to locate a school a safe distance from mosquito breeding grounds.



**c. Avoid cutting down trees;** the protection of mature trees is a major component to ensure environmental sustainability. Trees are critical features of ecological integrity in many ways. They act as soil stabilizers because they protect from erosion. They also help maintain and stabilize hydrological cycles, protect from flood, reduce heat absorption, purify the air, and reduce evaporation. They beautify the environment and provide habitat for birds and other wildlife.

**2.6 Site layout for schools** (Refer to site zoning plan below.)

If possible the school building should be orientated that the windows face north and south to avoid light penetration into the class rooms.

The facility should give a welcoming atmosphere by locating a supervised external entrance area around the main entrance/ gate. A clear signpost with the school's name and location should be installed at the entrance. The administrative block which houses the staff room, the head teacher's room, sick room and storage space is best located close to the entrance to allow supervision and easy access by the community, such as parent meetings.

The classroom and resource/science blocks may

be organized to form a central assembly/external courtyard space to create a sense of security and focus. This area should be kept open and flexible to be useable for many activities.

The toilet blocks for the girls and boys must be separated and allow visual and acoustic privacy. Passive supervision from the classrooms or administrative block is good practice. The staff toilets should be in separate blocks.

The main games area should be located at a distance away from the class rooms to prevent noise disturbances to the classes.

When planning the site layout, future expansion should be taken into consideration in the overall site layout and natural features such as mature trees rocks should be considered.

Primary school buildings are usually single storey, to allow flexibility in organization, easy access to common resources and outdoor areas, and easy movement of disabled people and trolleys carrying teaching equipment. However, in urban areas multi-storey building maybe more appropriate. Access for disabled people may become a challenge. Ramps to the upper floor when possible, or one can re-organise classes with disable pupils to be located

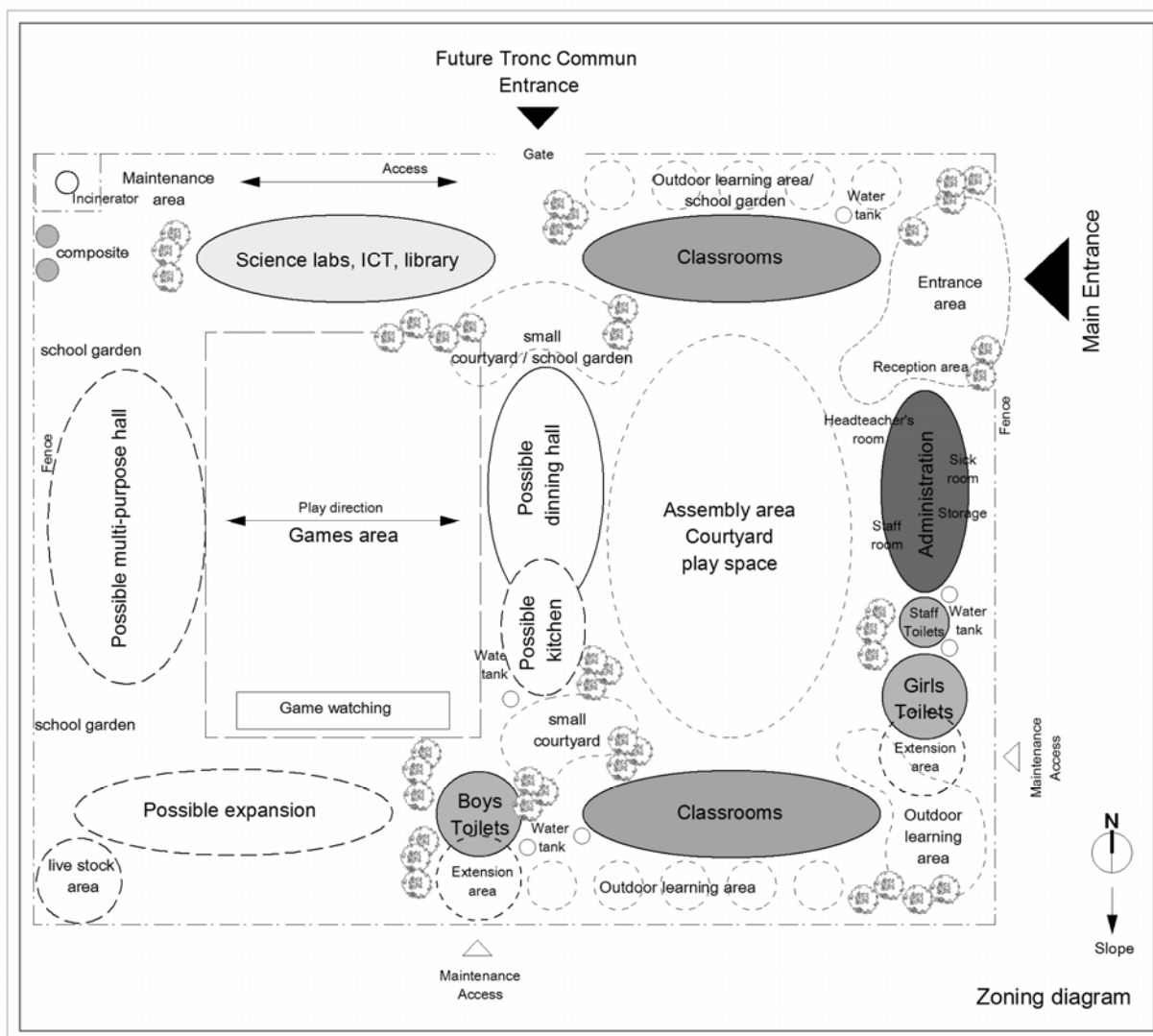

on the first floor. The main elements - the class rooms - are to be grouped to allow the sharing of resources -quiet rooms and practical areas- with easy access to the library and other common areas such as the hall.

### 2.6.1 Flexibility and expansion

The education system is undergoing major transformations<sup>3</sup> such as the introduction of double shifting, priorities in science and technology and the introduction of 9 year basic education facilities. In this rapidly changing situation it is essential for the schools to plan for flexibility and expandability of its infrastructure.

#### Flexibility

Consider class rooms which can be interchanged with minimum disruption between classes from different levels or different curriculum and to allow for possibilities of double shifting. Flexible furniture can enable a more interactive teaching method. (refer to standard D.1.)

#### Expandability

Consider the ability to expand or contract the facilities when planning the site layout of a school. Consider allocating space for additional class rooms, halls, kitchen, and sanitary facilities from the outset. The allowance will depend upon the projected pupil enrolment rate and the availability of land.

## 2.7 Atmosphere of the school

Physical infrastructure requirements of a child friendly approach: The physical environment **must** suit the identity, ethos and culture of the school's overall vision.

A school **must** ensure that;

- a. It is devoid of genocide ideology and other divisive tendencies.
- b. It is absent of physical punishments, inhuman and degrading treatments.
- c. It offers an appropriate, comfortable, adaptable and stimulating learning environment to improve

educational performance.

d. It offers staff satisfaction, through appropriate space for all staff to work rest and socialize.

e. It offers pupil satisfaction, for example, buildings that support good behaviour and self-esteem and, ultimately, the willingness and ability to learn.

f. It offers community and encourages parental involvement, which is an important way to make the school part of the community and maximize the use of facilities.

## 2.8 Disaster Risk Reduction Strategy

In the event of natural or political disasters, such as earthquake, strong winds, flooding, conflict, times when the communities need a place of refuge; public buildings such as schools may be used for temporary shelter. Schools can be suitable places as they are usually close to the community. If the facilities are considered as an emergency shelter or collective centres<sup>4</sup> as an emergency relief strategy the building must be maintained in a safe and secure manner. (Refer to standard A) However, if the emergency prolongs, an alternative shelter solution must be found to enable the education of the pupils to continue.

## 2.9 Energy

An effective educational administration requires adequate equipment which in turn requires energy/electricity. Every school **should** have the appropriate level and supply of energy.

A school **must** have the appropriate level of energy supply to maintain an effective teaching environment.

When making allowance for energy, follow the following steps as per diagram below;

- a. Determine the **needs**
- b. Calculate the **quantity**, dependent upon the number of class rooms / number of pupils / whether pupils take food at school / whether pupils board / operating times and double-shifting
- c. Explore the best energy source options for the

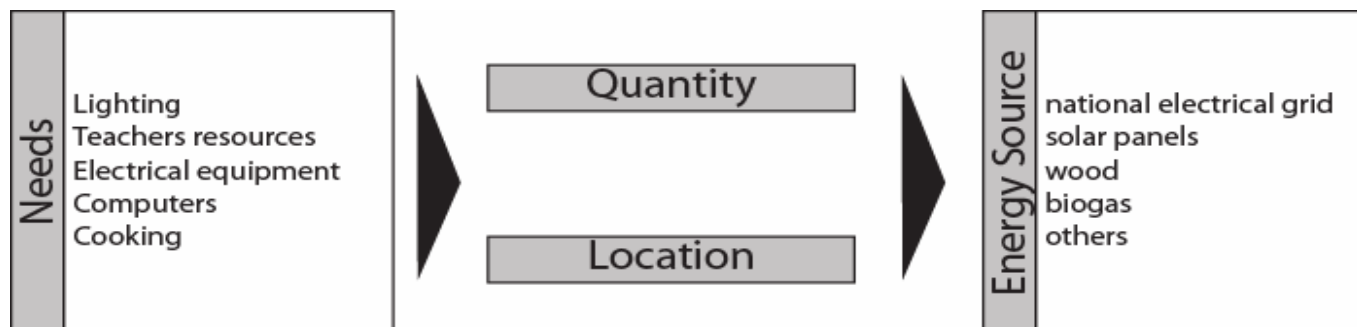

<sup>3</sup> MINEDUC 2009 strategies

<sup>4</sup> Transitional settlement displaced population Corsellis and Vitale

specific school. i.e. connecting to national grid, using solar panels, burning wood, biogas etc..

### 2.9.1 Energy needs and equipment

Energy needs of a school depend upon many variables, curriculum, teaching hours and type of equipment used. Energy efficient equipment or “Renewable Energy” appliances should be used to reduce the running cost and to fight climate change. Renewable energy appliances are equipment such as computers which are tailor-made for the renewable energy source market.

#### a. Class room lighting

Lighting needs for a class room depends upon the operating times of the classes. Typical class rooms require 3 numbers of 15 Watt CFL bulbs which are fixed to the level of the underside of the trusses, or at ceiling level.

#### b. Teacher resource room

Common equipment desirable in the teacher resource room include PCs, Printer, Copier, TV,DVD/VHS player, LCD projector, Radio, cassette player.

#### c. Computers

The amount of computers in each school will vary, below are typical energy consumption rates for each type of computer. The amount the energy available and can be budgeted by the school to power the computer should be considered carefully.

- |                         |              |
|-------------------------|--------------|
| a. Desktop computer     | 300 Watts    |
| b. Laptop computer      | 45-110 Watts |
| c. One laptop per child | 2 Watts      |

#### d. Fuel efficient cooking stove

Open fires used in the kitchen require a lot of wood and contribute to pollution, to health problems such as respiratory diseases, cancers and eye diseases. Schools which offer meals or boarding facilities should have fuel efficient stoves to minimize the energy requirements. Fuel efficient stoves have high combustion efficiency: the higher the combustion efficiency the greater the amount of heat produced and less smoke produced from the same amount of wood. By controlling the type of fuel used, burn intensity, air and flame mix it is possible to achieve efficiencies. The use of this type of stove reduces wood consumption and efficient stoves can use dramatically use less fuel.

The efficiency is gained by the good transference of the heat from the fire to the pot by;

- Good heat transfer at the base of pot.
- Improved heat retention by having thermal insulation surrounding the pot.
- Shortening the fire flow path.
- Reducing the distance between the flame and pot.

**Minimal smoke emission:** High combustion efficiency and drawing the smoke through a chimney and venting it to the outside of the home or away from the operator may achieve almost 100% reduction in emissions. The opening to the chimney needs to be designed to draw the smoke up it but at the same time to constrict the flow so that too much heat is not lost up the chimney.

**Ergonomics and structural stability:** Stove layout must be user friendly and enable pots to be moved around. The stoves and the pots must be stable when they are on the stove to prevent them from tipping over and causing burns.

**Materials:** Stoves can be made from a wide range of materials including clay-lined mud, metal or volcanic stone (available in the Northern region) lined metal.

**Fuel types:** Stoves which can take a variety of fuels such as briquettes, wood, bio-gas have been developed.<sup>5</sup>

**Biogas:** For boarding schools bio-gas system is encouraged to be installed to reduce the non-renewable fuel usage. For primary / Tronc Commun schools the continued inputs of raw material is an important issue to manage if biogas are to be used.

### 2.9.4 Sustainable energy source

Due to the depletion of non-renewable resources it is encouraged to consider renewable energy. Renewable energy should aim to provide at least half of the total energy demand dependent upon the following criteria. Further guidance can be found from Rwanda Environmental Management Authority and UNDP energy section.

The following criteria should be used as a guideline for the determination of an appropriate energy source:

- Simple and durable technology: Easy to install, easy to operate and easy to maintain.
- Low operational and maintenance costs.
- No additional technical personnel necessary for its operation at school level.
- Adequate technicians for installation and maintenance are available at regional level.
- Spare parts are available in Rwanda.

<sup>5</sup> For more information refer to Kigali Institute of Science and Technology, Centre for Innovation and Technology Transfer

### 2.9.3 Accessibility to electrical supply

#### A.2.7 Electricity

All schools **must** have electricity suited to the needs. The source of electricity will depend on the needs and accessibility.

Recommendations from MININFRA stipulate; schools which are located at a close distance to the power grid (0 to 5 km) **should** be connected to it. Schools which are further away than 5 km from the power grid and are expected to be connected to grid over the near future should use a mix of alternative energies to meet their energy demand (e.g. solar power and biogas).

Schools which are already connected to the power grid may use alternative energies as a supplement.

### 2.9.4 Safety

Any on-site energy production must not create any potential dangers to pupils, teachers and other school users.

#### 2.10 Appropriate construction technology and material

Aggravated by the 1990-94 civil war, which destroyed existing resources, delaying economic recovery, overpopulation and dependence on land has led to deforestation, degrading of soil, leading to soil erosion and destruction of environment. Rwanda currently relies heavily on imported goods as prices of these goods and services continue to rise. There is a perceived need for expensive imported materials which increases pressure on the local economy to buy those imports. Construction projects are resource intensive and have immense impact on the environment and climate change. It is with this understanding that each construction project must consider the benefits of appropriate material or technology.

Encouraging the use of local materials which prevents the over use of timber, cement and reduced transport costs will not only stimulate local industry and economy but will safeguard the environment. However, if we do not continue to make effort to explore more sustainable options, the country's construction industry will continue its dependency on typically unsustainable industry elsewhere which contributes to global warming.

#### Reducing the use of cement;

Cement is local only where it is produced and the cost is driven by energy costs. Cement has 1.25 tonnes of CO<sup>2</sup> emissions for every tonne of cement produced. Cement travels long distances even if they are from a local producer and prices inflated due to import taxes. Thus with these points in mind it is favourable to find construction methods which are durable but use less cement.

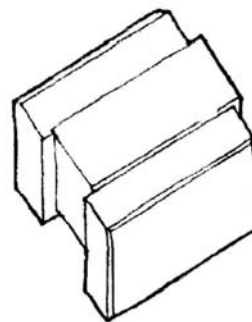

A diagram of a typical CEB

#### Compressed earth blocks;

It is with this understanding in the current context of Rwanda that Compressed Earth Blocks (CEB) presents a real alternative to the traditionally used construction materials such as concrete hollow blocks and burnt bricks.

Compressed Earth Blocks comes in a number of different formats, from fully commercial products, some containing cement or other stabilisers (stabilised blocks), to those which rely on their composition and compaction to gain strength (unstabilised blocks).

Machines such as *Hydraform* which have been used in Rwanda for various projects can be used in-situ to use local soil and greatly reduce transport costs. Also the usage of cement is greatly reduced as Compressed Earth Blocks can be formed to interlock and negate the need for mortar.

Un-stabilised block in particular need careful detailing and finishing ensuring a comparable life span to more energy intensive materials.

Combining stabilised and non stabilised elements is something which should be done as a matter of course. The innovative ways to the use of stabilised CEB at the bottom of the wall with the use of unstabilised block on the upper wall are ways to reduce cement usage. Technologies such as CEBs may be used to ensure resistance to water ingress or for selective use in areas with greater exposure to risk, as corners or piers.

What both each of these share is the ability to reduce transport distances and increase local material and labour inputs. This technology is being implemented in country lead by institutes such as KIST/CITT.

As demonstrated by the table below; cement stabilised blocks and unstabilised earth systems need not suffer from poor durability when the building design [footings, roof overhangs, siting etc] are considered carefully. Also CEBs and other technologies can benefit from surface coatings which can be applied at the time of building or further down the lifespan of the building.

But simple compressed soil blocks and similar technologies can also be used within the build up of the shell to both reduce costs and increase confidence in their inherent properties.

For instance lightweight cement blocks and thin brick walls are less thermally stable than thicker locally available CEBs [stabilised or not]. Subsoil for CEB's [stabilised or not] do not require agricultural soils or forestry products either for structural stability or for burning.

As the country is built upon "Thousand Hills" it is common for the building site of the school to excavate. This produces sub soil which can be utilised to produce the CEB for the building.

a. The below chart compares the three most common construction materials for wall construction in regards to different important indicators: (2008)

Legend:           +++: good  
                          ++: ok  
                          +: poor

Wall construction material comparison			
Property	Burnt bricks	Concrete blocks	Compressed earth blocks
Durability	+++	++	++
Rain resistance	+++	+++	++
Moisture impermeability	+++	+++	++
Fire resistance	+++	+++	+++
Low sound transmission	++	++	+++
Time taken	+	++	+++
Economical Life span	+++	++	++
Environmental sustainability (embodied energy)	+	+	+++
Material unit Cost (2008)*	+	+	+++

\*Cost per meters squared (m<sup>2</sup>) of wall is as follows in 2008:  
 1. Burnt bricks: 16,000 Rwf  
 2. Concrete blocks: 14,500 Rwf  
 3. Compressed earth blocks: 12,000 Rwf

b. The below chart compares the three most common construction materials for roofing in regards to different important indicators: (2008)

Legend:           +++: good  
                          ++: ok  
                          +: poor

Roof construction material comparison			
Property	Painted corrugated iron sheets	Unpainted corrugated iron sheets	Tiles
Durability	+++	++	++
Fire resistance	+++	+++	+++
Low sound transmission	++	++	+++
Waterproof	+++	++	+++
Time taken to construct	+++	+++	+
Economical Life span	+	++	+++ expensive roof structure
Environmental sustainability (embodied energy)	+	++	+
Material unit Cost (2008)*	+	++	+

\*Cost per metres squared (m<sup>2</sup>) of roofing is as follows in 2008:

1. Painted corrugated iron sheets: 4,000 Rwf
2. Un paid corrugated iron sheets: 3,500 Rwf
3. Tiles: 3,300 Rwf

When selecting the appropriate construction technology and materials the following questions **should** be addressed:

- a. Consider environmental sustainability
  - Does the material suit the local climate?
  - Can you procure the material locally?
  - Does the material require excessive transport costs or fuel usage?
  - Will the harvesting of the material contribute to deforestation?

b. Consider economic sustainability

- Are there opportunities to hire local labour and skilled workers?
- Are there enough stock material in the district, region, and country to supply the construction?
- If the material needs to be scoured from a far, consider transport financial and ecological costs.
- Consider the effects on local market when procuring bulk material. ie. Inflate prices or dry-up the local stock.

c. Consider social sustainability

- Is the material accepted by the community?
- If not consider re-think if it is the appropriate material for the location.
- if it is considered the best material communicate the benefits and demonstrate the technology to the community.

**2.11 Community involvement**

Strengthening and establishing collaborative relationships between the school, families, children and stakeholders helps to create one of the key dimensions of a Child Friendly School. The way in which the school infrastructure is designed and managed can assist in developing strong partnerships between the community and school. The Communities involved **must** be considered throughout the process, from planning, design to construction and maintenance.

2.11.1 Community involvement in the design and construction process

- a. Consult school community including staff, children, villagers, in the planning and design of the facility.
- b. Establish a complaints mechanism
- c. Include the community in the bidding process by publicly posted tenders or community procurement committees.
- d. Inform the community of project progress.
- e. Request the community for assistance to prepare the site.
- f. Request community support of school maintenance. – Careful planning and clear understanding between school and community are essential for a successful community support.

2.11.2 Sharing the use of school facilities

When the school facilities are not in use it may be offered to the community. Examples such as class rooms used for **adult learning classes** or for **community meeting**. However it must be noted careful management and agreement between parties are required.

2.11.3 Community involvement in construction and maintenance.

When asking the community for support, clarification is required by the school is whether the community is to be on a paid or on volunteer basis.

The mobilization of the community will bring many benefits however the quality of the end result **must** not be sacrificed. The list below outlines possible ways in which communities can contribute to the schools construction.

- a. Build teacher accommodation
- b. Build student accommodation
- c. Supply locally procurable material
- d. Supervise construction site, monitor quality.
- e. Prepare vegetable garden
- f. Make and maintain rubbish pit and composite
- g. Provide food for workers
- h. Provide funds
- i. Prepare the school grounds and sports area
- j. Offer paid labour for building
- k. Offer un-paid labour for building
- l. Plant trees
- m. Source land
- n. Build the fence

**2.12 Curriculum -9 year’s basic education**

The adopted government policy to change basic education from six years to nine years has considerable impact on schools infrastructure. This aspect must be carefully considered in the planning of the school. To 2008; many Tronc Commun had been conducted at secondary schools. The table below outlines the core age groups within each educational level.

	<b>Educational level</b>	<b>Age catchment</b>
	Pre-Primary	S1-PS3 3-6 years old
9 year basic education	Primary school	P1-P6 7-12 years old
	Tronc Commun	S1-S3 13-15 years old
	Upper secondary	16-18 old

In recent years (2008-9) five districts have been implementing phase one of the 9 year basic facilities programme. For further guidance contact MINEDUC for up-to date programmes and policy.

### Section 3 - Standards – guidelines

#### Standard A

**“A school must have appropriate, sufficient and secure buildings.”**

#### A.1 Schedule of accommodation

This section sets the space requirements and the standard of the quality of those spaces.

##### A.1.1 Class rooms / Basic teaching areas

The design of classrooms **must** be comfortable, (refer to Standard A.2), accessible (refer to standard C), flexible (refer to standard D.1.2) and adaptable and provide sufficient space to ensure children’s dignity, health, safety, well-being for successful learning.

##### A.1.1.1 Internal Floor Area

Rwanda targets a maximum class room size for **46 pupils per class room**. A standard class room **must** make provision of a **minimum 1.0m<sup>2</sup> floor**

**space per pupil** recommended area of 1.2m<sup>2</sup> per pupil. The furniture type will dictate the area requirement within this floor area range. Floor area is calculated from internal wall to internal wall, as shown in the diagram below. Dimensions are not provided in the standard as the size of room will depend on each project considering number of pupils, site area available.

##### A.1.1.2 Class room layout

**a. Two mean of exit should** be provided. This is to allow a second means of escape in case of fire, security incident or earthquake. The pupils **must** be able to escape to safe grounds as indicated on the diagram below. The second door must be able to be used as emergency exit and able to be opened from the inside without the use of a key.

**b. Avoid steps** into the class room (refer to C.2.1 b)

**c. Two blackboards should** be installed in each room.

**d. A Cupboard** to store books and notebook **should** be available in each class room.

**e. A Display area / science corner:** Allow a wall space sufficient for displaying didactic materials within the classroom.

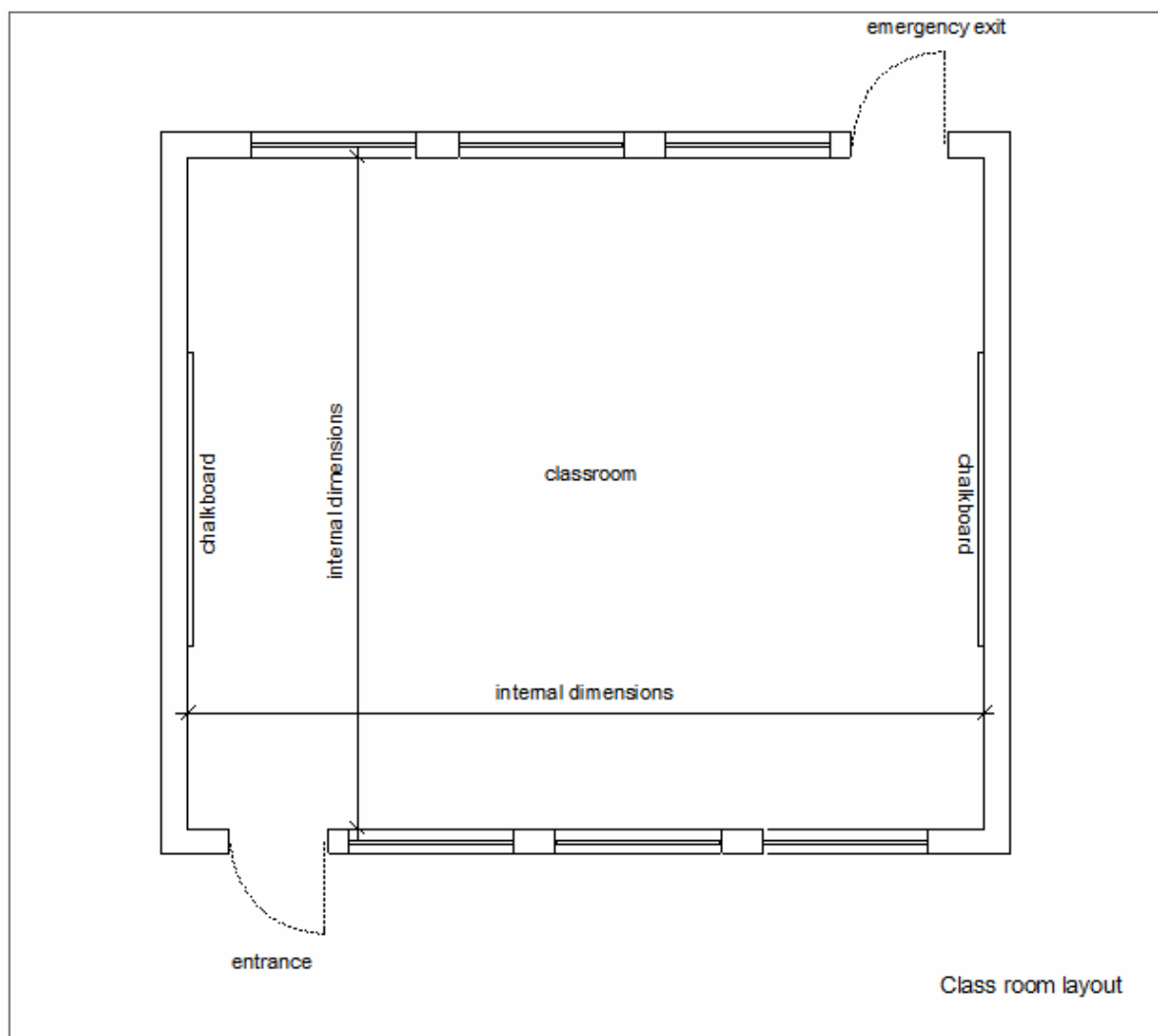

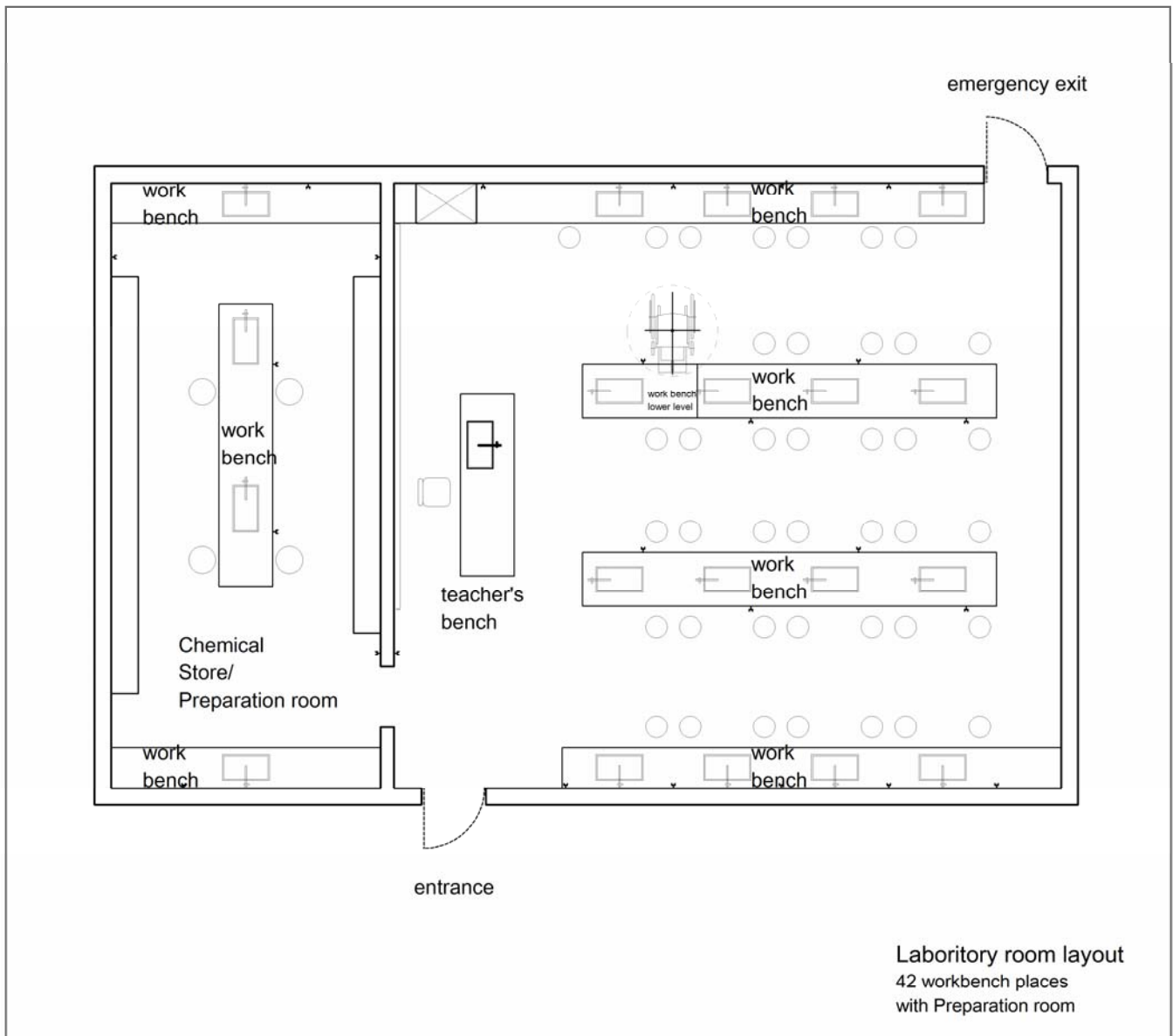

According to the curriculum additional space allowance for Science, ICT, Library or Cooking **may** be added to the standard class room size.

### A.1.2 Head teachers room

A school **must** have an office for the head teacher. The room should have adequate space for a table, chair and cupboard, plus area to hold meetings. Recommended area is **minimum 13m<sup>2</sup> floor space**.

The head teacher's room should be located close to staff rooms, as well as located where there is good connection surveillance to the main school grounds.

### A.1.3 Staff room / teachers resource room

A school **must** have a work and social space for teaching staff. This room will be used for preparing for class, a place to exchange information among teachers and a place to take a break. This can be either a staff room or teacher resource room. For equipment within teachers' resource room, refer to standard D.

Staff room / teacher resource room should be centrally located to provide surveillance of the school grounds.

A standard Staff room / teacher resource room should be **minimum 16m<sup>2</sup>** floor area for up to 6 teachers and 2.6m<sup>2</sup> floor space per additional teacher.

### A.1.4 Storage space

A school **must** have a safe, secure, lockable and dry storage space for didactic material, sports equipment and cleaning material. The recommended space is in the range of 10-15m<sup>2</sup> floor area. This store **must** be located in a location easy to be monitored by a member of staff or care taker.

### A.1.5 Science Laboratory

Refer to sample laboratory layout diagram above. For Tronc Commun levels a laboratory **must** be provided. A Laboratory should include sufficient workbenches with basins and water supply for the pupils. A separate teacher's workbench should be located to the front of the class room to allow demonstration to be observed by all students



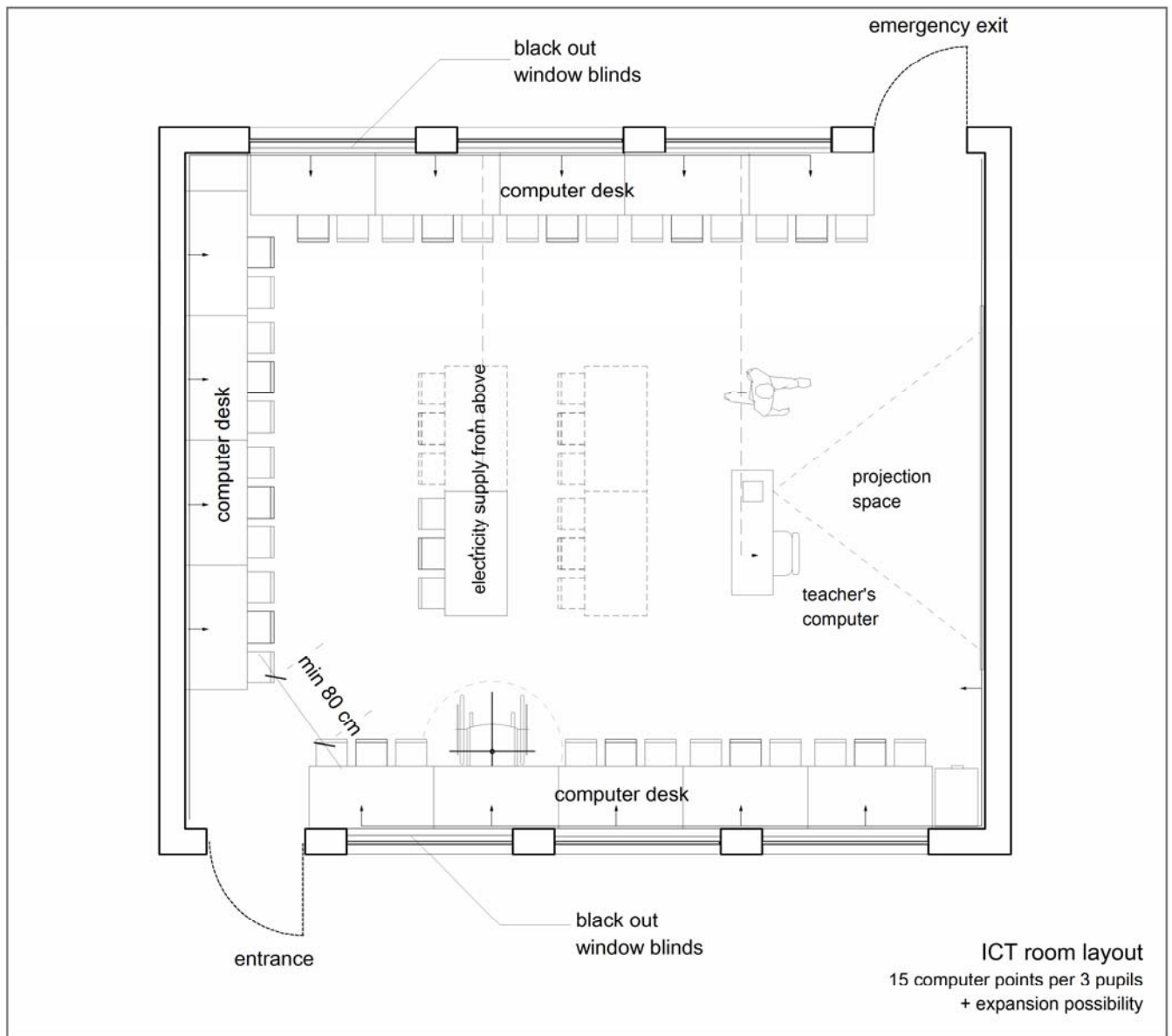

equally. A separate lockable chemical store/preparation room should be located adjacent to the main laboratory with workbenches with basin and lockable storage space.

### A.1.6 ICT room

Dependent upon many factors, such as availability of electricity, availability of computers and the availability of ICT educational programmes, Tronc Commun schools **should** make allowance for ICT teaching and primary schools **may** make allowance.

This allowance may be made by a room dedicated to ICT or through making allowance within the class rooms.

ICT allowance within the class room can include electrical power sockets or laptop charging stations and the ability to re-organize furniture.

Dedicated ICT rooms **must** have the following qualities;

Dust free, good ventilation (to prevent over heating due to the heat from equipments) and no glare by providing window blinds and lockable.

The ICT room **should** be organized in such a manner that students can share the computer stations and an area to the front of the class room should be kept clear for projections. The room may be organized in such a way that it allows easy electrical supply to the computer stations, preferably along the wall by cable trunking to secure cables from damage. If computer stations are located to the middle of the room the electricity supply/cable trunking should be from above and not over the floor to avoid trip hazards.

Note: Electrical sockets **should** be mounted at 450mm centre above finished floor level to allow a person in a wheelchair to access the sockets.

### A.1.7 Play/ Games /leisure area

Sports and play are a fundamental need for the pupils' education. **A school must offer access to play grounds, leisure areas and sport pitches.** Refer to sample playing field plan below for basketball/Volleyball pitch and Football pitch.

Locations where land is limited or that the school is within a difficult terrain. Alternative solutions to enable pupils to gain access to play grounds should be explored. Solutions such as using community fields can be alternatives.

**a.** Common sports played in primary and Tronc Commun schools in Rwanda are: Volleyball, Basketball, Athletics and Football. Refer to equipment list in Standard D.

- b.** The pitch **must** be level with a smooth surface.
- c.** The surface **must** not be hazardous.
- d.** Shaded outdoor play areas **should** be provided, such as groups of trees or canopies.
- e.** The creation of sports pitches and its maintenance may be carried out by community work, Umuganda.

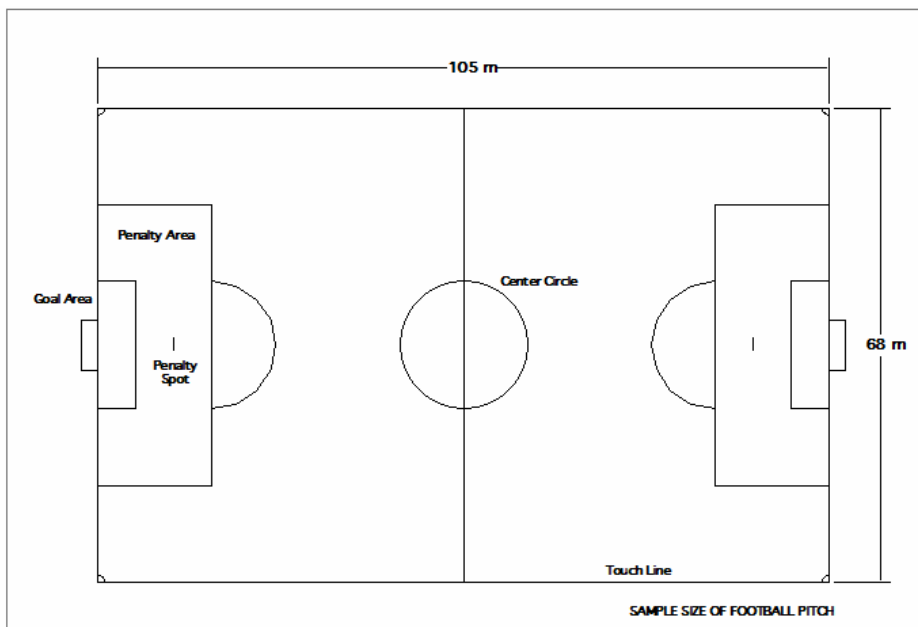
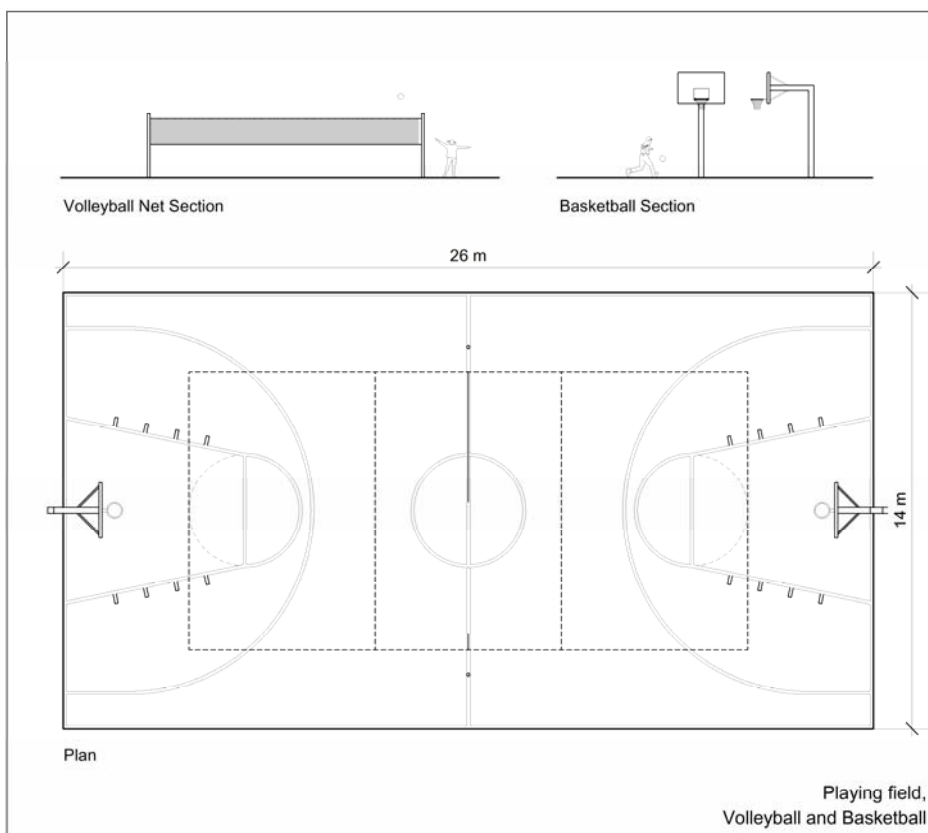

### A.1.8 Outdoor learning area / Habitat area

Schools should have **outdoor learning areas** which are spaces where formal or informal teaching can take place. These spaces **may** be directly connected to the class rooms or located centrally as a court yard. These areas **may** have a variety of qualities; it **may** be enclosures created by vegetation with external furniture.

Schools should also have habitat areas where the school community grows flowers, vegetables and trees and/or keep livestock ie cows, rabbits, pigs, chickens etc. which may be used for hands on learning.

### A.1.9 Library / Learning resource area

A school **must** offer facilities for storing and displaying educational reference materials to cultivate the culture of reading and researching.

This room **may** be a centralized room i.e. a library or a corner with shelves within each class room as a learning resource area.

The consideration of accessibility of pupils with SEN and disabilities is particularly important for these spaces. Refer to standard C.

### A.1.10 Multi purpose hall

A multipurpose hall **may** be built after the basic requirements of a school are met. A hall may be of various sizes and various degrees of enclosure according to the intended use.

The hall **may** be used for assembly dining, physical education, music, drama, and for parents' meetings and social events.

Halls can contribute to the community as venues for gatherings such as public performances, music, drama, debates and presentations. Thus it **must** be easily accessible to visitors.

Dependent upon the use of the hall, ancillary spaces, such as stores for equipment and dining furniture, an adjacent kitchen with serving area and WC facilities **should** be provided.

### A.1.11 Medical sick room

A medical sick room where sick pupils can rest until they are picked up by parents **may** be offered in a school. This room may also be used for visiting therapists or other support for pupil with SEN and disabilities. This room may furthermore be used for pastoral support and interviews which requires privacy.

This room **should** be near staff / administration area a near the school entrance.

However a school **must** have a medical first Aid kit available. Refer to standard D.2

### A.1.12 Kitchen

Schools **may** have kitchens but when they offer meals, the school **must** have adequate and hygienic kitchen area. The size of the core preparation area will depend on the equipment needed, number of pupils and also the effective number of sittings.

Kitchen facilities **must** include:

- a. Facilities for preparing food and safe drinking water.
- b. Areas for washing up afterwards from a clean water source.
- c. Adequate facilities and area for safely preparing and cooking food with energy saving stoves with an effective chimney to extract smoke.
- d. Separate facilities for storing cleaning materials.
- e. Separate secure storage for dry goods.
- f. Adequate circulation for goods in and waste out.
- g. Adequate facilities for disposal of waste.

## A.2 Spatial qualities

### A.2.1 Internal temperature

Internal Temperature of a class room **should** be at a comfortable level. Over-heating of rooms **should** be avoided as it reduces the pupils' concentration capacity.

Over-heating and glare **should** be controlled by adequate solar shading by the use of overhanging eaves to windows, and also can be prevented by the siting the building so that the windows face north and south.

In hot climates classrooms **should** have a ventilated ceiling to reduce heat transmission and the planting of vegetation can dramatically reduce the surrounding temperatures

### A.2.2 Ventilation

Rooms **must** have adequate ventilation to maintain a healthy internal environment.

Design **must** allow adequate fresh air in take through openable windows. **Minimum openable window area is 5m<sup>2</sup>.**

Air flow **should** be maximized with cross-ventilation, openable windows should be situated on opposite sides of the room.

Ventilation **should** be maximized in hot climates to reduce inside temperature and minimized in cold-climates to retain the heat.

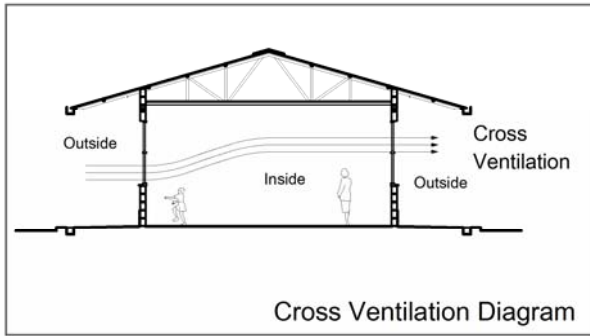

### A.2.3 Day Lighting

Daylight **should** be the main source of light. Ample natural light and good illumination levels **should** be provided.

Where there is no glass fixed to the opening, when it rains the shutters **must** be closed and then the class room becomes totally dark, so the class has to pause until the rain stops.<sup>6</sup>

The use of glazed windows or other solutions **should** maximize the use of natural light.

Adequate light levels **must** be achieved by providing unobstructed window area of 12m<sup>2</sup>.

Window openings **should** be equally spaced on two sides of the room to avoid dark corners. It is especially critical is to have good lighting at the chalkboards and desktops.

### A.2.4 Acoustic

Each room or other space in a school building **must** be designed and constructed in such a way that it has good acoustic conditions appropriate to its intended use.

a. The school design **must** consider reducing noise penetrating class rooms from the out side. Noise from the playground, main road or traffic is to be minimised so not to disturbed the pupils.

b. The school design **must** consider reducing noise transfer between internal rooms i.e. Class rooms

c. The class room **should** consider the reduction of echos within the class room through use of sound absorbing surfaces and furniture.

d. The building **must** reduce any noise created by rain or wind. Example; *“corrugated iron sheets roofing creates such noise when it rains that the class has to be halted.”*<sup>7</sup>

e. Roof noise **should** be prevented while designing and choosing materials. Roof insulation might be used.

f. Noise from the surroundings **should** be avoided while selecting and locating the site.

g. Location of sport grounds and open areas **should** take into account classrooms layout to isolate them from distractive noises.

### A.2.5 Water penetration

All buildings **must** be water tight.

a. Roofs **must** not leak. Adequate gutters and or site drainage channels **must** be installed.

b. Water **must** not penetrate through walls

c. Water **must** not be able to enter the class rooms. Add a small slope away from the door or refer to clause C.2.1.b for the acceptable step height.

d. Roof over hangs, eaves **should** protect walls from excess rain water penetration.

### A.2.6 Dust

All rooms **must** be dust free to protect the pupils and staff from health risks and to prevent distraction.

Existing buildings using mud for walls or mud mortar for roof tiles **must** be sealed to prevent dust.

## A.3 Safe and Secure buildings

All schools building **must** adhere to Rwanda National Building Code.<sup>8</sup> The following are school specific issues which need to be addressed.

#### a. Fire

Spread of fire between rooms

Fire breaks between blocks

Escape route out of building

Outward opening door

Dormitory needs special precaution

Kitchens needs special precautions as a source of fire.

#### b. Wind

Depending on geographical location

Vegetation can be planted as wind breaks.

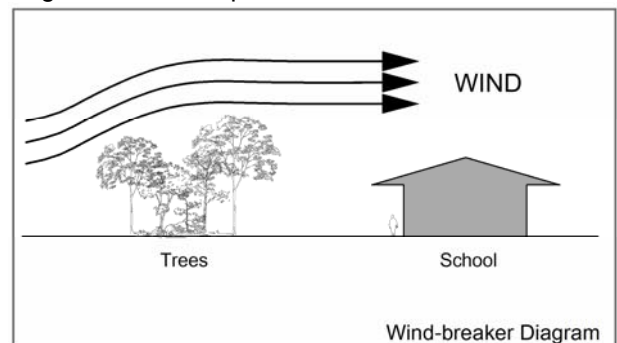

<sup>6</sup> Feed back from staff consultation Musanze 2008

<sup>7</sup> Feed back from pupils consultation 2008

<sup>8</sup> MININFRA

Ensure roof covering, battens, purlins, rafters and roof trusses are securely fixed to main structure to prevent the roofs being blown away.

External fixtures such as external window shutters and external doors are to be securely fixed back to the main structure.

#### c. Earthquake

School building must be safe and resist earthquakes until the occupants reach safe evacuation zones. Northern and Western regions of Rwanda are more prone to earthquakes. However at every school;

- Evacuation drill must be practiced at schools.
- Escape routes to Safe areas must be dedicated.
- Tall furniture must be securely fixed.

For guidance on “Protection of Educational Buildings against Earthquakes can be found on the INEE Inter-Agency Network for Education in Emergency website<sup>9</sup>

#### d. Volcano

Locate schools away from risk areas. (Refer to site selection 2.3)

#### e. Lightning

Buildings in lightning prone areas, lightning conductors should be installed.

### A.3.1 Security

Safety and security is an overarching issue, which **must** be considered in conjunction with requirements for greater community access. Security is as much about creating a feeling of a secure, organised, safe environment, as it is about the specifics of surveillance and supervision of access and protection against risks. Particular attention needs to be given to:

- a.** Access control, for instance to ensure visitors can be shown to an interview room from reception, but cannot enter the school without permission;
- b.** Securing the building ‘**envelope**’ – walls and roofs but particularly windows and doors; security bars may be used to glazed areas.
- c. Clearly** defined site boundaries, using appropriate fencing and/or planting;

---

<sup>9</sup>See website; <http://ineeserver.org/page.asp?pid=1322>

## Standard B

**“A school must be a healthy, clean, secure and learner protecting environment.”**

### Healthy and clean environment

A combination of dirty drinking water, dirty environment and improper disposal of excreta contributes to the degradation of health at schools. A concerted effort to supply safe water, clean sanitation facilities and teach the practice of hand washing with soap will drastically reduce illnesses at schools. This **should** be complemented with teaching to nurture in youths sense of ownership of common goods and their proper operation and maintenance. Refer to Schools Hygiene sub-sector norms and standards.

#### B.1 Water

Water in Rwanda can be collected from many sources including: piped water from spring or a treatment plant, rain water, and open source such as river, stream, and lakes. The annual rainfall cycle varies throughout and within the regions, thus a water management plan needs to be made and implemented. When considering new school sites, availability of clean water access **must** be of the highest priority. (See section 2 site selection).

**Rainwater harvest** systems are encouraged and **should** be used as a method of obtaining water. This will also limit the effect on the environment.

##### B.1.1 Potable water (safe drinking water)

**A school must offer adequate access to safe drinking water.** A minimum of one safe drinking water point **must** be installed at each school together with a hygienic way to drink the water ie availability of water containers and/or cups.

**a. Potable water quantity;** The amount of potable water required for a pupil to remain healthy will depend upon many factors; size of child, climate, cultural and religious practices and activities carried out at school. The table below gives guidance on the minimum amount of water which **should** be available per pupil.

Pupil occupancy at school		Quantity of drinking Water (litres/pupil/day)
Full time pupils	Lunch at school	2 litres /day
	Lunch at home	1 litres /day
Boarding pupils		2.5- 3litres /day

b. Potable water / quality of Safe drinking water.

Safe drinking water **should** be odourless, colourless and tasteless (as per the context). Therefore, its turbidity **should** not exceed 5 NTU. Its conductivity would preferably be equal or less than 2000  $\gamma$ S/cm. If up to 10 fc/100 ml (fc = faecal coliform colonies) are found, a chemical treatment can be performed for disinfection; in this case, the residual chlorine should range from 0.2 to 0.5 mg/l to avoid any recontamination. Other treatments options such as membrane or candle filtration could be considered. Water **should** be exempt from arsenic, fluoride, nitrite/nitrate and heavy metals unless in concentration recommended by WHO for human consumption.<sup>10</sup>

#### B.1.2 Non potable water

**A school must offer adequate access to water for cleaning and washing** at schools with washing points with taps and soap. Minimum 1 washing point per 100 pupils with adequate drainage channels **must** be available.

**a. Non potable water quantity;** The amount of water required for a pupil to retain hygienic level will depend upon many factors such as size of child, climate, cultural and religious washing and cleaning practices carried out at school.

The table below gives guidance on the amount of non-potable water which **should** be available per pupil.

Pupil occupancy at school		Minimum Quantity of non potable Water (litres/pupil/day)
Full time pupils	Lunch at school	10 litres /day
	Lunch at home	7 litres /day
Boarding pupils		20 litres /day

**b. Non potable water Quality;** A clear sign **should** be affixed beside each point to inform users of its non portability. It can contain up to 10 fc/100 ml but **should** preferably be colourless and exempt from suspended solid particles. Otherwise a decantation and clarification can be achieved in a storage tank prior to its use. It **should** be exempt from arsenic and other hard metal unless in quantity prescribed by WHO for human consumption.

#### B.1.3 Water supply systems

Each school **should** have a water storage facility for up to 40 to 60% of the daily children’s water demand. If a municipal network exists, preferably make arrangement to connect the school to it. All connections to the existing mains shall be made with the utmost care using the correct type of

<sup>10</sup> Reference is being made to WHO guidelines for drinking-water quality, 2nd addendum to the 3rd Edition Volume 1- Recommendations.

couplings and note that additional treatment may be required for drinking purpose. The making of these connections shall be planned carefully so as to prevent or limit any disruption or interruption of the existing water supply service to the minimum. The school management **should** also ensure provisions are made to pay for the service unless otherwise regulated by the government for public institutions (free for instance or subsidized).

Otherwise, a borehole can be sunk in school yard or its vicinity and equipped with a manual hand pump. A spring can also be protected (box) and piped to the school. In exceptional circumstances, water can be transported to the school by tanker or rudimentary means (bottles, jerry can or drum in wheelbarrows)

#### B.1.4 Testing water supply systems and the quality of water delivered to children

At least three tests **should** be carried out in each school upon completion of works or/and subsequently once a year: water quality test, leakage and pressure testing. They can all be performed by their respective district engineers. Each pipeline shall be tested progressively for leaks as pipe laying proceeds in suitable lengths not exceeding the distance between adjacent isolating valves. The test pressure shall be twice the normal design pressure and shall be maintained for 3 hours.

Leakage tests shall be carried out only after the pressure test has been satisfactory. The Contractor shall prepare the pipeline section and connections and all necessary appliances for the leakage test. Each test shall be of two hours' duration with the pressure at the normal design pressure. Leakage is defined as the quantity of water that is to be supplied into the pipe so as to maintain the pressure (after air has been expelled).

No pipeline is acceptable if the leakage is more than 2 liters per 50 mm of pipe diameter per 500m length per 24 hours, unless the Engineer decides otherwise.

Physical and biological test can be conducted using a DELAGUA type portable laboratory.

### B.2 Sanitation Facilities (Toilet and hygiene)

The link between poor sanitation and poor health is evident. Also the lack of adequate sanitation facilities is a major reason why many children, particularly girls, fail to attend school. The lack of facilities affects the performance and achievement of all pupils, and is certainly detrimental to the working conditions of teachers.

The role of the child friendly schools is to create learner friendly environments. This is achieved not only through formal classroom education, but also by promoting good practice in daily living and environment. Sanitation is an essential aspect of

promoting good practice and schools have a duty to promote its implementation.

#### B.2.1 Sanitation Facilities Quantity

Appropriate quantity of sanitation facilities **must** be provided according to the ratios in the table below.

Sanitary facility ratio
<b>Girls</b>
30 girls to 1 cubicle Inclusive of 1 girl's accessible/disabled cubicle
1 hand wash point with tap and soap per 2 cubicles
Minimum 1 Hygiene cubicle
<b>Boys</b>
50 boys to 1 cubicle Inclusive of 1 boy's accessible/disabled cubicle 50 boys to 1 metre of urinal
1 hand wash point with tap and soap per 2 cubicles
<b>Staff</b>
25 staff to 1 cubicle with separate Women and Men including 1 accessible cubicle
1 hand wash point with tap and soap per 2 cubicles

a. Girls and boys **must** have equal access to adequate sanitation facilities in schools. (Refer to Standard B.2.1)

b. **Girls and Boys sanitation facilities must be separate** with their own wash basins and taps. The separation must have adequate visual, noise and odour separation.

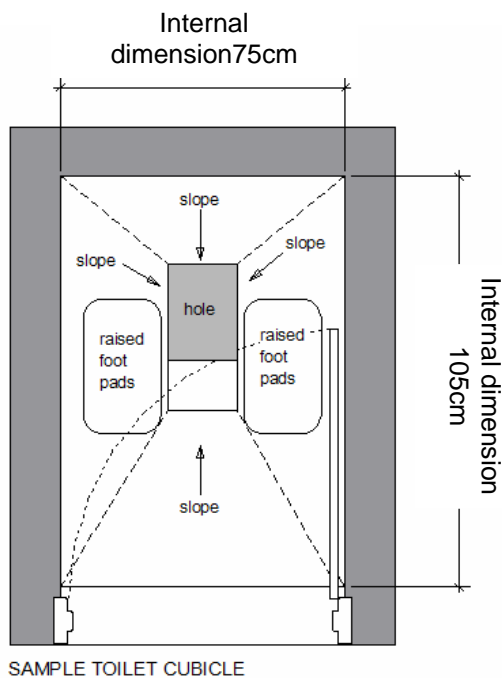

**c. A personal hygiene compartment** where girls are able to wash during menstruation **must** be offered.

**d.** The provision of **sanitary towels, hygienic pads** and disposal facilities **should** be made available at schools for girls in menstruation. Hygienic and safe disposal practice **must** be practiced. Refer to incineration-

**e. Accessible toilets must** be provided. (Refer to Standard C)

**f. Staff toilets** must have separate women and men cubicle with adequate noise privacy.

**d. Cubicle doors**  
The cubicle doors can open inwards or outwards.

Advantages of inwards opening doors are;  
-Privacy, particularly when the door lock is missing or broken.

-Elimination of hazard to those outside the cubicle.

-The doors are hung so that empty cubicles have open doors and are easily found.  
-Inward-opening doors can be designed so that they can be lifted off their hinges **should** access be necessary when someone has fallen against one.

Advantages of outward opening doors are;  
-More space within the cubicle.

Note: Difficulty of reaching anyone locked inside

When intended for use by Muslims the compartment **should** not face in the direction of Mecca, and a low level cold water tap **should** be provided in addition to any flushing water.

## B.2.2 Sanitation Facilities Quality

Sanitation facilities **must** be of appropriate quality.

**a.** All structures **must** be made to a high standard without environmental risks such as unstable floors or full pits.

**b.** All structures and surfaces **must** be constructed to be able to be kept clean and hygienic.

**c.** All sanitation facilities **must** have adequate (natural or artificial) light.

**d.** All sanitation facilities **must** have adequate ventilation.

Cleaning and maintenance practices;

-use smooth durable floor surface which can be cleaned easily.

-consider water and liquid run off directions to avoid pools of stagnant water.

- consider lower height handles for smaller children

- consider smaller holes for smaller children.

## B.2.3 Sanitation Facilities Usage

The sanitation facilities **must** be appropriate for effective usage.

The facilities **must** be located in the right place and designed to account for local customs and cultural sensitivities.

Every WC facility **must** be easily supervised from the class rooms and accessible from out of doors.

The sanitation facilities **must** be clear distance away from class room to avoid smell. Consider wind direction in locating sanitation facilities.

Avoid areas where there is a risk of flooding.

Consider access of maintenance vehicles according to latrine system.

## B.2.4 Technical solutions

Depending upon the schools requirements, site and access conditions, different water and sanitation options **must** be considered to reach the best solutions. Consult a water and sanitation engineer for professional advice.

## B.3 Environmental and Waste management

All types of waste in and around schools **must** be managed by separating biodegradable from non biodegradable wastes and high risk contaminants such as used sanitary towels.



### B.3.1 Composting

Where practical, at least 1 composting facility with two compartments to gather biodegradable material **should** be available.

Composting is the process of decomposing organic material into soil which can be used for enhancing the growths of plants in the school garden.

Materials such as food waste, hay, grass, wood chips, sawdust, weeds, other garden wastes can be put into the compost reducing waste sent to landfills. Additionally, pupils can learn first hand how organic cycle works. Additionally, the facility can be incorporated into the science curriculum.

**Location;** Compost should be located at convenient distance from the main source and final use. Example; located between kitchen and garden and away from main pathways.

**Below ground:** Two pits are needed so that each can be aerated and used alternately. Each pit has a total depth of 1m deep according to each school's needs.

Pits for composting **must be** built on permeable soil in order to allow surface water to seep through easily. If this is not taken into account, ponds of water mixed with compost materials might flood the nearby surrounding after heavy rain showers.

**Above ground:** Well ventilated containers, and make sure that the compost is always moist.

### B.3.2 Incinerator

An incinerator (in accordance to district, city planning policy) **should** be available within the school grounds. High risk contaminants such as used sanitary towels must be disposed safely.

Its location in the school yard **should** allow it to be operated without interfering with the normal course of classes due to the smoke it might produce. Despite orientating it with due consideration to prevailing winds, its chimney **should** be at a height above the roof of the closest classes.

Alternatively, consider an open pit which should be filled up after use.

### B.3.3 Stagnant water

Stagnant water within the vicinity of the schools is discouraged. Pools of stagnant water often become breeding grounds of vectors such as mosquitoes which can increase the disease transmission such as malaria.

To avoid stagnant water adequate drainage system **must** be put in place as dictated by the land contours.

All external drainage and storm water **must** be channelled and led away from the school grounds. The surface run-off should be led away through

natural slopes on the site or through drainage channels laid in bricks or concrete. It is encouraged to use the drainage waters to irrigate the school gardens or channelled into a soak away pit.

The drainage channels must not create obstacles or trip hazards in pathways.

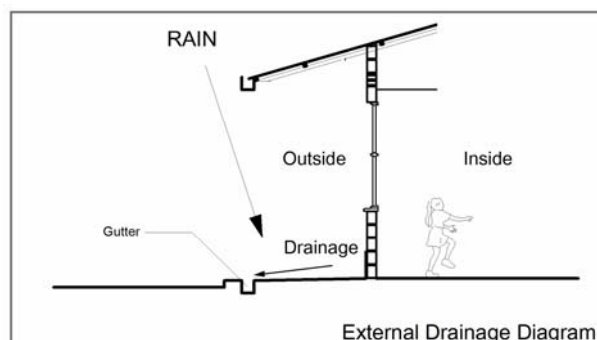

Diagram illustrating "Drainage allowance away from the building"

## B.4 Secure and learner protecting environment

### B.4.1 Passive surveillance against harassment and abuse

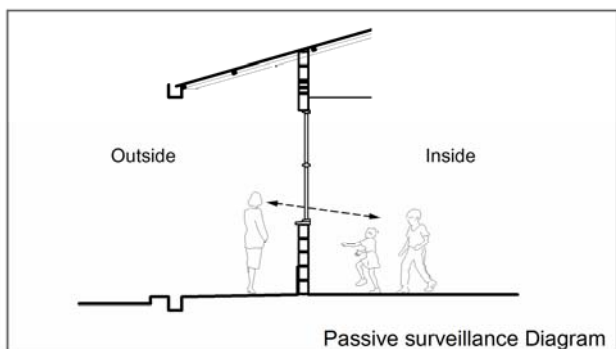

Diagram illustrating  
"Clear visual contact from the outside into the rooms"

All spaces in educational institutions; including class rooms, administrative offices and store rooms **must** have passive surveillance to ensure protection of girls, boys, children with special needs and women from physical abuse, sexual harassment and unwanted sexual advances. A good visual connection into each room from the outside at all times is essential. This can be achieved by glazed windows without wooden shutters as diagram above.

### B.4.2 Fences

1.5 m high fences **must** be erected along the entire perimeter of the school grounds to;

- a. Demarcate the school grounds.
- b. To prevent theft and destruction of school property.
- c. To prevent children from leaving the school ground unattended.

The fence may be of various materials.

**a. Galvanized chain link mesh** 1.5m high with three galvanized line wires. Straining posts and struts of reinforced concrete (or 50mm galvanized pipe) with appropriate top covers shall be bedded in appropriate quality concrete. The straining posts shall be at intervals not exceeding 3m.

**b. Vegetation** local trees, plants and flowers (euphorbia, bougainvilleas) can be planted.

**c. Mud walls**

## Standard C

**“A school must have a child-friendly, barrier free environment which promotes inclusive access and equal rights of every child.”**

### C.1 Child-Friendly environment

The school environment, as a child-friendly one, **must** provide the basis for mental and physical development of children, meaning that the facilities are the social setting for child interaction as much as a formal learning environment.

This is reached through a conscious mix of the Child Friendly Schools concepts to create a secure and comfortable learning place for all pupils and staff.

A Child Friendly School **should** serve children of different age groups. Needs and activities in each group vary and physical spaces need to be arranged to fit their specific development stages

Nevertheless the activities and contacts between groups **should** be integrated as much as possible to the normal school, as interaction between groups and genders can help to break cultural conventions and practices.

The environment **should** consider age groups and make the learning environment fit to their physical size and stage in development.

### C.2 Barrier Free environment

A school **must** ensure that the facilities are reasonably accessible and usable to all, regardless of age, gender and any special needs. The built environment **should** encourage the integration of all pupils into the same learning environment and teaching.

Specific adjustments for learners with special needs **must** be considered in school design.

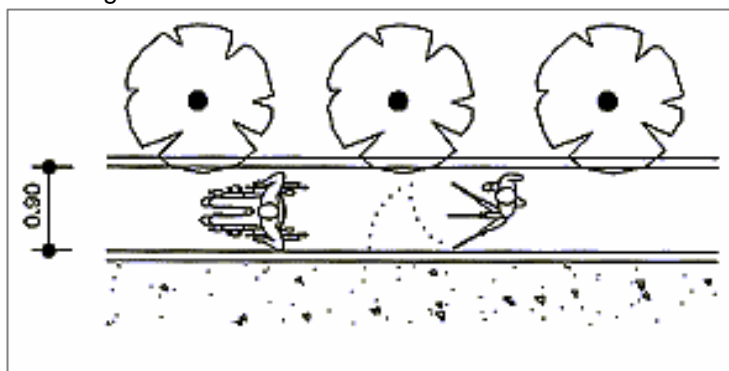

The school **should** either:

- a. consider special facilities
- b. consider adaptable facilities
- c. consider adapting existing facilities which cater for the special needs.

Some of the more common impairments may be categorised as the follows:

<b>Impairment</b> <sup>11</sup>	Wheel chair users
	Partially impaired, (temporarily impaired)
<b>Visual Impairment</b>	Blindness
	Low vision
	Albino
<b>Hearing</b>	Hard of hearing or deaf
	Speech Impairment

#### C.2.1 Access

A school **must** allow reasonable access to all (pupils, visitors and staff) into the learning environment.

All users including visitors, pupils and staff **must** be able to:

- a. Gain access to and within the educational facilities.
- b. Use sanitary conveniences
- c. Walkways and doors **must** be a minimum of 900mm wide for a wheelchair to pass as per diagram below.

<sup>11</sup> Physical impairment: all the people having a impairment limiting their mobility and their capacity to handle items.

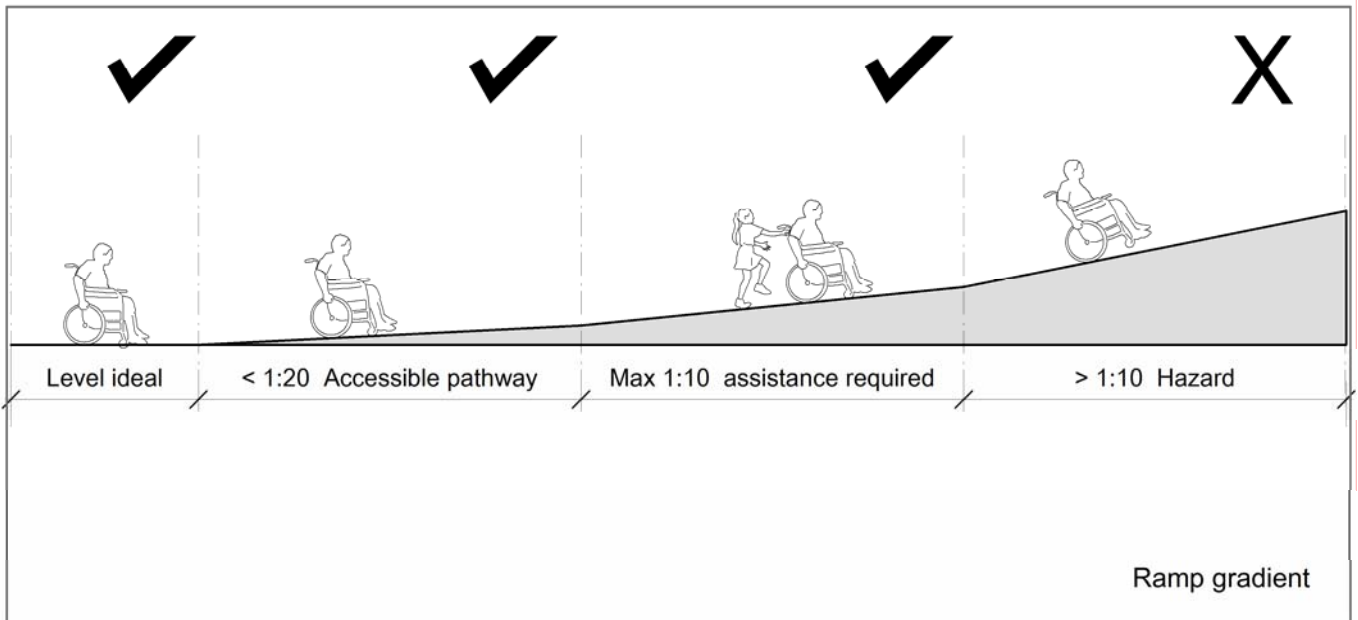

d. Any thresholds (level changes at the door) **must** not be more than 13mm high.

e. Floor surfaces **must** be firm, durable, slip resistant and smooth.

f. The difference in level at joints between paving units is no greater than 5mm, with joints filled flush.

### C.2.2 Ramps

Where there is a change in level, a ramp **must** be provided at 1:20 gradient and a maximum 1:10 gradient when assistance is available (refer to ramp gradient diagram) where possible it is beneficial to have steps as well as a ramp.

Note: Ramps are not necessarily safe and convenient for ambulant disabled people. For example, some people who can walk but have restricted mobility find it more difficult to negotiate a ramp than a stair. In addition, adverse weather conditions increase the risk of slipping on a ramp.

a. In conditions where both ramp and stairs are provided; the ramp **should** have a minimum 900mm width with 900mm width steps.

b. The ramp surface **must** be slip resistant, especially when wet.

c. There **must** be a landing at the foot and head of the ramp at least 1.2m long and clear of any door swings or other obstructions.

d. there **must** be a handrail on one side of the ramp at 800mm above finished floor level. Alternatively, there **may** be two handrails at different levels to accommodate different height users i.e. children.  
- One at 600mm and another at 900mm

### C.2.3 Accessible toilets and hygiene facilities

Schools **must** make the provision of a minimum one wheelchair-accessible toilet per sex per school. Wheelchair users **must** be able to **approach, enter, transfer to, and use sanitary facilities** provided within the school grounds.

The dimensions of the accessible toilet **must** be as per accessible toilet diagram below.

a. **Approach;** The accessible toilet **must** have a wheelchair-accessible route to and from the toilet, if necessary with ramps.

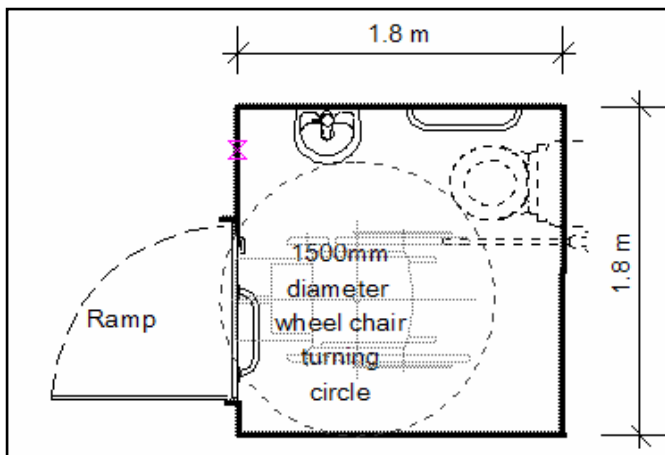

Accessible Toilet Plan

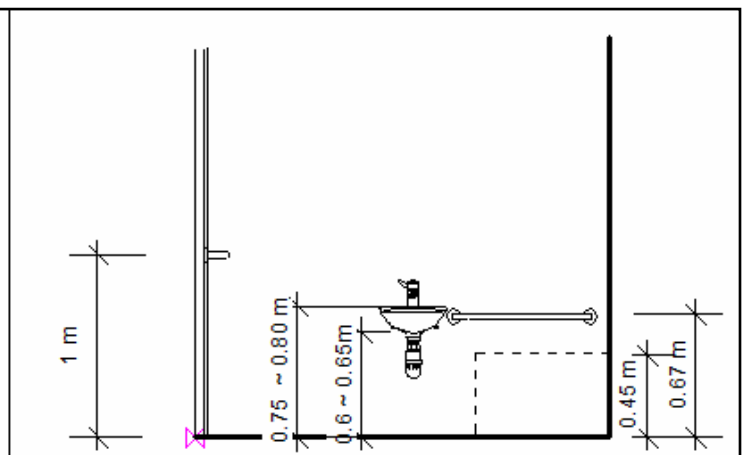

Mounting heights

**b. Enter;** The user **must** be able to be open and close the door independently. The door **must** be outward opening with a pull close handle to the inside of the door, allowing enough manoeuvring space for the wheelchair user to turn.

**c. Transfer;** The space provided for manoeuvring, **should** enable wheelchair users to adopt various transfer techniques that allow independent or assisted use. When transferring to and from their wheelchair people require horizontal support rails as to diagram.

**d. WC pan;** The WC seat height **should** be 480mm above finished floor level.

This **may** be achieved by :

- a ceramic toilet pan (propriety) with push flush
- a custom made seat according on sanitation strategy

**e. Finger rinse basin;** The user **should** be allowed to wash hands while seated on the WC.

### C.2.4 Classrooms

Classrooms **must** be large enough to allow for movement by disabled pupils which means that pupil using a wheelchair **may** access all areas of the room. Therefore participate in all activities equally, without any disruption to classroom layouts. (Refer to class room standard A and D)

### C.2.5 Signage

Clear signage is essential for the partially sighted people.

**a.** Visual signage **should** be used to aid people with special needs.

**b.** The sign **should** be situated on corridor walls next to doorways 1350 mm high mounted on the side of the handle when the door is closed to identify the room.

**c.** The signage **should** have colour and tonal contrast to the background.

**d.** Signage **may** include brail plaques.

### C.2.6 Tactile surfaces

The flooring **should** be used to indicate the route from the school entrance to each room and sanitary facilities. Tactile surfaces **should** also indicate change in levels such as at the beginning and end of steps, stairs and ramps. These tactile surfaces **should** be 5mm above the main surface. This **may** be achieved through casting smooth stones in concrete walk ways or imprinting differential textures on the surface.

### C.2.7 Special Needs Rooms

Appropriate space for pupil support whether educational, therapeutic, psycho-social or medical care **must** be provided close to Staff room or connected to a class room. The categories of pupils which need special attention are categorized in section C.3. The integration of pupils with special needs into the class room activities is normally encouraged. However there are instances where it becomes beneficial for a teacher to devote special attention to these groups.

#### Range SEN rooms which are useful.

**a.** A multi-purpose, small-group room for specialist teaching and pupil support.

**b.** A medical and therapy room for pupils and staff.

**c.** An interview room next to the entrance or directors room that can be used by parents, carers, and social service.

**d.** Small annex room attached to the class room where pupils with special needs can time to time work independently.

**e.** Storage space for educational and mobility equipment.

### C.3 Equal access

Highlighted in the “Education for all” policy paper, which states that inclusive education systems are the key to reaching out to all of those who are excluded within and from education.

To promote equal access to all children is to address any discrimination which may be an obstacle to gain access to education opportunities such as; poverty, age, geographical location linguistic, cultural and social marginalization, disabilities and HIV-AIDS.

As a reference the following list highlights categories of vulnerable children according to international guidelines:

#### Categories learners with Special Educational Needs<sup>12</sup> (SEN)

Abused children
Refugees or displaced children
Child labourers
Migrants
Religious Minorities
Poverty-stricken children
Child domestic workers
Language minorities
Street children
Children in conflict zones/child soldiers
Children with disabilities
Nomadic children
HIV/AIDS orphans

<sup>12</sup> Source: Inclusion Guidelines (UNESCO, 2005, p.11)

For the common types of impairments, standards outlined in clause C.2 are essential for their equal participation in the school.

### C.3.2 Specific Religious needs

Specific religious needs **should** be respected and catered for within the school environment.

For example Muslims require water sources to wash before and after prayers, and also requires water at the latrines.

### C.3.3 Gender Balance

Rwanda has made significant progress in relation to the Millennium Development Goals related to universal primary education and gender parity in education.

In 2008 the Net Enrolment Rate (NER) was 95.8% however, **access and retention** remains a challenge.

**Achievement** - 52% of children complete their primary education (37,91% of girls and 62,09% of boys in 2006)<sup>13</sup> and only 55.3% of girls progress to secondary school compared with 62% of boys and; 31,7 % girls passed Tronc Commun exams in 2006 while 68,3% of boys passed.<sup>14</sup> The situation becomes even worse at tertiary level where only 26% of the undergraduates are women.<sup>15</sup>

The various stakeholders involved in supporting girl's participation in schools need to be aware of existing cultural taboos and beliefs around puberty, and the related implications in terms of girl's sanitary practices.

A deeper understanding of girl's daily struggles, and rationale behind proposed solutions, is essential to engaging policy makers who can enact legislation and make resources available at a national level.

Aside from any discussion of the environmental, cultural or other issues connected to menstrual protection choices, girls need menstrual material that will enable them to sit and move around comfortably in a classroom for several hours in a row.

Developing and implementing sustainable and empowering solutions for girl-centred sanitation requires (refer to standard B) holistic approaches and is far more than an engineering challenge. It has to involve teachers, school administrators, engineers and community workers to provide a learning environment that is responsive to girl's needs. This implies safe, appropriate sanitation facilities, as well as learning opportunities about

puberty-related body changes. Above all, ideas for areas of improvement must come from young people themselves.

#### C.3.3.1 Gender allowance in infrastructure

In terms of infrastructure any improvements which support for both girls and boys to take advantage of all opportunities is encouraged.

**a.** Girls and boys **must** have equal access to adequate sanitation facilities in schools. (Refer to Standard B.2.1)

**b.** Provision of playgrounds **must** ensure both boys and girls can freely participate in games and sports. If girls' specific games are practiced, schools **must** allocate specific areas for the activity within the school grounds.

<sup>13</sup> MINEDUC Girl's Education Policy, 2008.

<sup>14</sup> MINEDUC Tronc Commun results, 2006.

<sup>15</sup> MINEDUC, 2002.

## Standard D

**“A school must have adequate and appropriate equipment that support the level of education.”**

### D.1 Furniture

The correct school furniture will enable the efficient functioning of activities within the school.

The following table outlines the furniture which are suggested which each school must choose accordingly to be in each room type.

Room	Furniture
Class room	Pupils desks chairs
	Teachers work station with lockable drawer and chair
	Display surfaces 7m <sup>2</sup> of wall space
	Chalk boards minimum 5.5m <sup>2</sup> preferably on two walls where there is good illumination. Chalk board <b>must</b> be painted regularly to ensure clear vision
	Cupboards or shelves for books IN earthquake prone zone, shelves <b>should</b> be low level and securely fixed
	Coat hangers easy access to coats and bags, if the school's policy is to store them in the classroom
Head teacher's room	A desk, a chair, cupboard/shelves, waste bin, visitors' seats and a meeting table
Staff room / teacher resource room	Cupboards/shelves, tables, chairs and waste bin
	Computer, printer and a photocopying machine
School Grounds	Signage, Waste bins, notice boards, external furniture
Storage space	Shelving
ICT room	Desktop computers, printers, tables and chairs
Library / learning resource area	Computer printer TV & DVD player, copier, LCD projector, shelves, tables, and chairs
Medical sick room	Examination/resting bed, first aid kit, chair
Special needs room	Desk and chairs, specialised equipment.
Sanitation facilities	Girls sanitary bin, sanitary towels, toilet paper (according to the costume), soap

### D.1.1 Class room furniture design

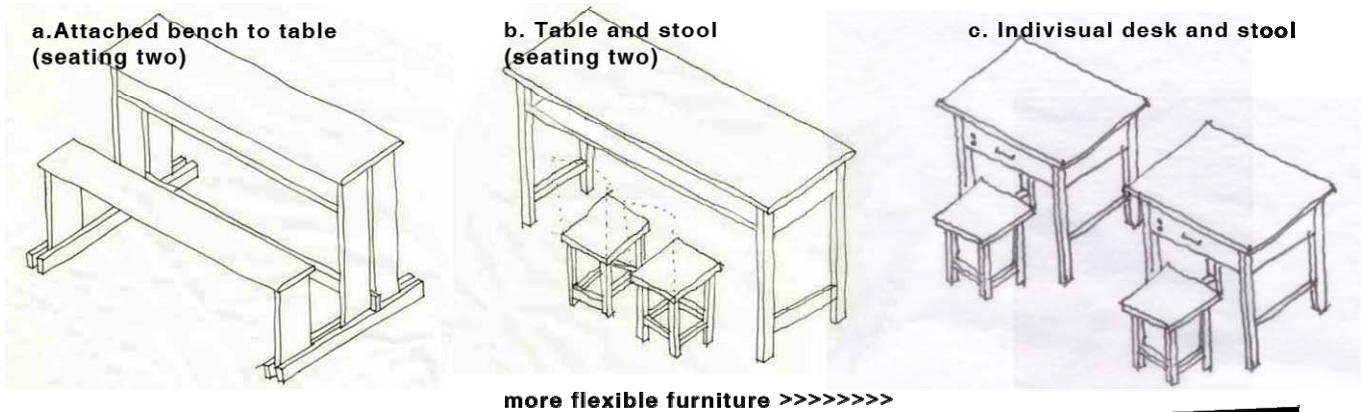

#### Class room furniture

Each class room must have tables and chairs, they are a basic necessity for every pupil to learn effectively. There are three basic designs available for consideration by each school depending upon their teaching style and budget. Furniture that allows flexible teaching methods and classroom layouts are encouraged.

a. Attached bench to table; This option has been the traditional school furniture. This type seats two pupils however, many over crowded classes seats up to four pupils. This design has its limits that it is easily damaged when moved around in the class room.

b. Table and stool; This option of a table for two pupils and two detached stools or chairs gives more privacy to the pupils as they can be separated esp. during exam periods. The seat can be stools or chairs according to the available space in the class room and budget.

c. Separate desk for each pupil; This option gives the greatest flexibility in arranging the class room. At the same time it gives the pupil the ownership of the desk supporting the pedagogy of looking after their own property.

#### Class room furniture size

It **must** be ensured that the furniture provided is of compatible heights and suitable for use by pupils.

Different size of chairs and desks **should** be used for different sizes of pupils. Below are the three furniture sizes according to age groups categories.

Furniture size	Small	Medium	Large
Level	P1-P3	P4-P6	P7-P9
Age	7,8,9	10,11,12	13,14,15

The school **should**, when there is a need, provide adapted furniture, table and chair, for pupils with special needs.

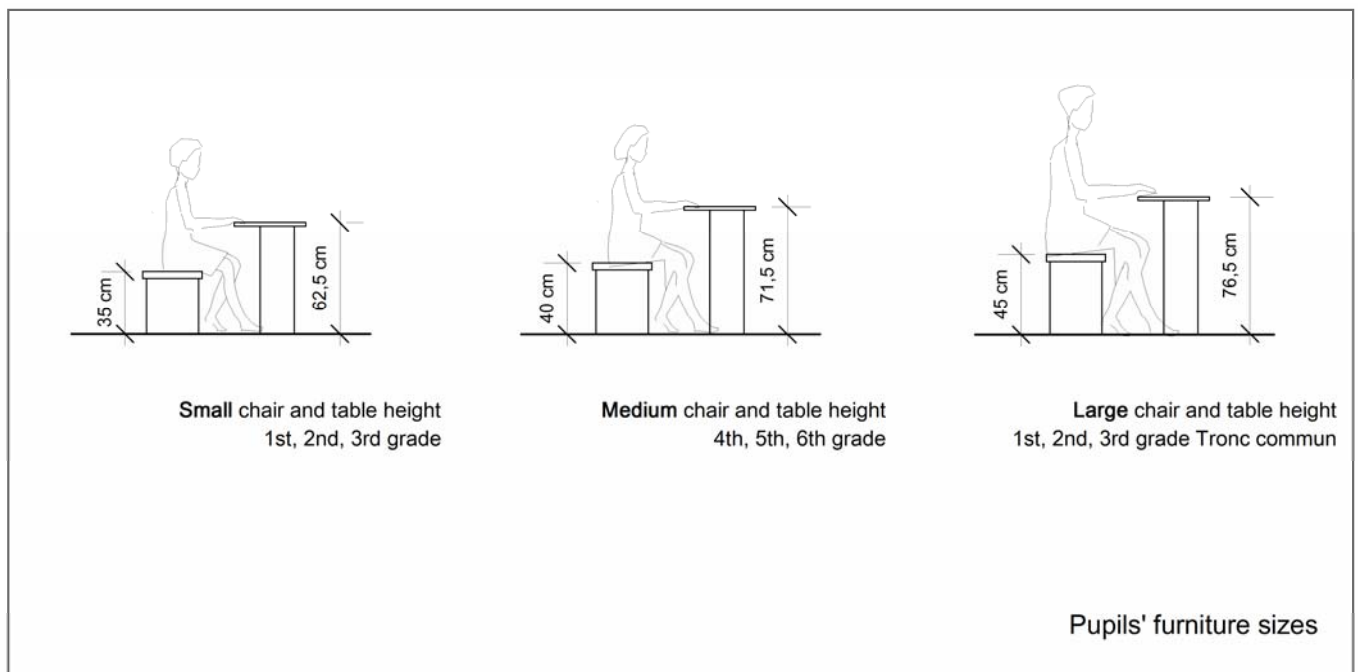



### D.1.2 Class room layout

The class room layout must allow effective supervision and allow for interactive teaching by consider the following;

- a. Adequate space to enter the room and to allow good circulation around the room and between furniture, this should take into account the needs of pupils with disabilities.
- b. Furniture layout in the classroom should secure good sightlines for a range of activities, especially between teacher, pupils and chalk-board or similar.
- c. Two sides of the classroom should have a chalkboard to allow flexibility within the space. Storage, such as shelves should be arranged in suitable heights.
- d. Teachers platform The installment of a teacher's platform has been customary. However this limits flexible room layout and alternative teaching methods, also prevents wheelchair users

approaching the chalk board, thus these platforms are now discouraged.

The following furniture layout plans shows three different ways in which a class can be organized. The ability to alter the layout easily will depend upon the type of furniture as described in page 33.

#### Option 1 Traditional front direction furniture layout plan

This arrangement is where the tables are placed in rows facing the chalk board to the front.

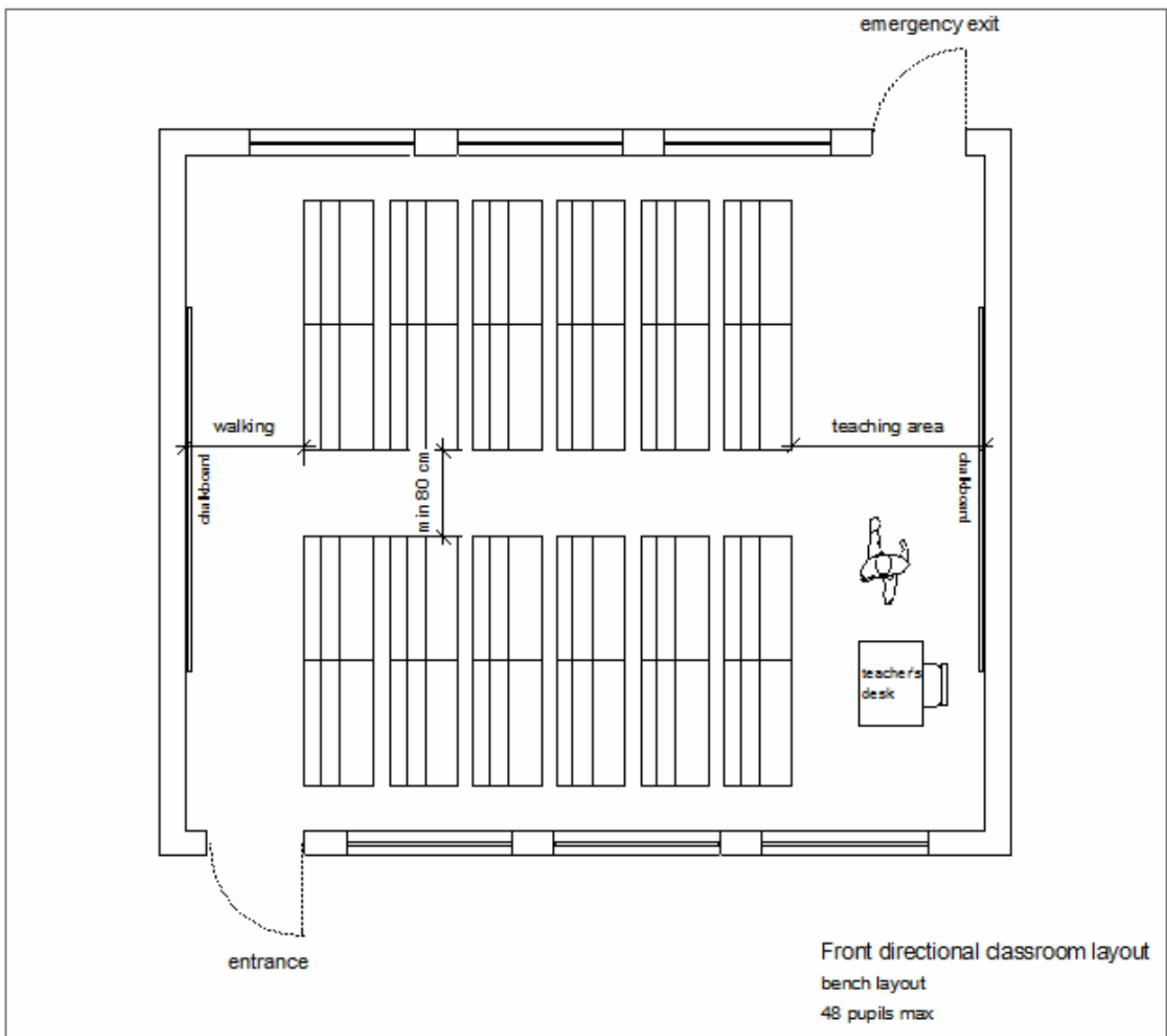

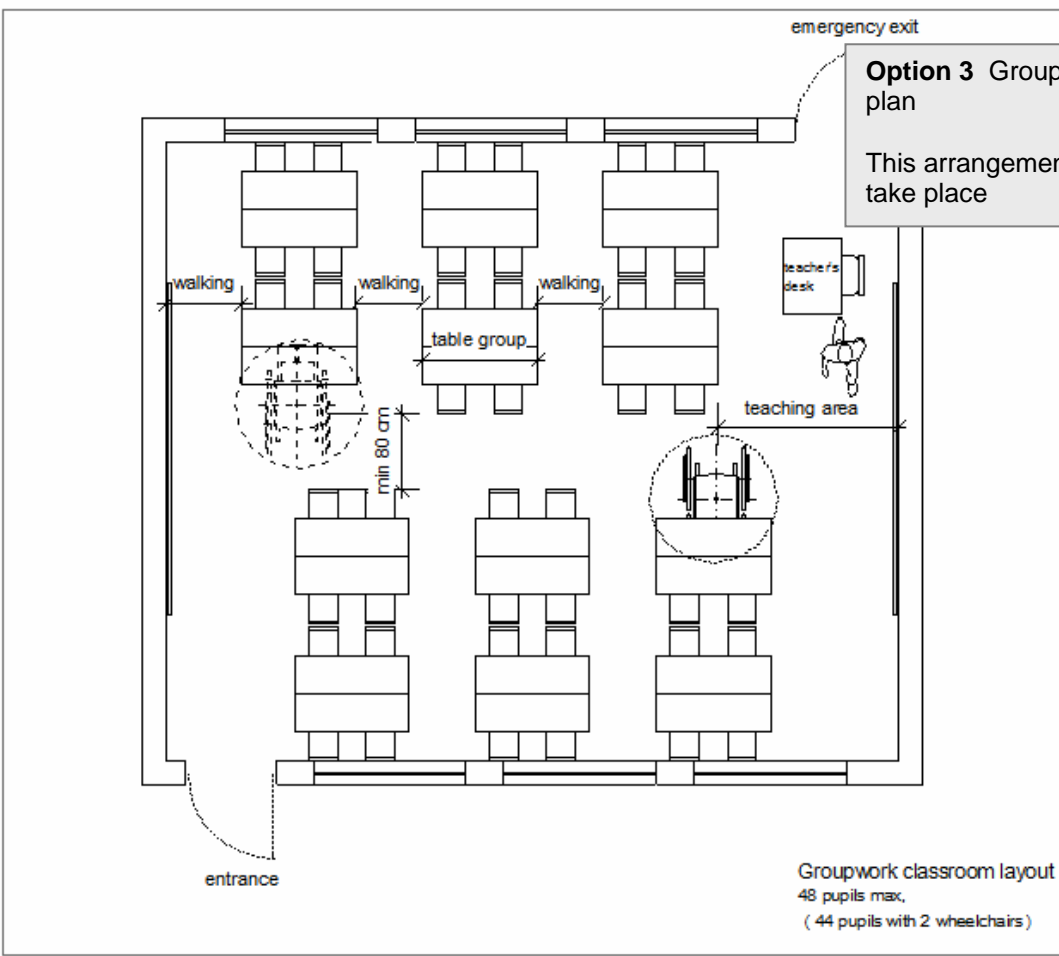
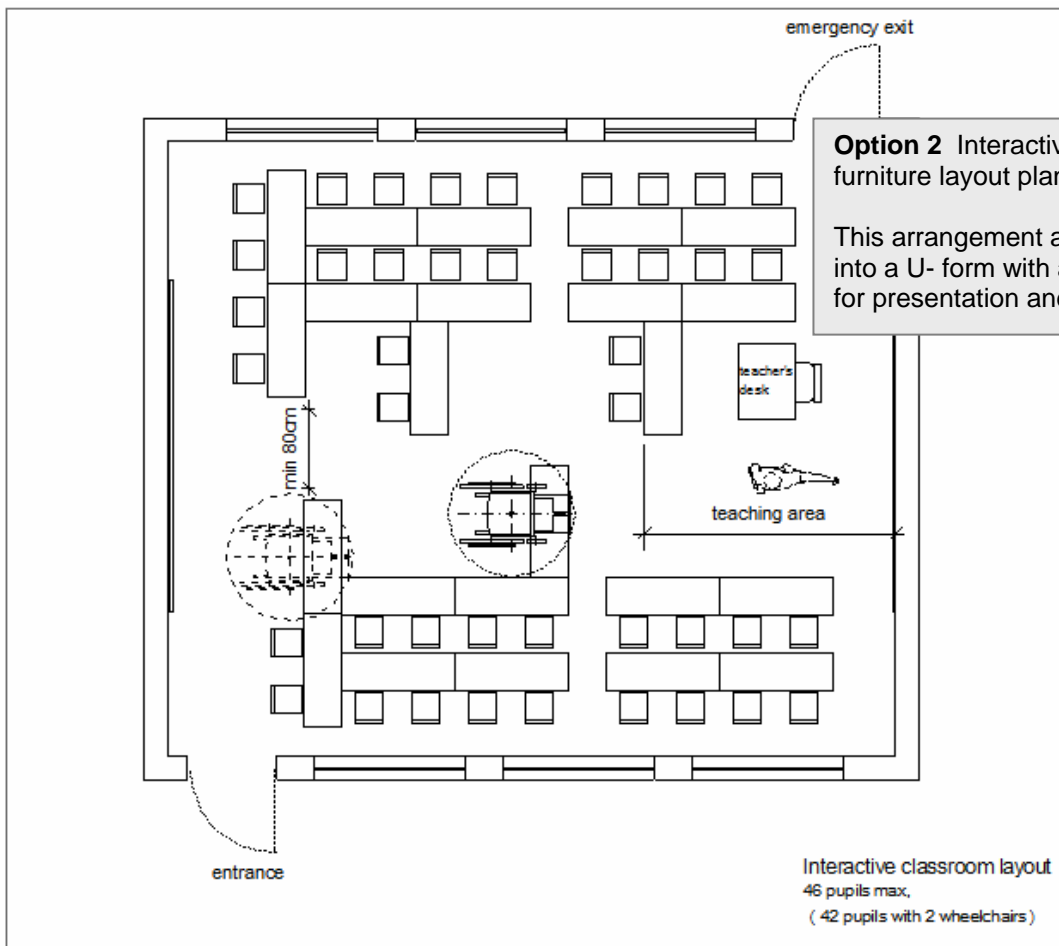

## D.2 Equipment list

A school must have adequate equipment and material to operate a successful teaching and learning environment. Each school **must** have

- First Aid kit
- Sanitary material
- Didactic material
- Sports equipment

The following is a list of common equipments required. The list is a reference / a shopping list which can be used to ensure correct equipment are available according specifically to each school.

All equipment **must** be stored away safely, maintained and kept clean and complete for the intended use by the school management.

	N o.	Kit contents/Description:
<b>First Aid kit</b>	1	Gloves, exam, latex, medium, disp /BOX-100
	2	Tape, adhesive, Z.O., 2.5 cm x 5 m
	1	Tape, adhesive, Z.O, perforated, 10 cm x 5 m
	2	Bandage, elastic, 7.5 cm x 5 m, roll
	10	Bandage, gauze, 8 cm x 4 m, roll
	1	First Aid bag, 410 x 280 x 170mm
	1	Compress, gauze, 10 x 10 cm, n/ster, /PAC-100
	1	Compress, paraffin, 10 x 10 cm, ster, /BOX-10
	10	Compress, gauze, 10 x 10 cm, ster. /PAC-5
	1	Pin, safety, medium size, /PAC-12
	1	Soap, toilet,bar, approx.110 g, wrapped
	1	Blanket, survival, 220 x 140 cm
	1	Towel, huck, 430 x 500 mm
	1	Forceps, dressing, standard, 155 mm, str
	1	Forceps, artery, 140 mm, str
	5	Scalpel blade, ster, disp, no.22
	1	Scissors, 140 mm, str, s/b
	1	Ibuprofen 200mg tabs/PAC-100
	1	Tetracycline eye ointment 1% /TBE-5 g
	1	Chlorhexidine conc. sol. 5% /BOT-100 ml

<b>Sanitary material</b>	
	General cleaning equipment
	General cleaning products
	Hand washing soap
	Girls sanitary towels
	Girls sanitary bin in each cubicle

<b>Didactic material</b>	
<b>General</b>	Ruler, for chalkboard 100cm
	Triangle chalkboard, 30-60-90 degrees 60cm
	Triangle for chalkboard, 90-45 degrees 60cm
	Protractor for chalkboard 180 degrees 44cm
	Compass for chalk board 40cm
	Al purpose Scissors 18cm
<b>Metric</b>	Weigh / balance
	Weights with a range from 1g to 500g
	Measuring tape
	Volume measure 1litre, 1/2litre, ¼ litre plastic non deformable container
	Decimetre cube
	Series of solids cube prism cone cylinder

<b>Geography kit</b>	Globe
	Colour Map of Rwanda, laminated 70x100cm
	Colour map of Africa laminated 70x100cm
	Colour map of the World laminated 138x98cm
<b>Science set</b>	Small chemistry set
	Small electricity set
	Chemical kits
	Micro burette
	Manual in French and English
	Microbiology video cassette english
	Microbiology video cassette french

<b>Sports equipment</b>		
<b>Play</b>	Hula hoops assorted colours	
	Frisbee, polyethylene, 20cm diameter	
	Skipping rope polyester 3m	
	Tabards, red nylon mesh	
	Ball, sponge rubber,60-80mm diam	
<b>Basketball</b>	Basketball, professional size	
	Basketball post	
	Basketball net	
<b>Football</b>	Football, round, junior, synthetic leather	
	Foot ball goal	
	Foot ball net	
<b>Handball</b>	Football, round, professional	
	Handball junior, synthetic leather	
	Handball senior, synthetic leather	
	Handball goal	
<b>Netball</b>	Handball net	
	Netball, round, synthetic	
<b>Netball</b>	Posts and net for netball	
	Volleyball, professional model	
	Net for volleyball 9.5mx1m	
<b>Volleyball</b>	Posts for volleyball	
	Table tennis table	
	Table tennis ball	
<b>Table Tennis</b>	Table tennis bat	
	Table tennis net	
	Javelin men's 800gr	
	Javelin women's 600gr	
<b>Athletics</b>	Discus mens 2kg	
	Discus women 1kg	
	Shot put mens 5kg	
	Shot put womens 4kg	
	Poles and bar for high jump	
	Mattress 4x5m	
	Poles and bar for pole vault	
	Baton	
	Starting blocks	
	Stop watch	
	<b>General kit</b>	Tape measure, 50m, retractable
		Picket with flag
		Inflating-kit for balls
Whistle, referee's non-metallic		

## Bibliography

Sanitation for Primary Schools in Africa Bob Reed and Rod Shaw Water, Engineering and Development Centre Loughborough University

Sphere standards 2004

UK building regulations  
"School Building programme

Building Bulletin, BB98, Briefing Framework for Secondary School Projects, UK

Building Bulletin, BB99, Briefing Framework for Primary School Projects, UK

Design Manual" Eastern Cape Dept of Education

"Criteria and standards for child-friendly schools"  
UNICEF Iraq 2006  
Standards for improving education quality in Rwanda, presented by  
Narcisse Musabeyezu  
Inspector General of Education

British Standard, BS 6465-1:2006  
Sanitary installations –Part 1:  
Code of practice for the design of  
sanitary facilities and scales of provision of sanitary  
and associated appliances, 2006

Sport for Education and Unity in Rwanda, UNICEF

Playing the game – the positive power of sports and  
development in education in Rwanda, UNICEF

Space planning Norms and Standards for public  
schools, Dec. 2007  
KwaZulu –natal Department of Education, South  
Africa

Standards for Improving Education Quality in  
Rwanda, MINEDUC, 2008

Technical Brief for Watsan, TB 1, OXFAM

Sanitation for Primary Schools in Africa, WEDC  
2008

Education in Emergencies, Save the Children, UK,  
2003

Human Development Report 2007/2008, UNDP

School Building Programme, Design Manual, Draft  
Edition, South Africa

International Building Code, 2006, International  
Code Council

School Building's in developing countries, Practical  
Action

Educational Building Report 13, 1987, UNESCO

Building with earth in Auroville, India

An international resource for early childhood,  
Coordinators'

"Child Friendly Schools for Thailand" Thai Ministry  
of education UNICEF 2008

"International Building code" International code  
council 2006

"Metric Handbook" 2006

"Minimum standards for Education in emergencies,  
chronic Crises and early reconstruction" Inter-  
agency Network for Education in emergencies  
(INEE) 2006

"Linking pedagogy and space" Department of  
education and training (Victoria 2005)

Malawi School Project, John McAslan + Partners  
with Arup, 2008