

For Arid Zones

Building hygienic and  
earthquake-resistant  
**ADOBE HOUSES** using  
Geomesh Reinforcement

Julio Vargas-Neumann  
Daniel Torrealva  
Marcial Blondet



PONTIFICIA UNIVERSIDAD CATÓLICA DEL PERÚ. 90 AÑOS



**Requirements for geomesh reinforcement for adobe construction:**

The geomesh must have linked knots and 5-centimeter (maximum) wide openings, as well as the flexibility and durability required for effective use as reinforcement of earthen structures.

The geomesh can be used as reinforcement for adobe buildings. It should be placed on both faces of all walls (bearing and non-bearing). It should be held in place by plastic strings separated by no more than 30 centimeters.

The geomesh must be used at the edges of all doors and windows and must be securely attached to both the foundation and the collar beam of the structure.

The geomesh must be covered by a mud plaster.

APROVED BY THE MINISTRY OF HOUSING, SANITATION AND CONSTRUCTION ON  
NOVEMBER 27, 2007

For Arid Zones

Building hygienic and  
earthquake-resistant  
**ADOBE HOUSES** using  
Geomesh Reinforcement

Julio Vargas-Neumann  
Daniel Torrealva  
Marcial Blondet



**FONDO  
EDITORIAL**

PONTIFICIA UNIVERSIDAD CATÓLICA DEL PERÚ. 90 AÑOS

First edition: December 2007

Building hygienic and earthquake-resistant adobe houses using geomesh  
reinforcement  
For Arid Zones

© Julio Vargas Neumann, Daniel Torrealva and Marcial Blondet, 2007

© Pontificia Universidad Católica del Perú, 2007

Av. Universitaria 1801, San Miguel, Lima

Phone: (0051 1) 626-2000

E-mail: [feditor@pucp.edu.pe](mailto:feditor@pucp.edu.pe)

Translated by Jimena Ledgard

This publication may be reproduced partially or in full as long as the source is fully  
acknowledged

National Library Legal Deposit number 2007/12444

Printed in Peru

## Acknowledgments

The Rector of the Pontifical Catholic University of Peru (PUCP) commissioned Julio Vargas to develop this manual, which includes proposals for the construction of safe and hygienic adobe dwellings.

The proposal for reinforcement of adobe buildings using geomesh (or geogrid), initially conceived by Daniel Torrealva, was developed by the Catholic University through research projects that were directed by Professors Daniel Torrealva, Marcial Blondet and Julio Vargas-Neumann, Professors of Civil Engineering at that Institution. Care-Peru participated in the design of the housing models, and contributed the sanitation solutions and the guidelines on how to make a better and improved family stove.

This booklet is the outcome of a long and committed effort by many institutions and individuals who worked together to improve the quality of adobe construction. The writers of this manual would like to thank them, for this project wouldn't have come together without their help and contributions.

We acknowledge the contributions of the following:

- o Professors Francisco Ginocchio and Gladys Villa-Garcia, who have accompanied us in this task, with strong dedication and enthusiasm.
- o The teachers, students and lab personnel that took part in the research projects.
- o The PUCP's Academic Research Director's Office, for their financial support of the research carried out for this project.
- o The Social Responsibility Director's Office, leader of the institutional efforts to contribute to the reconstruction of the area affected by the earthquake of August 2007.
- o Care-Peru that, along with the PUCP, develops and executes training programs on secure adobe construction.
- o SENCICO<sup>1</sup>, along with all the dedicated Peruvian professionals involved in this project, for developing the National Building Regulations that legalize adobe construction.

---

<sup>1</sup> SENCICO - governmental organization dedicated to the education, improvement and certification of construction workers across the country and to the improvement of national construction standards.

- o The professionals who worked to develop the housing models presented in this booklet: the architects from Forsur<sup>2</sup>, PUCP and Ica's San Luis Gonzaga University.

Finally, we would like to thank USAID, GTZ, CIID and GCI, the international institutions that collaborated in several and important research programs.

## **THE AUTHORS**

**Lima, December 2007**

---

<sup>2</sup> Forsur – Earthquake Reconstruction Fund

## Contents

1. Building my home	8
Coastal zone dwelling plan	9
Coastal zone finished dwelling	10
2. Necessary materials to make adobe bricks	11
Adobe mold	11
Necessary tools to construct an adobe building	11
3. Finding the right soil	12
How to test if the soil from a quarry has the right amount of clay	12
Adobe mud preparation	13
How to fill a mold without bottom lid	14
How and where to dry the adobes	16
How to make test adobes	17
4. Building my home's foundations	18
Outline and excavation	18
How to make the foundations	19
How to prepare the mixture	19
How to build the plinth walls	20
How to place the wall reinforcement	21
5. Building my home's walls	23
How to build a narrow lean concrete base	25
How to make the collar beam	27
How to set the geomesh in place	28
How to cut the grid around the doors and windows	29
6. Roof construction	30
How to make the roof's truss	30
Roof's truss details (1)	31
Roof's truss details (2)	32
How to set the beams, cane, mats and mud in place	33
7. Finishing the walls	34
How to plaster the walls	34
How to apply the mud coating on the mesh	35
How to polish the walls	36
8. Making a better family stove	37
What do we need to improve our family stove?	37
How to make a better stove	38
9. Ventilated dry latrine	39
How to make the latrine	39
Use and maintenance of the latrine	40

This booklet will explain to you, step by step and in simple terms, the basic concepts and techniques you will need to know to construct a secure and earthquake-resistant house using geomesh-reinforced adobe.

This manual was designed and developed for our fellow citizens of Peru in the area affected by the earthquake of August 15, 2007.

## **1. Building my home**

Remember to assess all the possible dangers that could be present in your land before building your home.

Do not build in land that is at risk of sinkholes, water-borne sediments, landslides or floods.

Do not build in filled land, loose sandy soils, wind-carried sediments, soft soils, organic soils, clay soils, soils that are unstable to water or expansive soils.

Do not build in soils with a shallow groundwater table. The behavior shown by this type of soil during seismic activity can be dangerous and inconvenient for construction.



## Coastal zone dwelling plan

Patio and kitchen (covered by a shelter of thatch)

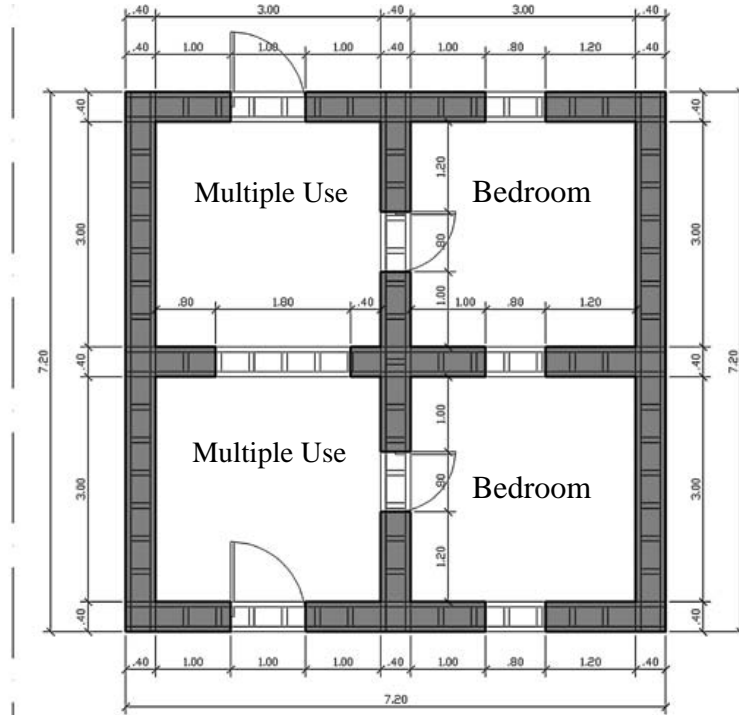

## Façade

This is the construction plan that will guide you through the steps you will need to follow for the outline and construction of your safer and hygienic home, reinforced with geogrid and with a dry ventilated latrine and a better family stove.

## Finished coastal-zone dwelling

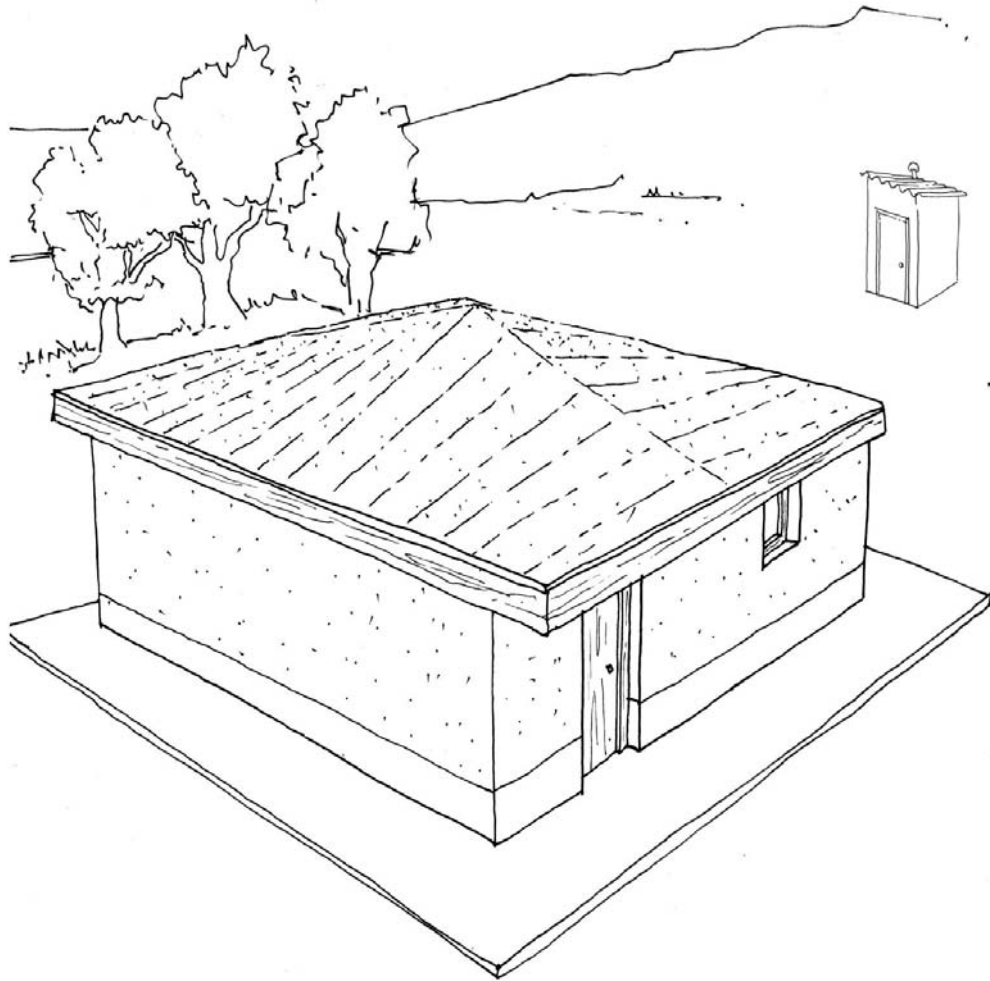

As shown in the illustration, your home and its roof will have 4 sides. This will create 4 independent environments inside the house that you can use in the way you find most convenient.

## 2) Necessary materials to make adobe bricks

### Adobe mold

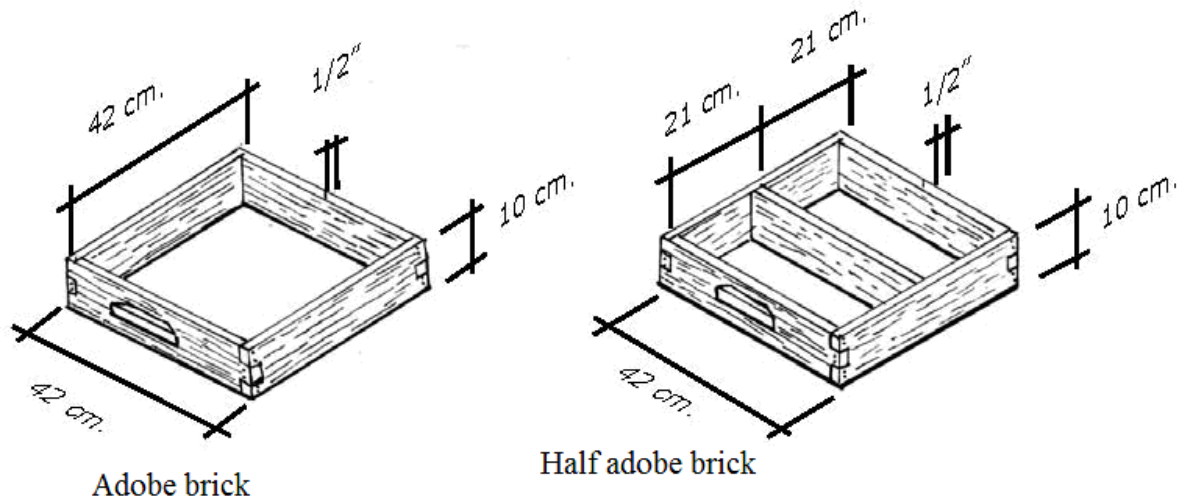

### Necessary tools to construct an adobe building

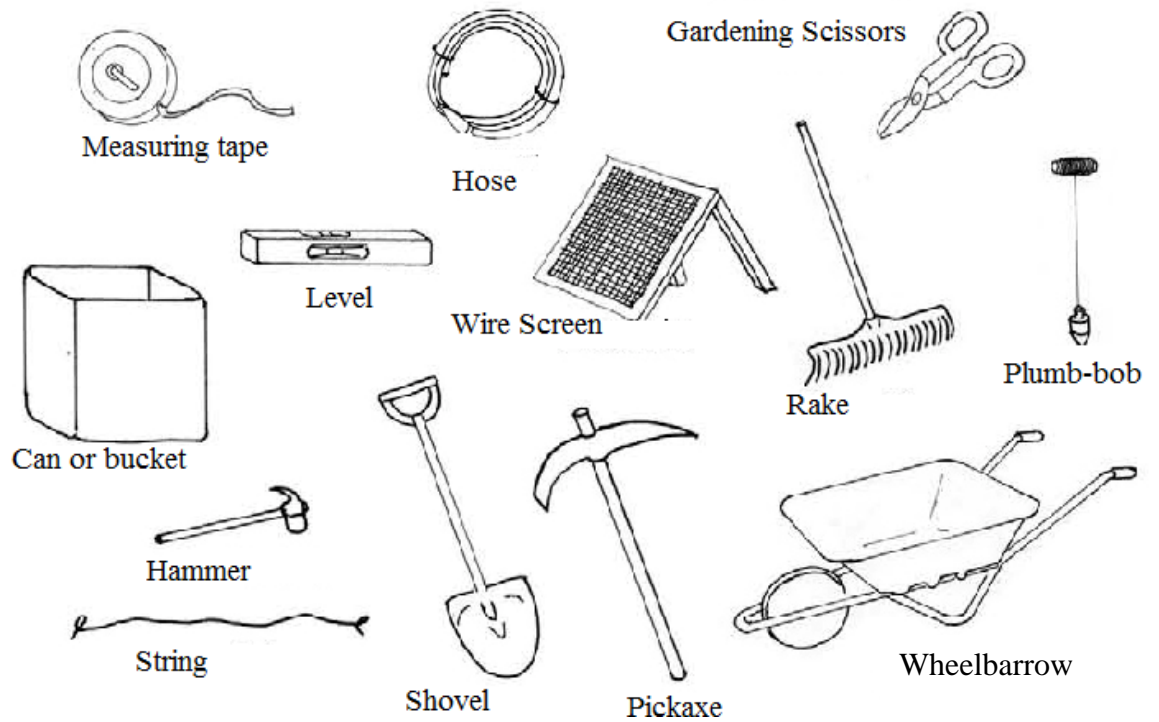

**Remember** that it's easier to make adobes using an adobe mold with no bottom lid. Use one if you can.

### 3. Finding the right soil

Finding the right soil is extremely important as you will use it to make the adobes, the mud for the joints between the adobes, and the plaster for the walls. You should be aware, however, that not all soils are equally adequate for these purposes. The right kind of soil is a mixture of fine gravel, sand and clay. When mixed with water, this kind of soil becomes easy to mold and shape.

#### How to test if the soil from a quarry has the right amount of clay:

To know whether the soil has the right amount of clay, carry out the following test:

**Step 1. Make six balls 1-cm wide using mud from the quarry.**

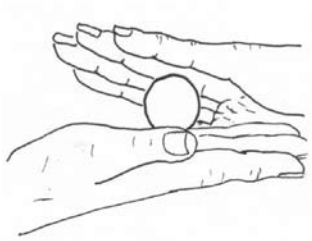

**Step 2. Let the six balls dry under cover for two days.**

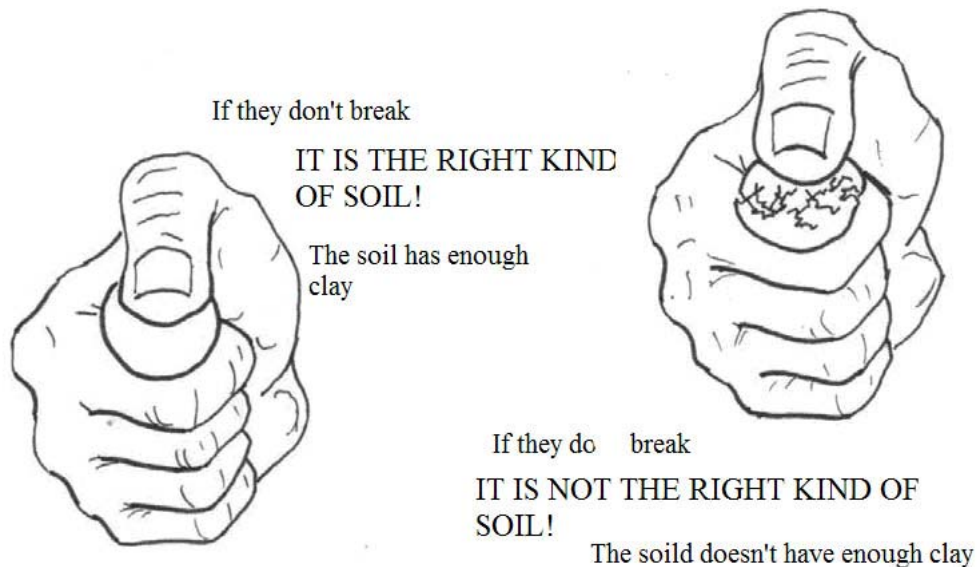

**Remember** that the mud and water mixture won't be strong enough when dry if there's not enough clay present in the soil. If, on the other hand, there's not enough fine gravel or sand in the soil, then the dry mud will shrink and crack.

## Preparing Adobe mud

**Step 1:** Shake the soil vigorously to get rid of all the rocks, then mix it with water to make mud. Let the mud rest for 2 days.



**Step 2:** Add the straw to the mud.

You should add 1 volume of straw to every 5 volumes of mud

**Step 3:** Mix the mud and the straw and knead the mixture well. You will use this mix to make the test adobes. You can use cane straw, wheat, grass or other fiber.



**Remember** that the straw you will add to the mud should be in 5-cm long strips. This will help to prevent the mixture from cracking.

### How to fill a mold without bottom lid:



**Step 1:** Place the mold in water before filling it with the mixture of mud and straw.



**Step 2:** Sprinkle the inside of the mold with fine sand so that the mixture of mud and straw won't stick to it.

**Step 3:** Place the mold under a drying yard and throw the balls of mud and straw into it. Using your hands, make the mixture even.

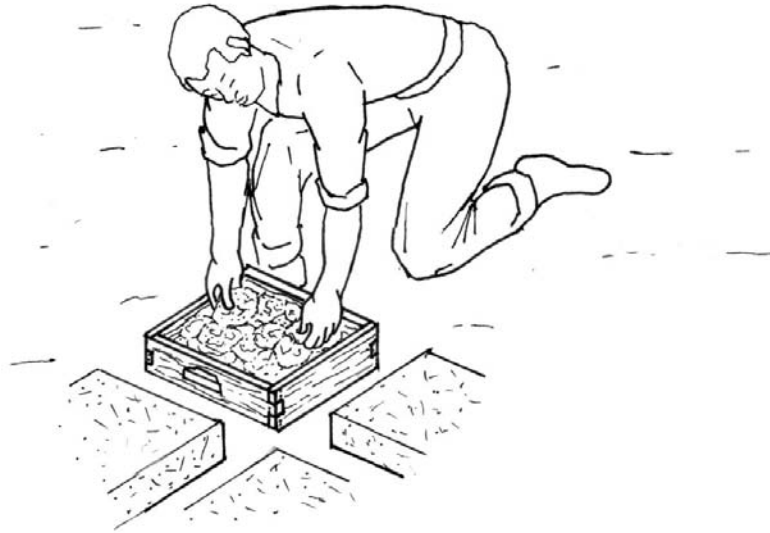

\* Check the next page for instructions on how to make the drying yard for the adobes.

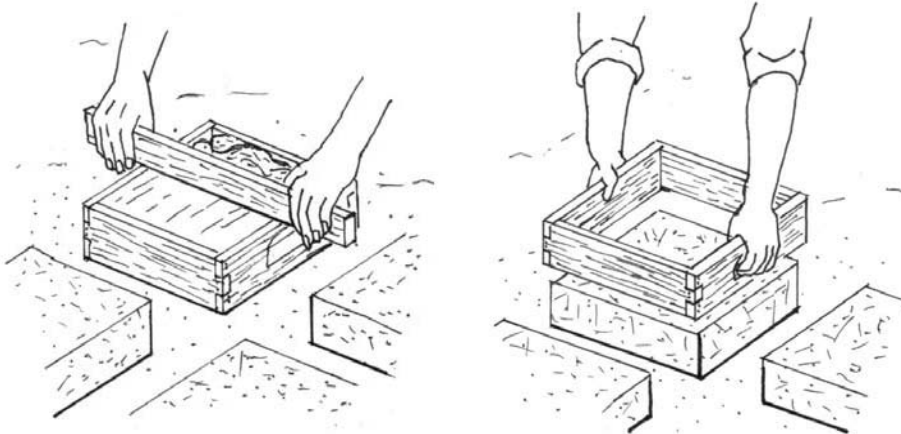

**Step 4:** Use a wet wooden ruler to even the surface of the mixture.

**Step 5:** Remove the mold. Be careful not to disturb the freshly made adobes.

## How and where to dry the adobes:

### Wind

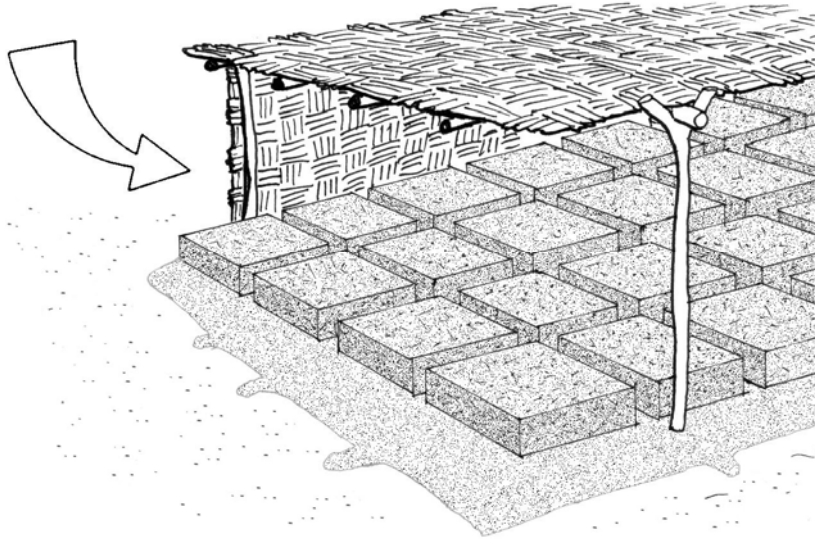

**Step 1:** Leave the adobes under cover to dry. You can protect them using cloths, mats or plastic.

**Remember** that the drying yard must be located in a flat area, free of rocks or grass, with a salt-free soil and should be under shade and protected from the wind. Remember to sprinkle its surface with fine sand.

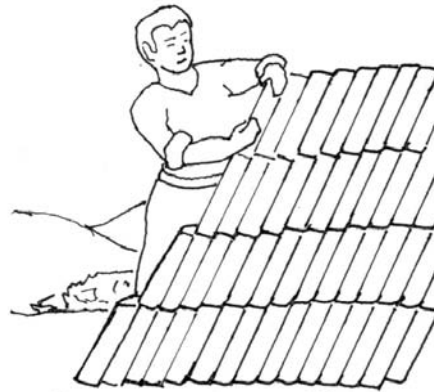
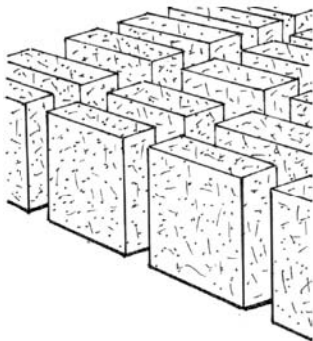

**Step 2:** After 4 days, stand the adobes on their side so that they dry evenly.

**Step 3:** After a week, pile up the adobes.

**Remember** that while it's best to dry the adobes under cover, you can also cover them with straw or fine sand to prevent them from cracking due to wind or sun exposure.



## How to make test adobes:

**Step 1:** Make several test adobes using the mud and straw mixture. Let them dry for a day.

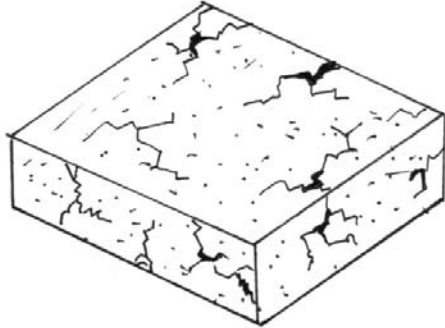

**Remember** to add coarse sand to the mixture if the adobes crack when dry.

**Step 2:** Add to the mud-straw mixture an amount of coarse sand equal to half the volume of the mud-straw mixture. Test the mixture again. If the adobes still crack, add the same proportion of sand again.

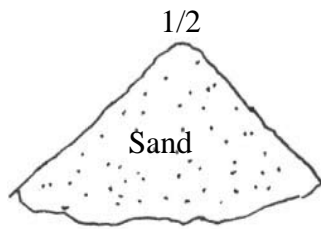

**Step 3:** Repeat Step 2 until the adobes stop cracking.

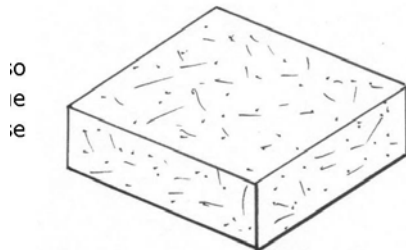
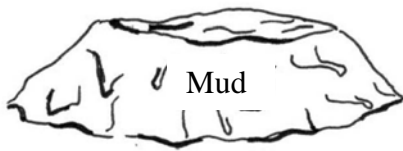

**Remember** that it is very important to test the adobes before you start with the construction. If the dry adobes crack, then that means there's too much clay in the soil. You should add more coarse sand to the mixture to prevent this from happening.

## 4. Building my home's foundations

### Outline and excavation:

**Step 1:** Clean and level the area where you will build your home. Following the draft, outline the future location of the house with chalk.

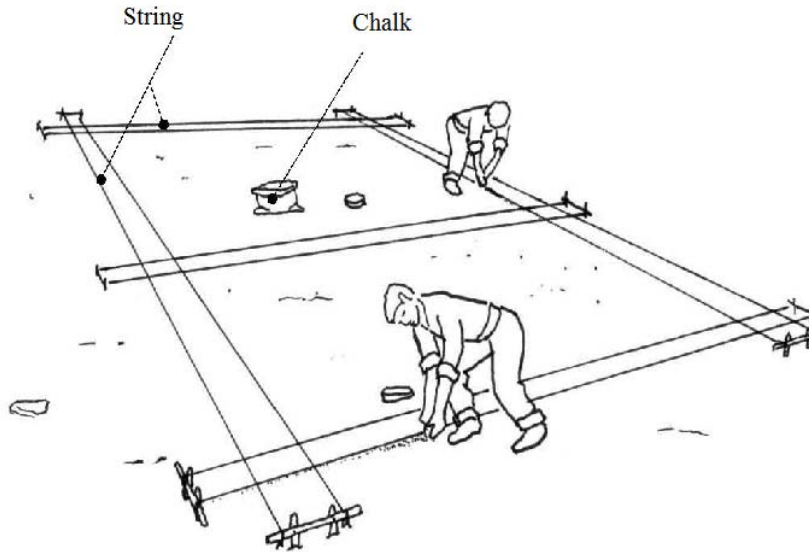

**Step 2:** Dig a ditch at least 60 cm deep.

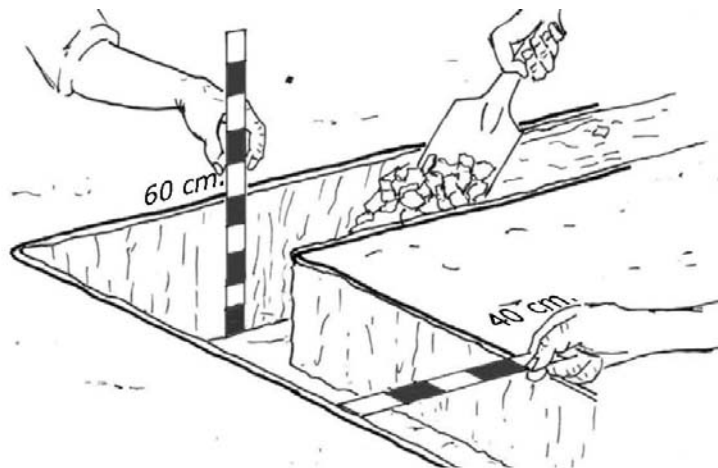

**Remember** that the groundwork of the foundation should never rest on loose soil or on one that's been filled, but on firm and stable soil.

### How to make the foundations:

**Step 1:** Fill half the ditch with the mixture and then put some large stones on top. Add some more mixture. This way, you will obtain a foundation that is mostly made out of stones (rather than more mixture).

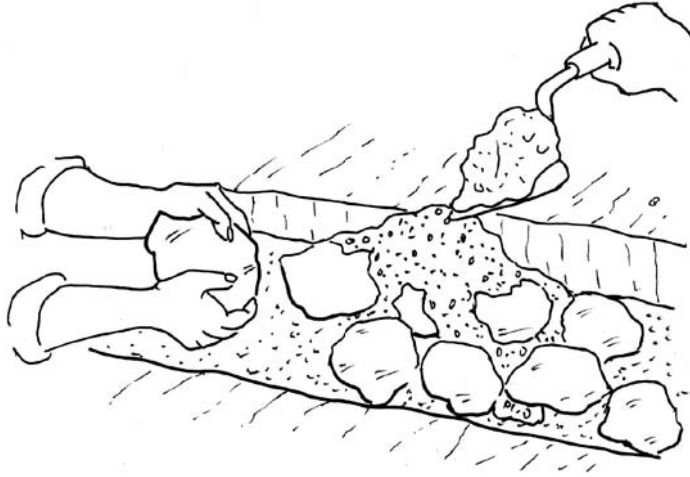

**How to prepare the mixture:** You should use the following proportion of each of these ingredients.

1 bag of cement



12 cans of concrete



Water (half the cement)

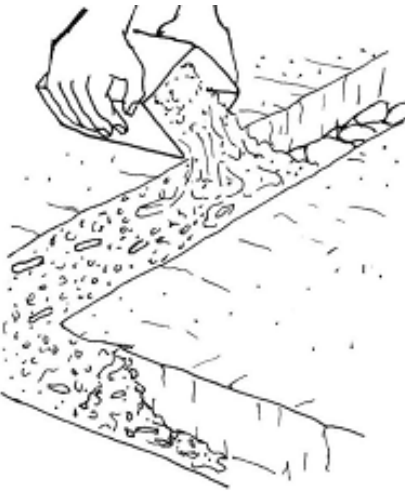

## How to build the plinth walls:

**Step 1:** Set the boards around the edges of the ditch as shown in the illustration. They should be 30 cm. high.

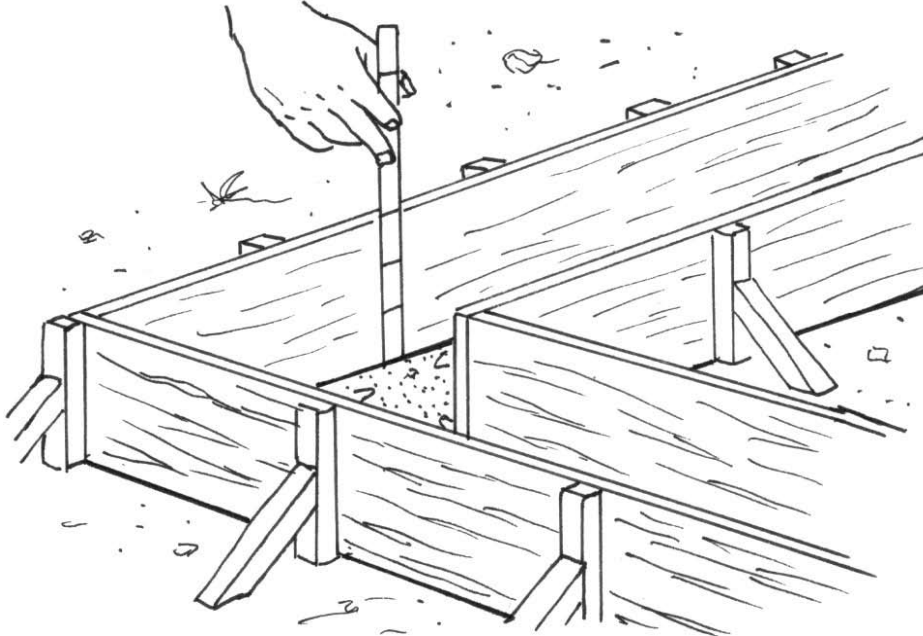

**Step 2:** Fill 20 cm. of the plinth wall with layers of the mixture and mid-sized stones.

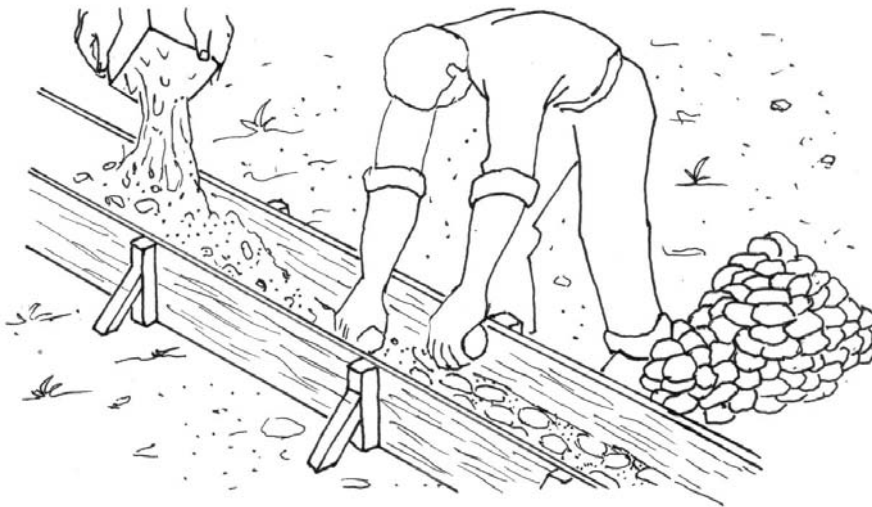

**Remember** that the stones should add up to be a quarter of the total volume of the plinth wall.

## How to place the wall reinforcement:

**Step 1:** You will use geomesh to reinforce both faces of the wall. The geomesh comes in 3-x 5-m. rolls, so you will need to cut it according to the height and length of your walls.

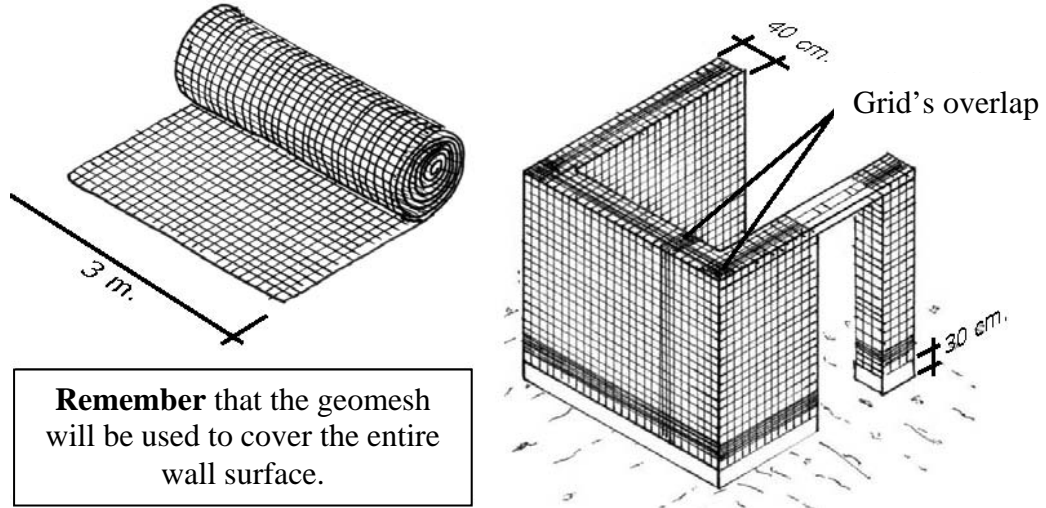

**Step 2:** Cut the geomesh following this illustration:

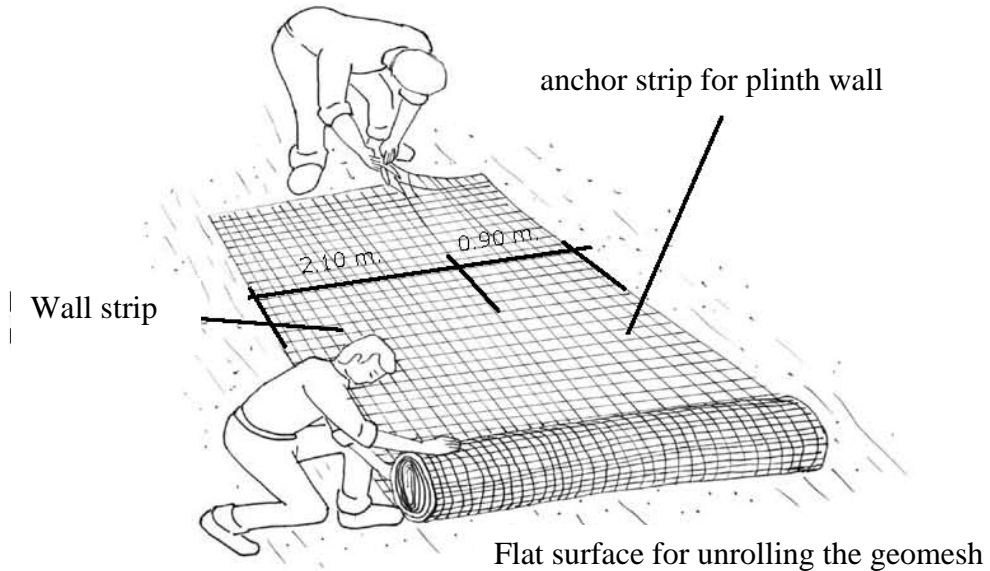

**Step 3:** To set the mesh on the plinth wall, use mid-sized rocks. This will prevent it from rising.

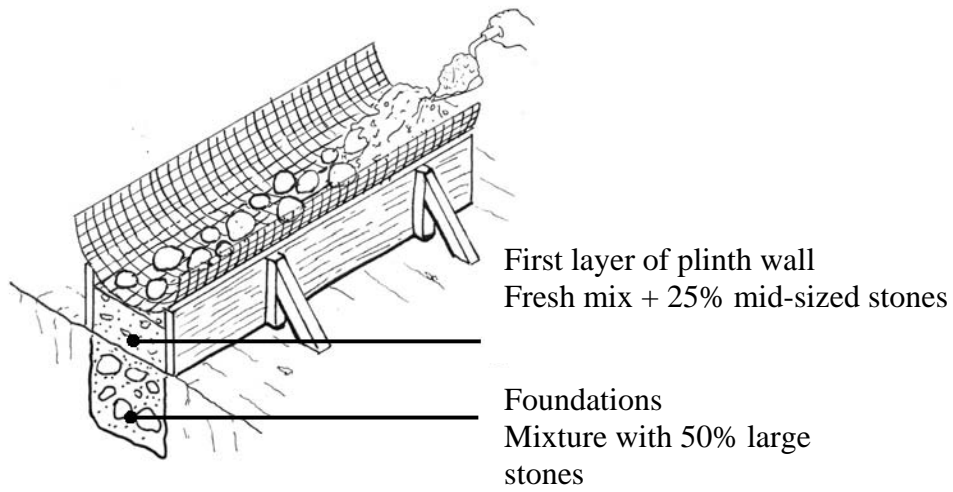

**Step 4:** Add a second coat of the mud-straw mixture to the plinth wall and apply a finishing coat.

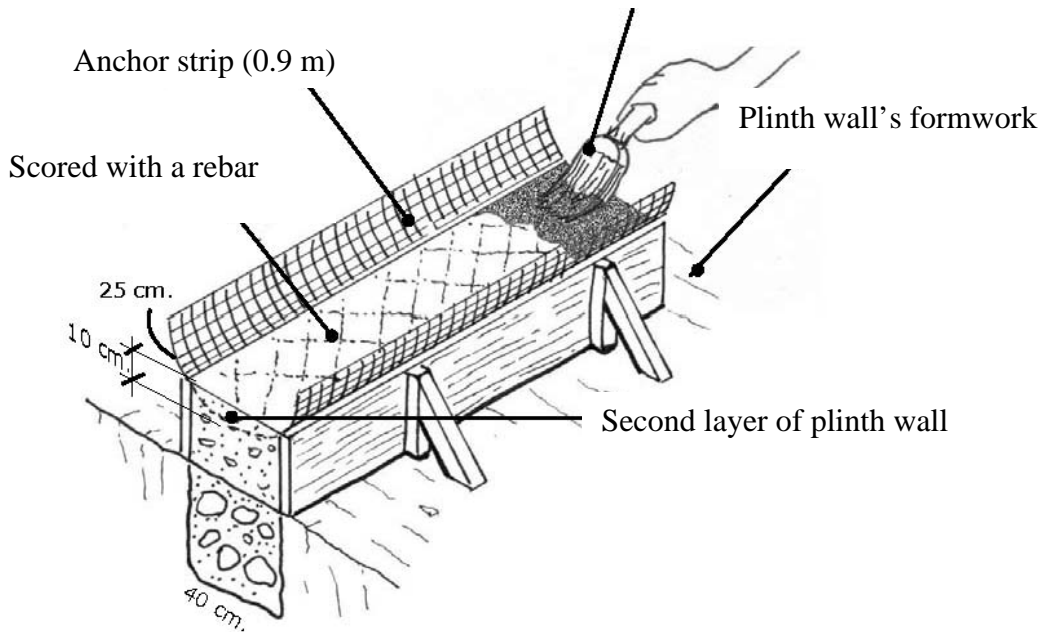

**Remember** to secure the anchor strip to the vertical grids on each face of the walls using plastic string to tie it in place.

## 5. Building my home's walls

Before you can start building your walls, you will need to prepare the mortar. This is a mixture that will help you bind the adobe bricks together. To prepare the mortar you'll need to let the mud rest for two days before mixing it with the straw, which should be cut to be 5 cm long.

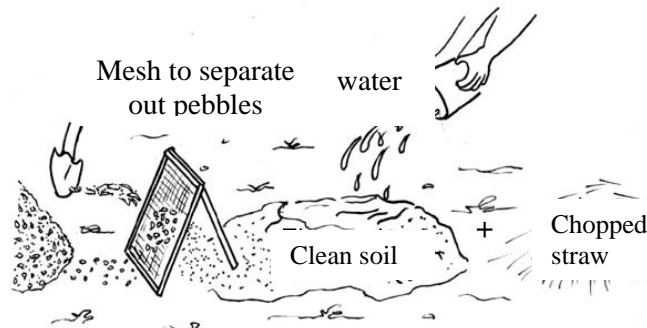

### How much straw and mud should I use to prepare the mortar?

To know how much straw and mud you should use, carry out the following test:

Make 5 adobe sandwiches using the mortar as the filling. The mortar in each sandwich should have different proportions of mud and straw.

Open the sandwiches after letting them rest for a day. Place them so that they are standing on one side.

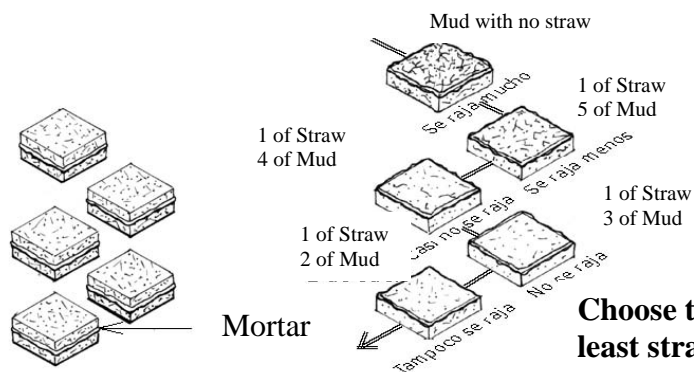

**Remember** that the strength and resistance of the walls will depend on the quality of the mortar you use, rather than on the quality of the adobes. The mortar shouldn't crack, that's why it needs to have straw. It shouldn't be more than 1-cm thick.

**Step 1:** Once you have chosen the right mortar, soak the adobes thoroughly before using them for construction.



**Step 2:** Before placing the first course (row) of adobes, soak them so that the mortar takes longer to dry and doesn't crack.

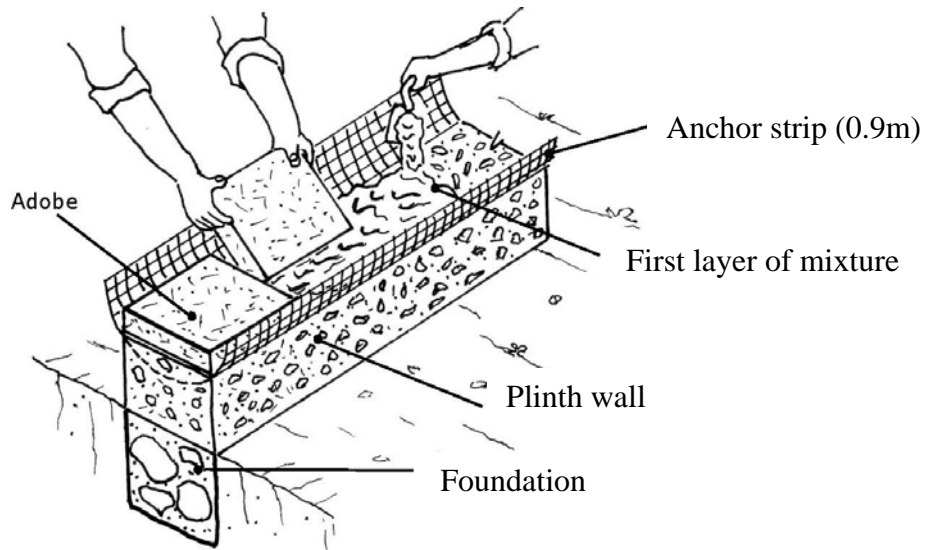



## How to build a narrow lean concrete base:

Follow the indications shown in these illustrations:

### In a corner

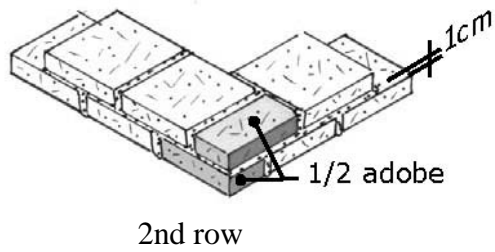
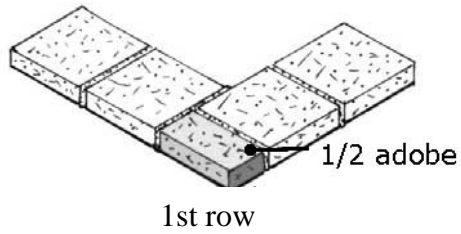

### (t) joint

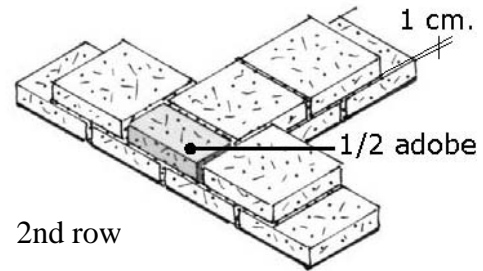
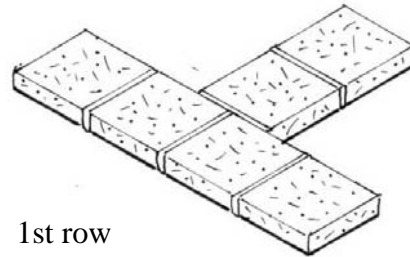

### Cross joint

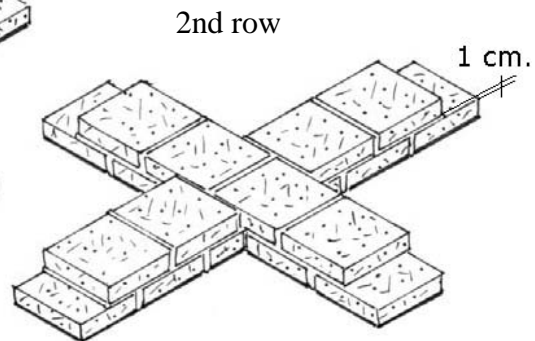
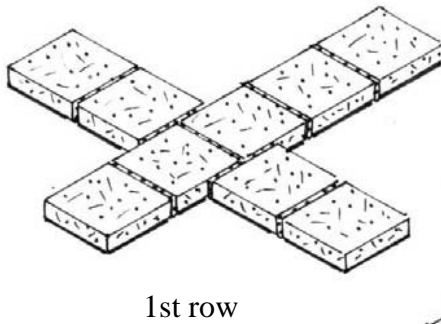

**Remember** to use the adobes and the half adobes to make plinth for the first and second row of the walls. The mortar should be 1-cm. thick.

**Step 3:** To join the grids you should use plastic string as shown in this illustration:

4 strips should be placed horizontally every 30 cm.

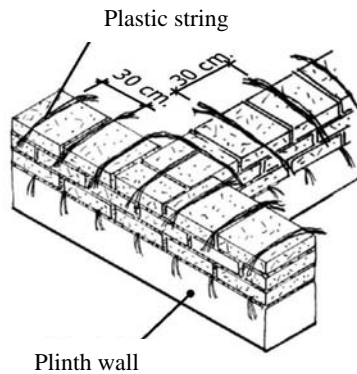

The maximum vertical space between the plastic strips should be of every 3 rows.

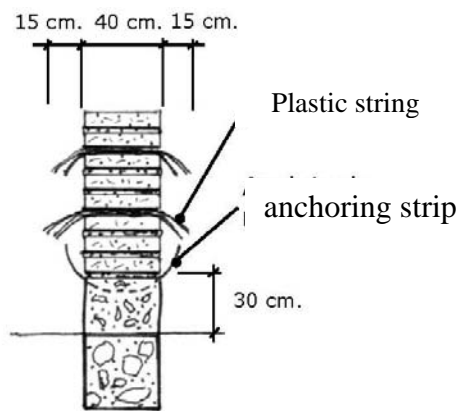

The plastic strings should be cut in 70-cm. long strips, and should be placed leaving a 15-cm extra length on each side of the wall. These will be used to tie the grid.

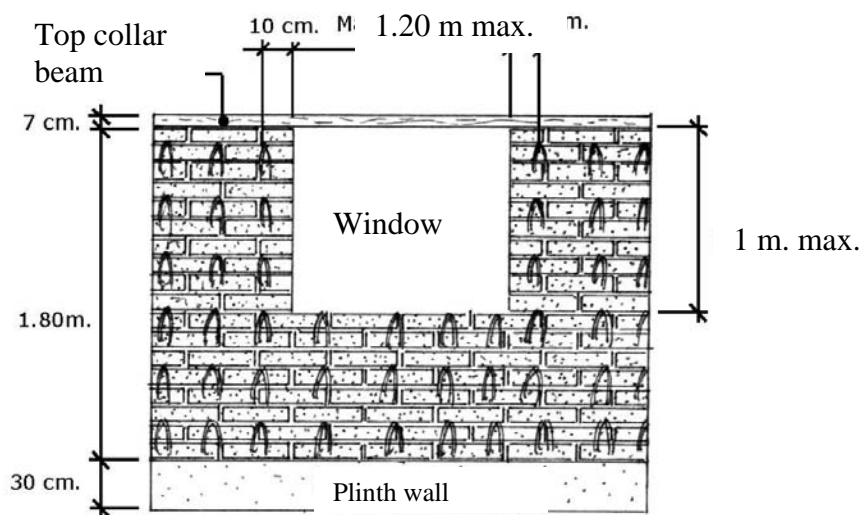

**Remember** that the plastic string should be put in the row of adobes that is just below the window. You should leave a 10-cm gap between the edges of the doors and windows and the plastic strips.

## How to make the top collar beam:

You should make the collar beam by separate segments on the ground and assemble it over the walls.

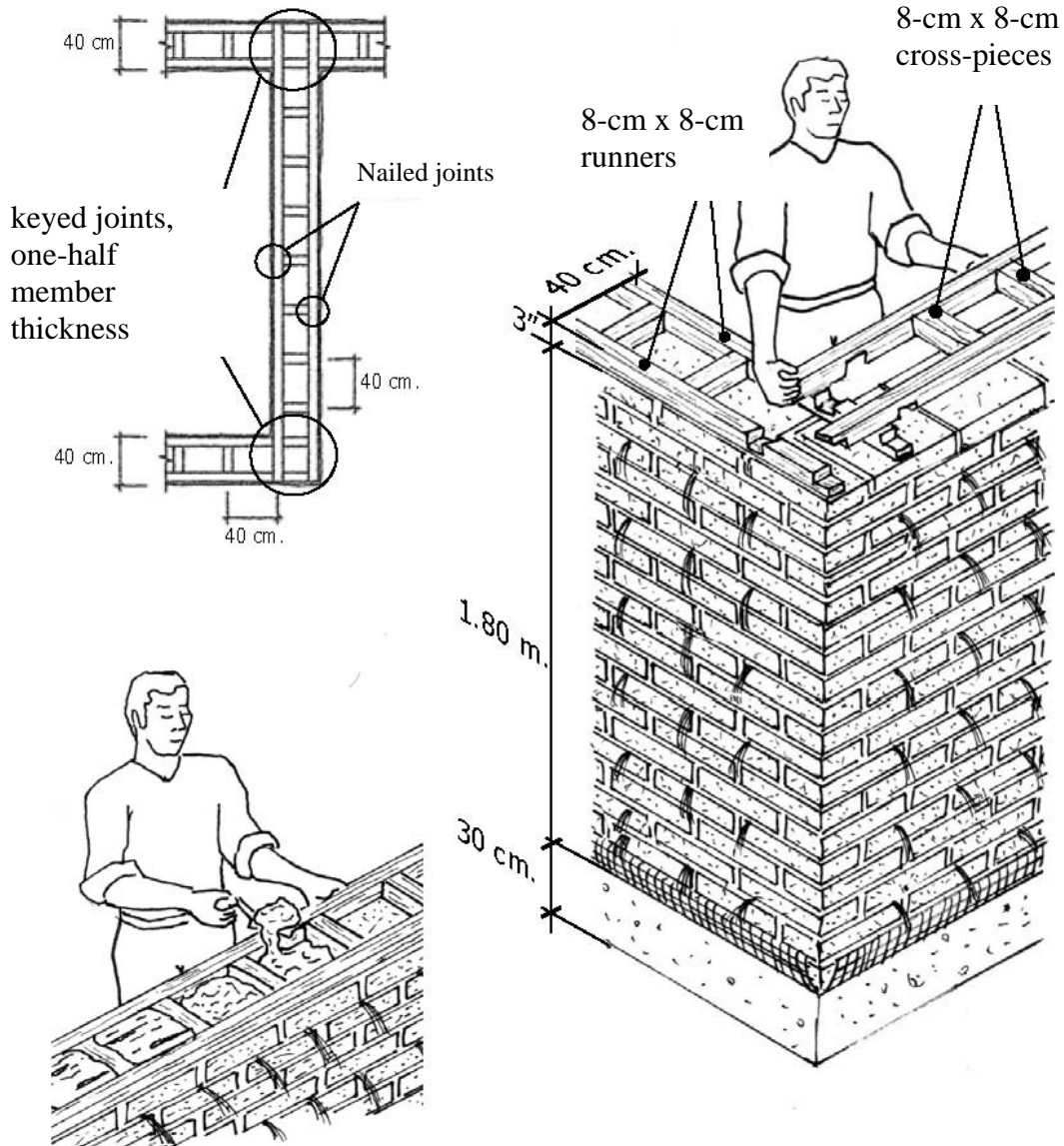

**Remember** to put mud between the cross-pieces and the runners.

## How to set and fix the geomesh in place:

**Step 1:** One person should use rope to pull the geogrid in one direction, while a second one nails it in place and ties it using plastic string.

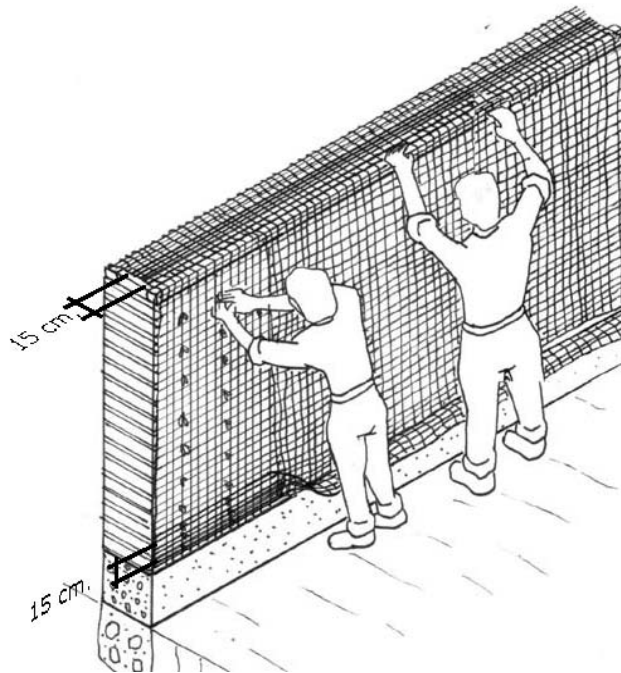
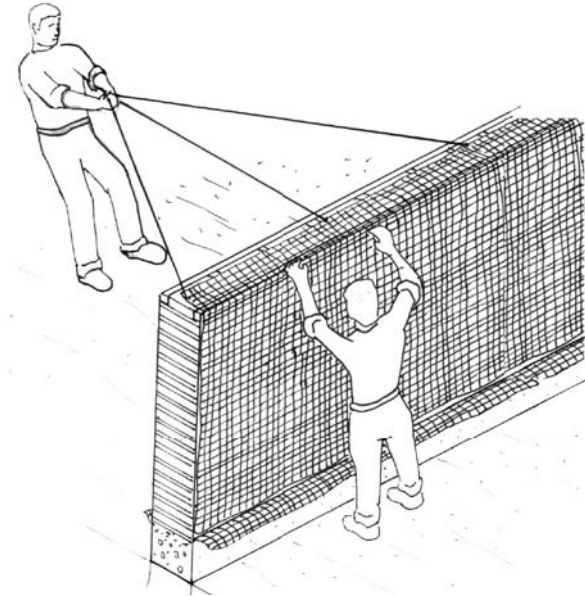

**Step 2:** To fix the geomesh in place, two men are needed: while one stretches it, the other one should use plastic strips to tie it from the top down and then join it with the anchoring strip. Overlap the grids over the collar beam, tie them with plastic string and then nail them to the beam.

## How to cut the grid around the doors and windows:

On doors: cut and fold the mesh on each side of the opening.

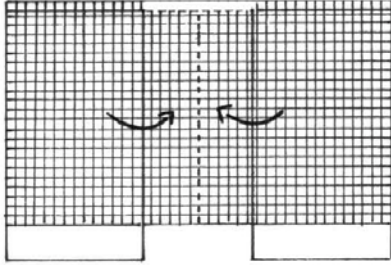

Front face and opposite face  
(2 cuts)

On windows: Following the illustration, cut and fold the grid on each side of the opening.

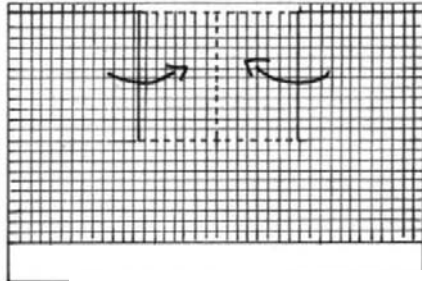

Front face (3 cuts)

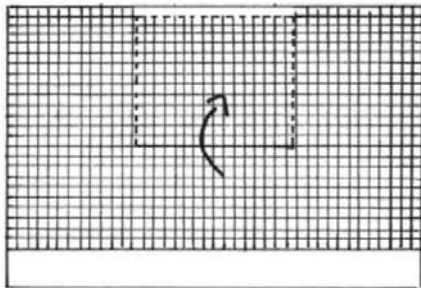

Opposite face (3 cuts)

The grids should overlap at least 15 cm. The overlaps of the mesh should be tied and secured with plastic string.

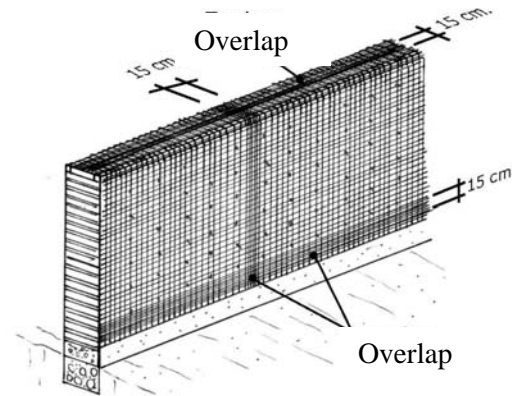

## 6. Roof construction

After fixing the collar beam in place using the geomesh, nail 5-cm x 15-cm straps of geomesh to the collar beam and the truss every 60 cm.

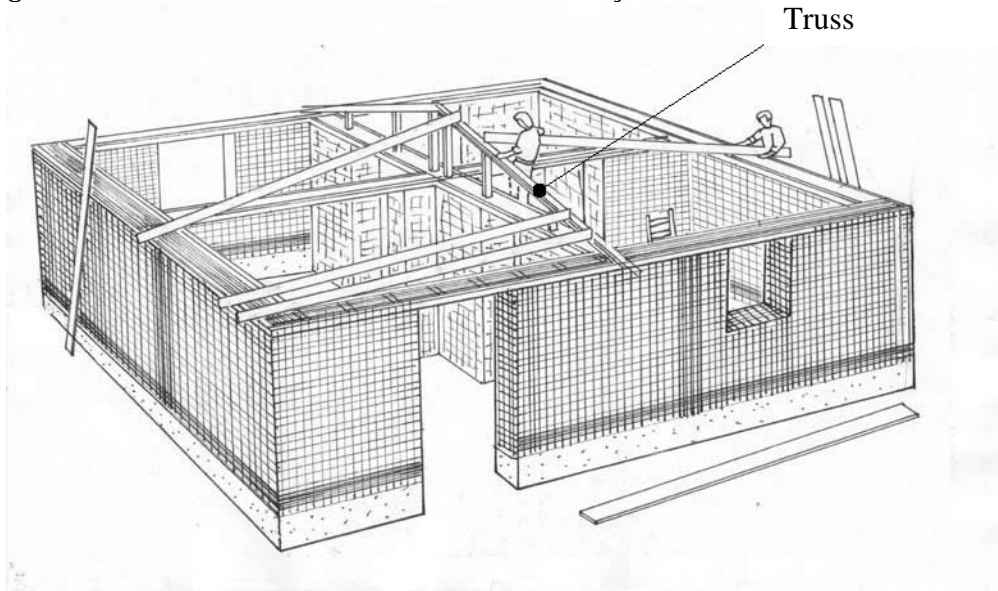

### How to make the roof truss:

Take the following illustration into account:

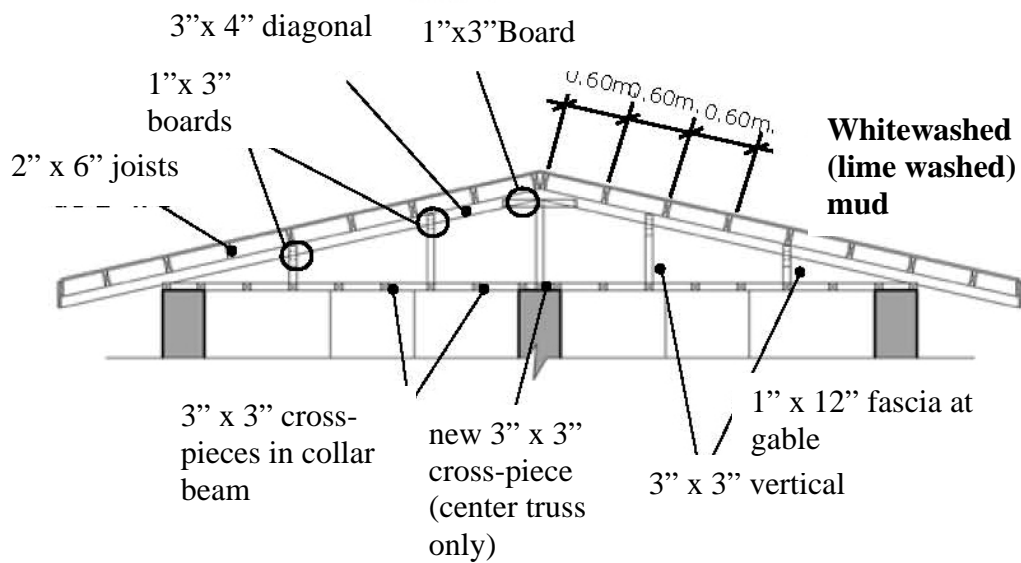

## Roof truss details (1)

Joint between vertical and diagonal elements:

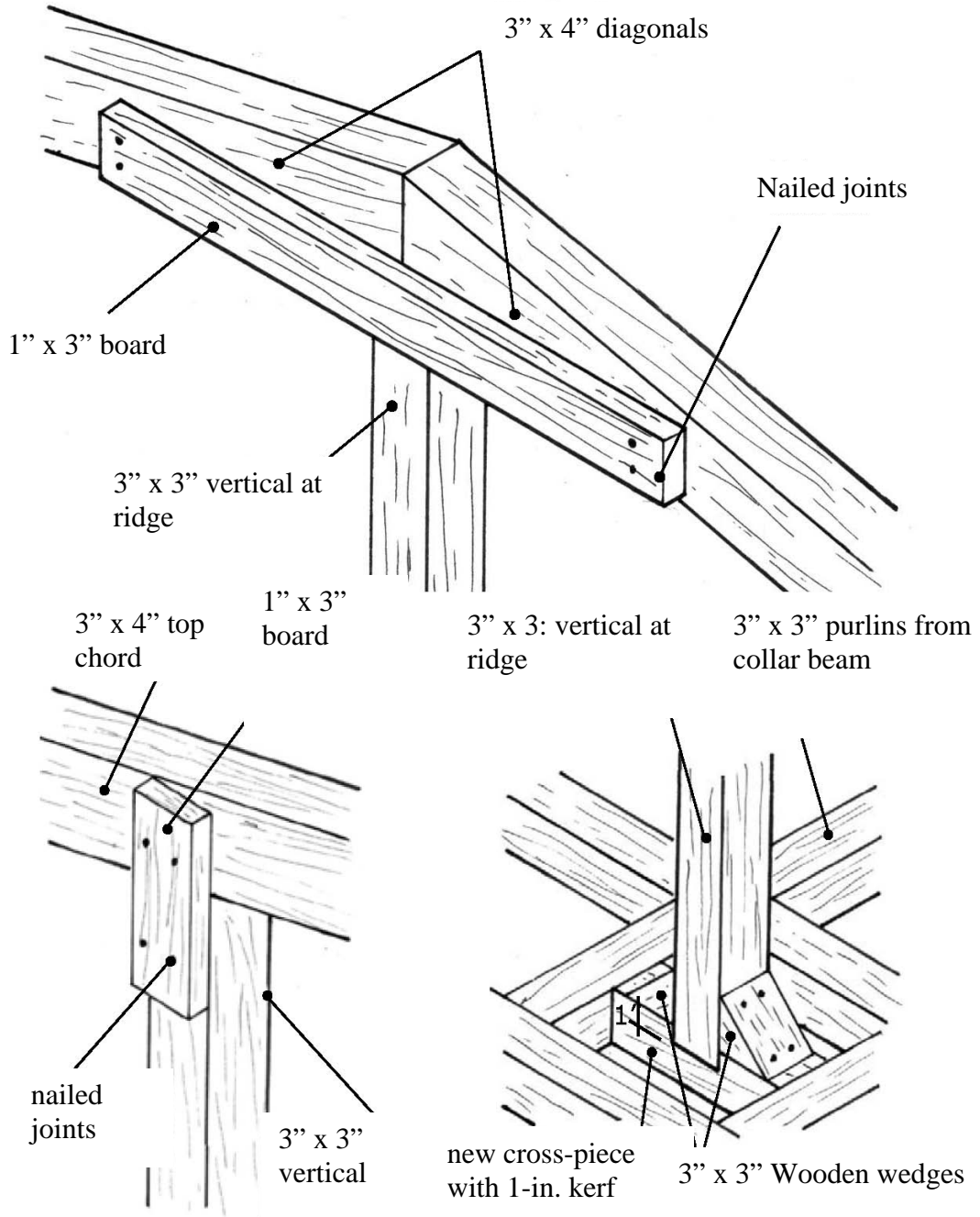

## Roof truss details (2)

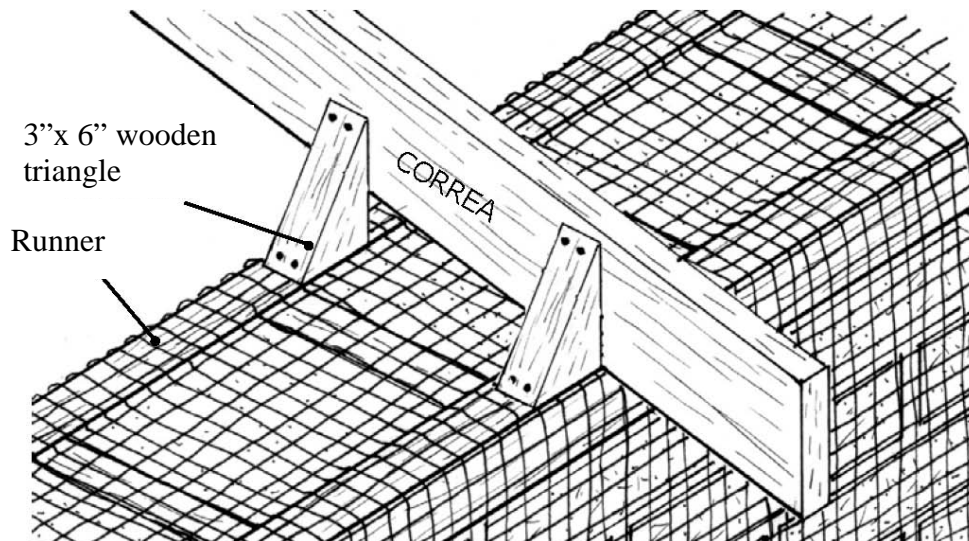
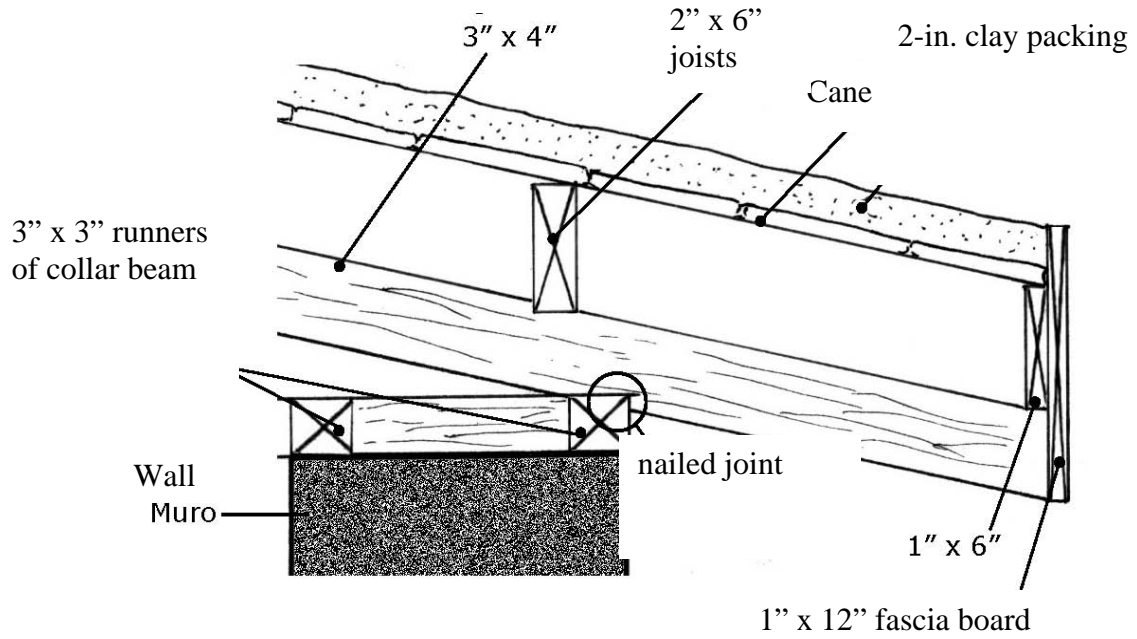



## How to set the beams, cane, mats and mud in place:

**Step 1:** Place the cane for the roof cane over the 2" x 6" joists, forming a curved surface.

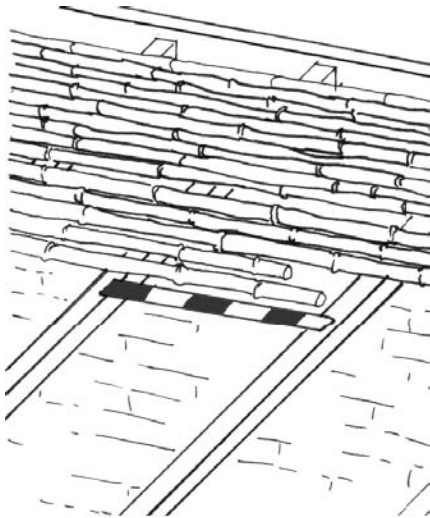

**Step 2:** Nail 2 mm. plywood strips or crushed cane to the cane every 20 cm to fix it in place. Make sure that it coincides with the beams.

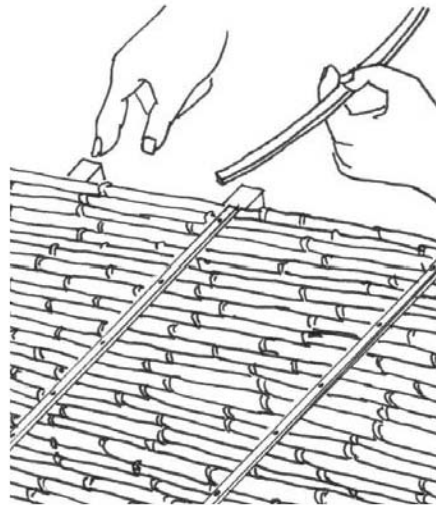

**Step 3:** Place a reed mat over the cane.

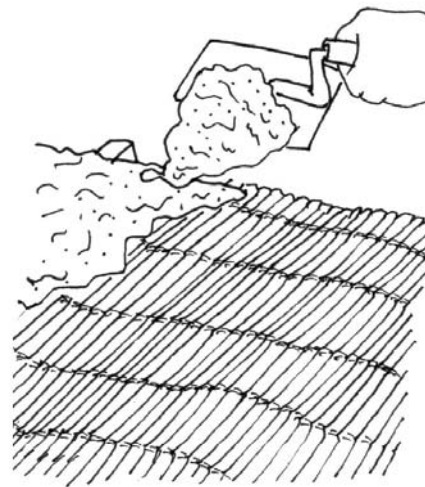
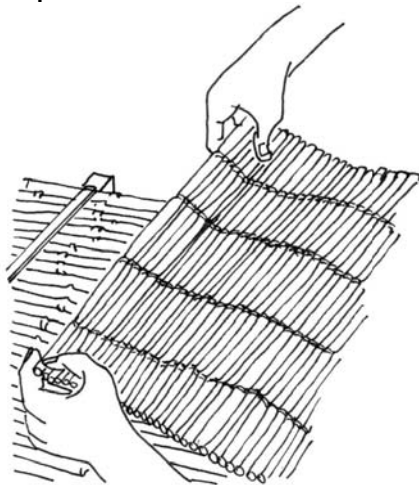

**Step 4:** Apply two 2.5-cm. thick mud layers mixed with a lot of straw. Apply one layer each day.

## 7. Finishing the walls:

### How to plaster the walls:

It's advisable to apply the plaster to the walls in two layers: the first one should be approximately 2.5-cm. thick and the second one should only be 0.5-cm thick. The second layer will cover any cracks that may form in the first layer.

Use the mortar mixture for both the thick and the thin layer. Use 1.5 cm. straw only in the second layer.

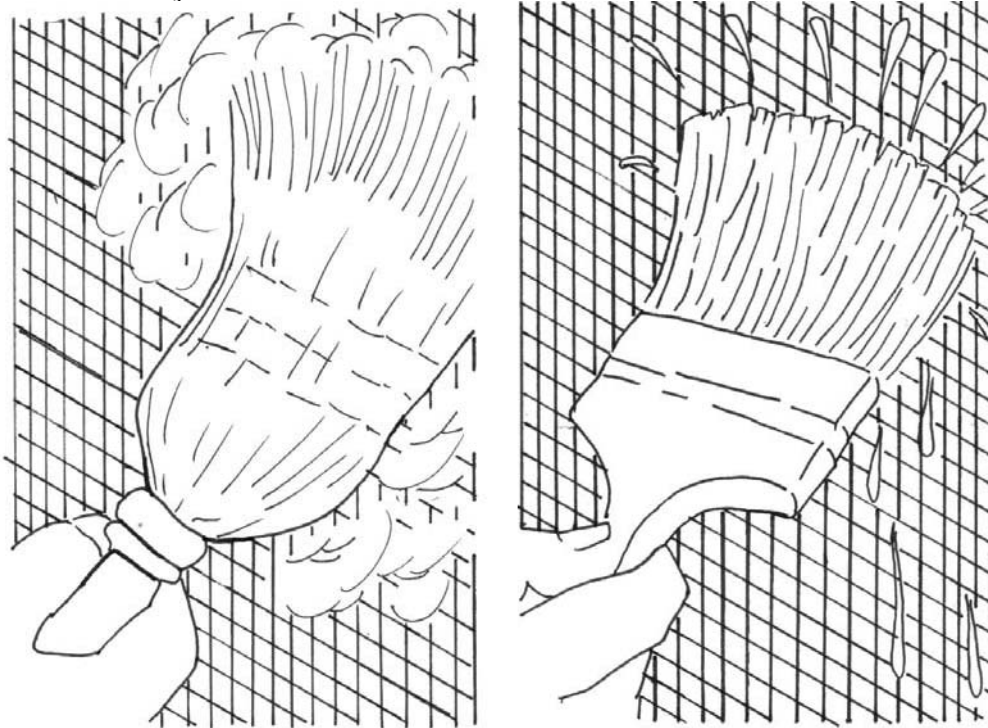

**Remember** that if the plaster cracks, its will be less resistant to rain. You can fix this by adding more straw to the mud. Remember to dust the wall and to wash its surface before plastering it.

## How to apply the mud coating on the mesh:

**Step 1:** Place the mud balls on the wall and press them down with your hands.

**Step 2:** Smooth the surface and let it dry.

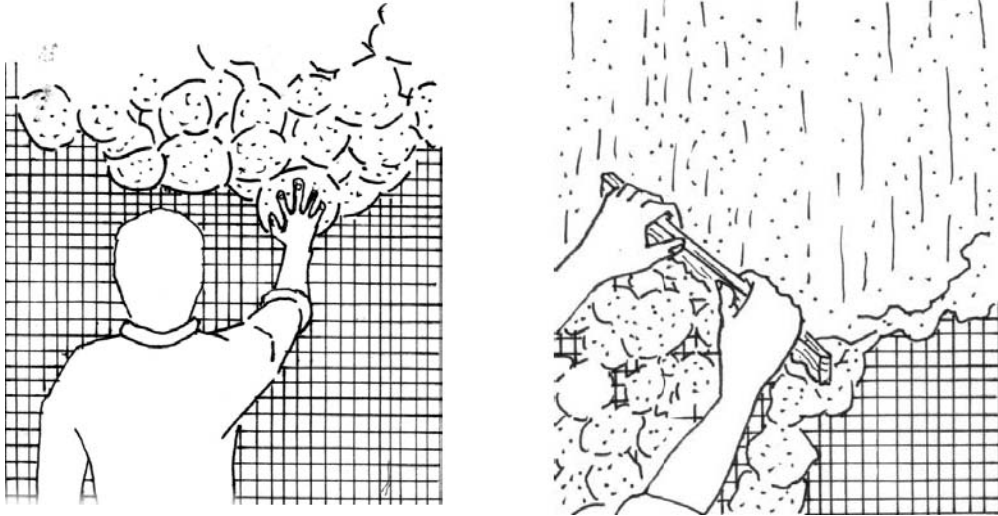

**Step 3:** Wet its surface again and then use a trowel to apply a thin second layer of mud. Let it dry.

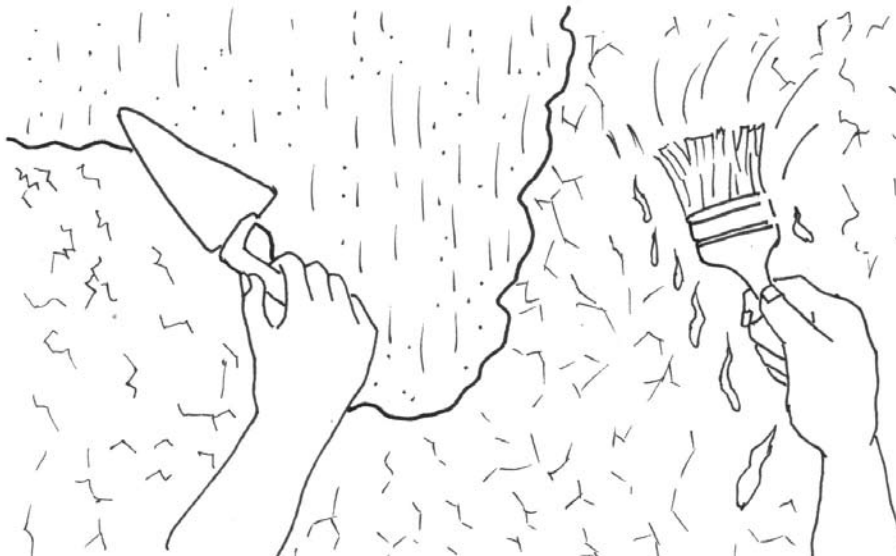

**Remember** that for the wall to have a better finish, the second layer should completely cover the cracks of the first layer.

### How to polish the wall:

You can get an even and shiny finish by rubbing the surface of the wall first with a smooth stone, and then with a smoother one.

**Step 1:** Rub the surface with a circular motion using a smooth stone.



**Step 2:** Using an even smoother stone, continue to rub the surface.



**Remember** that the stone polishing helps increase the strength of the plaster.

## 8. Making a better stove



It is very easy to build a better family stove using inexpensive materials that you can easily find in your community. This kind of stove has several advantages over the traditional firewood one:

- It helps to prevent lung diseases and respiratory infections that can be caused by the smoke of firewood kitchens.
- It will help save wood, as it conserves enough heat to cook with less fuel.
- It enables families to prepare food more hygienically.
- It uses only local materials.
- Families can easily make them themselves.

### What do we need to make a better family stove?

- A 1 m. x 80 cm. area
- 23 40 cm. x 20 cm. x 10 cm. adobe bricks
- 4 cans of clay and 2 cans of sand
- three 30 cm. flat irons or 7 reinforcing bars (you can use rails, bars, tiles, bent cans, etc.)
- 3 handfuls of guinea pig hair
- 3 handfuls of chopped straw
- Horse or donkey manure
- Cactus juice
- Water
- 2 cans or empty oil containers to cover the stove's chimney and base

## How to make a better family stove:

**Step 1:** Using the adobes, build a platform on top of which you'll build another platform to be used for the stove's burners.

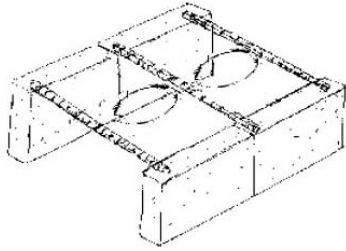

**Step 2:** Place 3 or more flat metal bars or reinforcing rods on top of the 4 bricks. These will hold the saucepans.

**Step 3:** Apply a mud, cactus juice and straw coating to the second platform. You will hold the platform in place using a can as shown in the illustration.

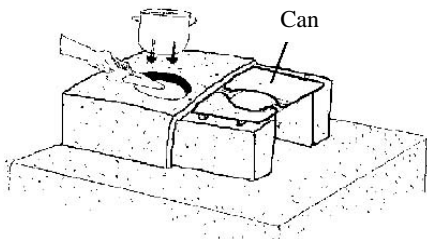

**Step 4:** To shape the stove's burners, place the saucepans on the platform and apply pressure while rotating them until they fit.

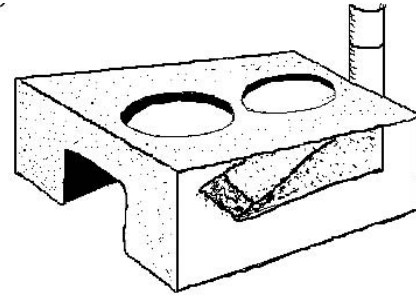
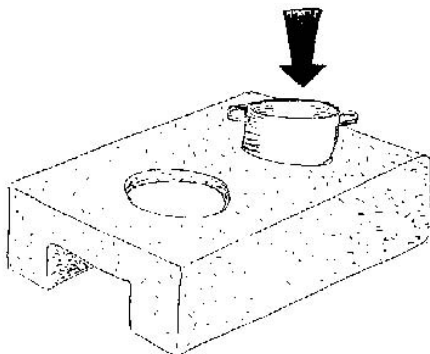

**Step 5:** Using the same mixture, build a clay ridge in the middle of the floor of the second burner. This will make the fire reach the second saucepan and will also regulate the exit of the smoke through the chimney. Make the chimney out of tin oil cans.

**Step 6:** To make the chimney, dig a tile-wide hole through the wall.

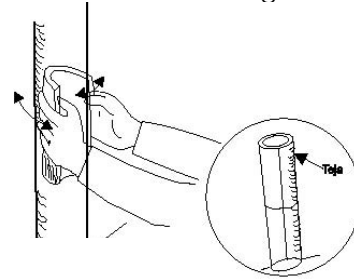

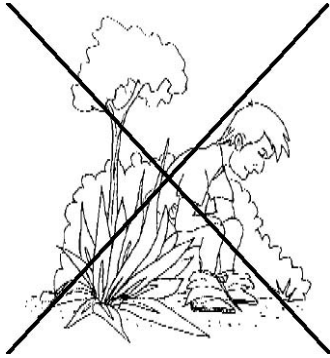

## 9. Dry ventilated latrine:

This is an appropriate and hygienic system where human waste is deposited. This helps prevent environmental damage and to preserve the community's health.

### How to make the latrine:

**Step 1:** Locate the latrine on firm ground that is not prone to flooding. The minimum horizontal distance between the latrine and a source of water shall be 20 meters.

**Step 2:** Dig a 0.8 m x 0.8 m hole. It should be 1.80 m deep.

**Step 3:** Construct a tiling of stone or adobe to keep water from entering.

**Step 4:** Use wood beams or tree-trunks to internally reinforce the loose soils. The walls can be made using reinforced adobe, wood or fibrocement sheets over a wood structure. For the roof you can use whitewashed (lime-washed) mud, fiber-cement sheets or tiles.

**Step 5:** Make a ventilation window on the top part of the booth and cover it using a mosquito net.

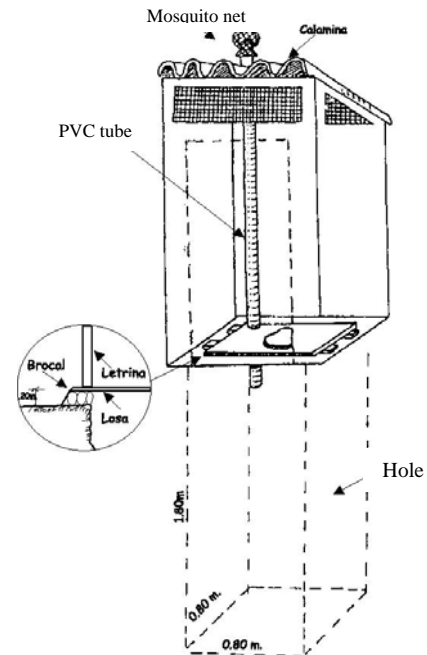
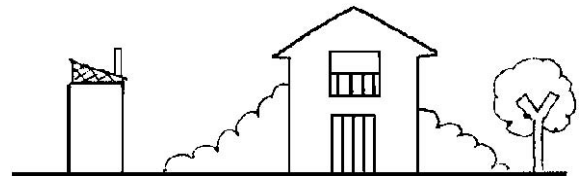

## Latrine use and maintenance:

Remember to:

Always keep the floor, the toilet or squat toilet clean. Make sure to clean them every day.

Never throw or drop in the latrine:

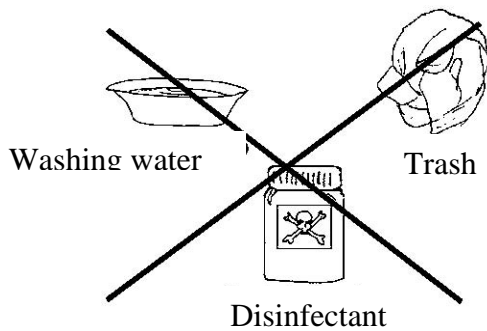

Always keep the booth's walls and surroundings clean.  
To avoid insects, keep the latrine's bowl or hole always covered.  
Never house hens or any domestic animals in the booth.  
Never use it to store garbage.

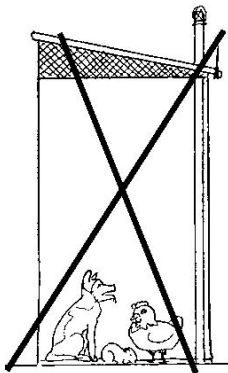
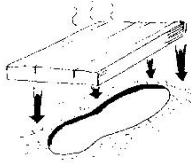

to avoid bad smells, toss in 2 shovelfuls of cow, donkey or horse manure every 2 weeks.

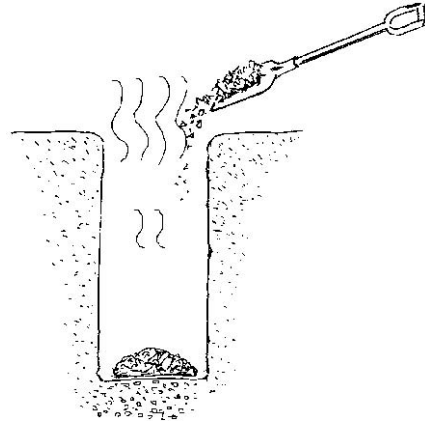

When half a meter is left for the latrine to fill, throw quicklime first and then mud in it. Close it up and make another one.

Always wash your hands with soap and water after using the latrine.

If you don't have a drain, make sure there's always a sink with water close to the latrine. Make sure that everyone in your family uses it.





In Peru, a country with permanent earthquake hazards and a variety of geographic landscapes, getting to know and value the different construction materials present in our surroundings becomes a necessary task. This booklet shows the steps that should be followed to design and build adobe dwellings. Addressed to construction managers, masons and the general public, it is intended as a helpful tool for anyone intending to use adobe as a solid and long-lasting building material for strong and secure dwellings. This manual was initially conceived as a way to help our fellow citizens affected by the earthquake that occurred in August 15, 2007. We hope that it will contribute to the re-establishment of adobe as an effective and durable construction material.