

# GYPSUM PROCESSING AND USE



Gypsum is a particularly useful processed material. Its main application is as a building material, mostly produced as so-called plaster of Paris for plastering walls and making decorative features in buildings. However gypsum also has a diversity of other uses including making writing chalk, soil conditioning for agriculture, making moulds for pottery, as an additive in the manufacture of Ordinary Portland Cement (OPC), in surgical splints, in increasing the hardness of water, as an additive in certain foods such as tofu and in some types of medicines and pharmaceuticals. Its construction uses can also include external applications, such as in making walling blocks, where the climate is generally dry and not prone to the dampness that damages common types of gypsum.

Gypsum can be processed relatively simply with basic equipment and techniques as well as on a large and industrialized scale as is done in some countries such as the United Kingdom. It is made from deposits of gypsum rock or sand. Raw gypsum is heated to drive off a portion of the chemically combined water. The resulting gypsum plaster, when re-combined with water, sets like cement, only much faster.

The main advantage of gypsum plaster over some other binders is that temperatures of only 120 to 160 °C are required during production, so high-temperature kilns are not needed.

## Raw Material

Gypsum rock (calcium sulphate dihydrate –  $\text{CaSO}_4 \cdot 2\text{H}_2\text{O}$ ) was formed in geological time through the evaporation of seawater. It is often laid down in beds, ranging in thickness from a few centimetres to several tens of metres.

Because gypsum rock is slightly soluble in water it is not usually found above ground in wet or damp areas, but may be found underground, where it is not affected by the water table. In dry regions it may also be found on the surface, sometimes in the form of gypsum sand.

The presence of gypsum on or just below the surface of the ground is often indicated by changes in vegetation; some plants thrive on gypsum-rich (alkaline) soil whereas others are not at all tolerant of those conditions.

Gypsum rock is usually white or colourless, although it may sometimes have grey, yellow, pink, or brown hues. Gypsum is much softer than minerals of similar colour, such as calcite or quartz, and is the only one that can be scratched with a fingernail. If a piece of gypsum rock is held over a flame it will turn cloudy and opaque and give off water.

Some gypsum sand deposits contain only about 60 per cent gypsum, and these are not very suitable for producing a plaster; those containing more than 80 per cent would be most suitable.

Hinged corner

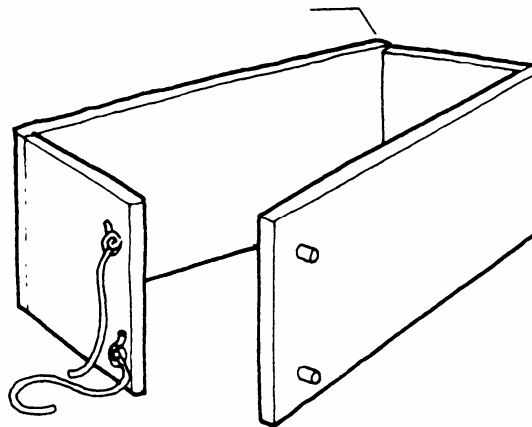

Figure 1: Mould for making gypsum plaster wall blocks

Gypsum is also produced as a by-product of the phosphate fertilizer industry, but in some cases this is slightly radioactive and little use is made of it at present, except as an additive in the manufacture of Portland cement. More recently by-product gypsum is also available from flue gas desulphurisation; a process for cleaning up emissions from chimneys to reduce the quantity of sulphurous gases flowing into the atmosphere.

### Dehydration: Rock into plaster

Gypsum rock is converted into gypsum plaster by driving off some of the chemically combined water. Heating gypsum at 120 °C for one hour results in a hemi-hydrate ( $\text{CaSO}_4 \cdot 1/2\text{H}_2\text{O}$ ) – with three quarters of the water removed. Gypsum hemi-hydrate is also known as Plaster of Paris. Prolonged heating over several hours results in the formation of anhydrite with practically none of the chemically combined water left. Anhydrite sets more slowly and is a slightly stronger plaster than hemi-hydrate, but with the drawback of added production cost. In practice, a simple production system would most likely give a mixture of the hemi-hydrate and anhydrite phases. Much of the commercial plaster produced industrially today is Plaster of Paris. Gypsum plaster sets by chemically combining with water to form solid calcium sulphate dihydrate.

A special type of plaster, called alpha hemi-hydrate, can be produced by reacting the raw material under high pressure steam in strictly controlled conditions. This plaster sets harder and is used in dental work and as a modelling plaster, but is impossible to produce without expensive production equipment.

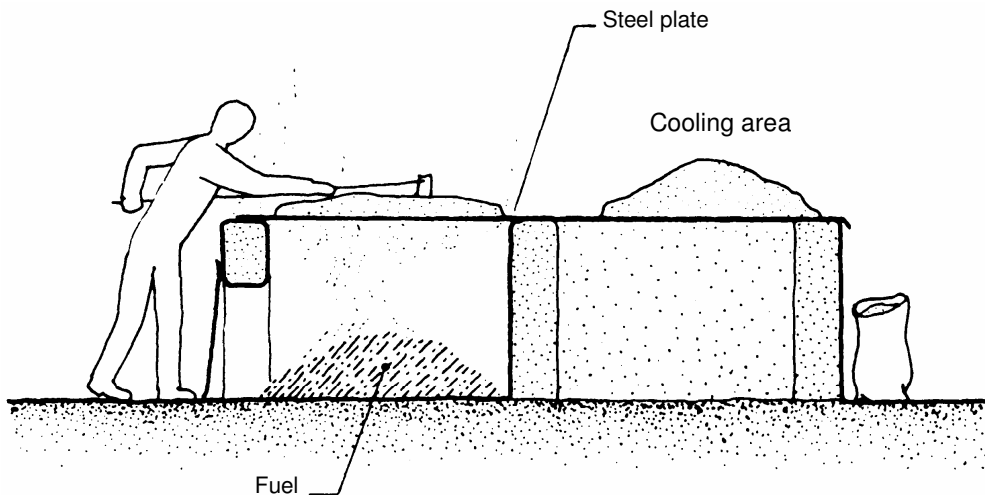

Figure 2: One simple production method is to heat the gypsum on a flat metal plate above a kiln

### Properties of gypsum plaster

The properties of gypsum plaster will vary depending on the method of production. With relatively simple burning and processing techniques the plaster that will result will have varying amounts of hemi-hydrate, anhydrite, ash, and possibly some sand, silt, and clay. In general, gypsum plaster sets very rapidly when mixed with water, so only small quantities should be mixed at a time and used almost immediately. Gypsum plaster will begin to stiffen in about five minutes and become completely rigid in under twenty. The addition of retarders can delay this process by as much as half an hour. Lemon juice, borax, sugar, molasses, fish liquor, and keratin (made from animal hoofs and horns) can all be used, and the actions of some of these are enhanced by a small quantity of building lime.

Once hardened, gypsum plaster is a hard and durable material, suitable for many building applications. In a wet environment, however, it will soften irreversibly and eventually dissolve. Portland cement or lime are often preferred as cements for outdoor use, as there is no easy way to improve significantly the water resistance of gypsum.

### Production processes

Gypsum processing plants vary widely in scale and level of technology. They range from plants producing one or two tonnes per day using low-cost manual technologies, to plants of a thousand tonnes per day that are highly mechanized and capable of producing different types and grades of gypsum plaster or plaster boards.

There are five basic stages in gypsum processing:

Excavation is sometimes carried out by digging out an area of ground where the gypsum is located using open-cast techniques. To reach deeper deposits drift or shaft mines may be needed.

Crushing the gypsum rock is advisable before processing further, especially if subsequent heating is to be done in a pan rather than a shaft kiln. Crushing will ensure a product which is more uniform and requires less energy to heat. Crushing can be done manually with a hammer or hand-held roller, but mechanical crushing is faster and less laborious. Most clay-crushing equipment, such as that used for brick-making and pottery, would be suitable. Crushing should reduce the gypsum to grains of less than a few millimetres across. Gypsum sand does not need crushing.

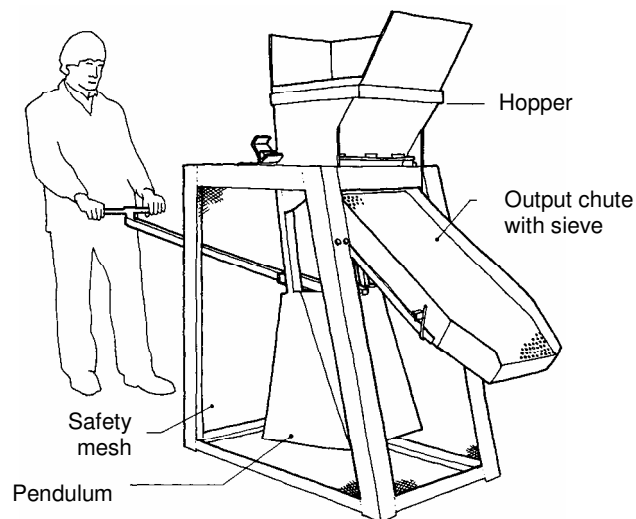

Figure 3: Crushing the gypsum ensures a more uniform product which requires less energy to heat. (This clay crusher was designed by J M Parry Associates Ltd.)

Screening with a sieve (manual or motor-driven) will remove large grains which have not been crushed properly and which may contain impurities.

Grinding, for example in a ball, rod, or hammer mill, is necessary if the gypsum is to be used for high quality plasterwork or for moulding, medical, or industrial applications. Unlike with other cements, such as lime and Ordinary Portland Cement, special mills for mineral grinding may not be required and the relatively soft gypsum could be pulverised in agricultural mills, which are generally widely available.

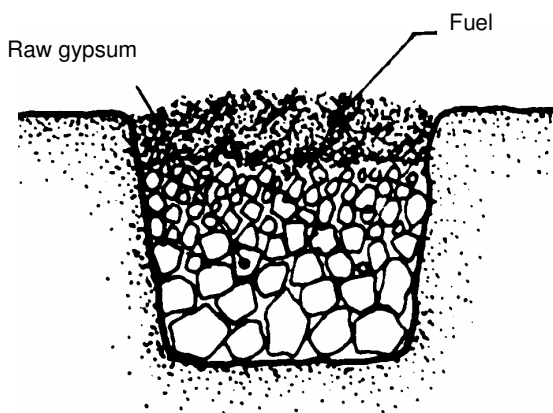

Figure 4: A pit kiln is the simplest method of heating gypsum, but it is inefficient compared with other methods

Heating may be done in a number of ways involving a range of technology levels and costs. The simplest method is to mix the gypsum stone and fuel in a mound or in a shallow pit in the ground and burn it. Medium-scale batch production might be carried out in an excavated hillside kiln, a shaft kiln with alternate fuel and stone layers, or a permanent walled kiln. An alternative method is to heat the gypsum in large pans or on a flat metal plate positioned above a kiln. Industrial production may be carried out in a purpose-built enclosed batch kiln, a continuously fed vertical shaft kiln, a specially designed large kettle, or in rotary kilns. Kiln-based systems

are more efficient than burning the gypsum in mounds or pits, and even a small kiln may use less than half of the fuel of a pit or mound.

It is easiest to judge when enough heat has been applied if an indirectly heated pan or metal plate is used. When the temperature of the surface is increased steam will be produced and the material seems to boil. The temperature is maintained until this 'first boil' is completed, which removes all but a quarter of the water, and leaves hemi-hydrate plaster. If the temperature is allowed to rise further this will start to convert to anhydrous plaster. Allowing the material to cool naturally after firing will help to remove some residual water left in the mass. It is also important to stir the material continuously to help the steam escape. If the material is heated in a kiln then it is more difficult to know when the removal of water has taken place, and fuel usage and loading would need to be judged from experience. As a rough guide, a field kiln might require 0.2 tonnes of wood for every tonne of raw gypsum burned, or 70 litres of fuel oil, although kiln efficiencies will vary widely and so would the optimum amount of fuel to use.

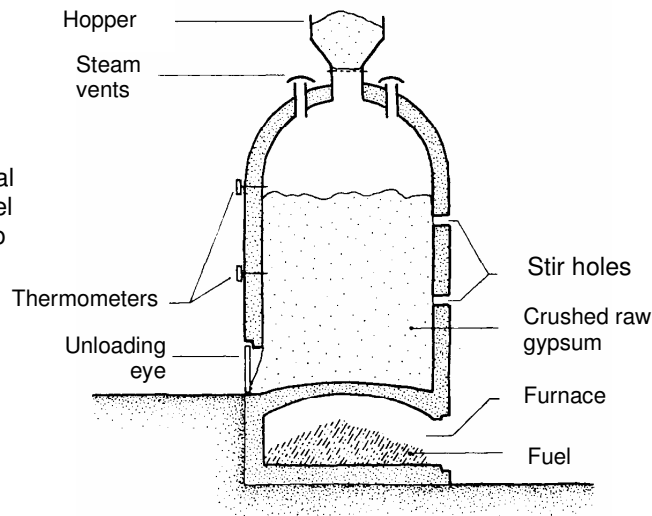

Figure 5: Even a small kiln, such as this hopper fed furnace-heated batch kiln, may use less than half of the fuel of a pit kiln

In some small batch kilns gypsum rock is burned in the form of lumps, with the larger lumps nearest the fire supporting the smaller stones further away. After burning, the gypsum would still need to be crushed, screened and, possibly, ground down further in a mill.

### Using gypsum plaster

Plaster of Paris is mixed with sand and water to produce a mix suitable for plastering walls and ceilings, for external rendering in dry climates, for mortar, and for making building blocks. It can also be used as a soil stabilizer in stabilized soil blocks. If mixed into lime-based plasters and mortars, it will give a fast initial set compared with the much slower-setting lime.

Gypsum-based mortars and plasters are typically made up of one volume of gypsum to two or three of sand, with enough water added to make the mix sufficiently workable. As the mix may start to stiffen only five minutes after adding the water, it is important to make up only small quantities of plaster and to apply these quickly, unless retarders are used. A typical mix for wall blocks would be one volume of gypsum plaster to one volume of sand, two volumes of gravel, and one volume of water. Such blocks would be hard enough to de-mould after 10 to 15 minutes, before being left to dry for several days. The blocks should satisfy the standard requirements for building blocks for general internal structural purposes, and not be used in wet or damp conditions.

Gypsum plaster can also be reinforced with fibres and cast in moulds to produce precast decorative panels.

Masonry cylinder 1 – 1.5m diameter

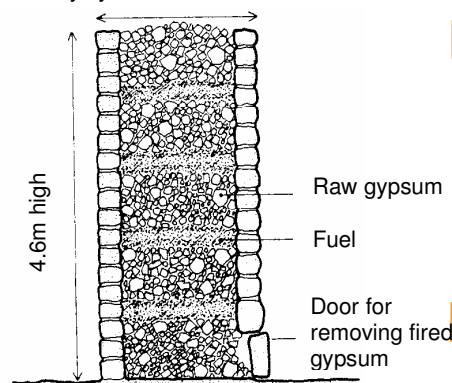

Figure 6: A Continuously fed vertical shaft kiln is an efficient way of processing large amounts of gypsum

technical brief

Certain fibres, such as sisal and conventional glass fibre, will not deteriorate appreciably in a gypsum medium, although they do deteriorate over time in a more alkaline Ordinary Portland Cement mix. Note that because of its affinity for water, gypsum plaster should be stored in a dry place, and never outdoors if there is a risk of rain. If storing gypsum in bags or in bulk for long periods then it should not be stored directly in contact with the ground and preferably raised on pallets or slats. Prolonged storage in damp or humid conditions is not advisable.

### FaL-G Bricks and Blocks

Gypsum is a significant ingredient in Fly ash – Lime – Gypsum (FaL-G) bricks and blocks that have been developed in India. These can be moulded with the same equipment used for conventional concrete bricks and blocks and cured in water or steam, in the same way as for concrete. Properties for the bricks and blocks similar to those of conventional concrete can be achieved and it is claimed that even low grade waste gypsum and lime can be used in the mixture to make satisfactory products.

### Reference and further Reading

- *Gypsum Plaster: Its manufacture and use*, Andrew Coburn, Eric Dudley, Robin Spence. IT Publications, 1989  
(A manual for potential and existing producers and users of gypsum, covering raw material identification, properties of gypsum, production and use. Summary information on a number of case studies from around the world is presented, and a glossary, selected bibliography and contact addresses are included.)  
Available from:  
Practical Action Publishing  
The Schumacher Centre for Technology & Development  
Bourton-on-Dunsmore  
Rugby  
Warwickshire CV23 9QZ  
United Kingdom  
Tel +44 (0)1926 634501  
Fax +44 (0)1926 634502  
E-mail: [publishinginfo@practicalaction.org.uk](mailto:publishinginfo@practicalaction.org.uk)  
Or order online from Development Bookshop  
Web: [http://developmentbookshop.com/product\\_info.php?products\\_id=42](http://developmentbookshop.com/product_info.php?products_id=42)
- *Guidelines for manufacture of gypsum plaster in Mechanized pan system (IS 13001: 1991)*, Bureau of Indian Standards
- *Low Grade Gypsum; Use In Building; Code of Practice (IS 12654: 1989)*, Bureau of Indian Standards  
Contact Bureau of Indian Standards for other relevant standards on gypsum  
Bureau of Indian Standards  
Manak Bhavan  
9 Bahadur Shah Zafar Marg  
New Delhi-2  
Ph: 23238821  
Email: [sales@bis.org.in](mailto:sales@bis.org.in)  
Web: <http://www.bis.org.in/bis/start.htm> (to search catalogue)
- *Small-scale production of gypsum plaster for building in the Cape Verde Islands*, Ray Smith, in *Appropriate Technology*, Vol.8 No.4, pp 4-6. IT Publications,
- *Construire en Platre*, Marc Nolhier. Editions L'Harmattan, Paris, 1986.  
(Comprehensive text on gypsum. Covers both production technologies and the use of gypsum in building. Many case studies included from around the world as well as a comprehensive bibliography. Only available in French.)  
Publisher - Editions L'Harmattan  
5 – 7 Rue de l'Ecole Polytechnique  
75005 Paris, France  
Internet: <http://www.harmattan.fr/index.asp?navig=catalogue&obj=livre&no=6472>  
Tel: 01 40 46 79 20  
Fax: 01 43 25 82 03
- For information on a small scale gypsum calciner and gypsum board manufacture

for dry lining of walls that has been developed by the Central Building Research Institute in India contact:

The Director

Central Building Research Institute (CBRI)

Roorkee – 247 667

Uttarakhand

India

Tel: +91-1332-272243

Fax: +91-1332-272272

E-mail: [director@cbri.in](mailto:director@cbri.in) or [director@cbrimail.com](mailto:director@cbrimail.com)

Web: <http://cbri.org.in/gypsum.htm>

- For further information on Fly ash – Lime – Gypsum (FaL-G) bricks and blocks contact the developers of this technology:  
Institute for Solid Waste Research & Ecological Balance (INSWAREB)  
Fal-G Mansion, 35 Shri Venkateswara Colony  
Visakhapatnam, 530012, INDIA  
Ph: +91 891 2516411  
Fax: +91 891 2517429  
E-mail: [inswareb@sify.com](mailto:inswareb@sify.com)  
Internet: <http://www.fal-g.com/>
- For basic information on production of school writing chalks from both limestone (calcium carbonate) and gypsum see:  
<http://www.madehow.com/Volume-1/Chalk.html>
- For information on the pendulum clay or soft rock crusher contact the developers:  
JPM Parry & Associates Ltd  
Overend Road  
Cradley Heath  
West Midlands  
B64 7DD  
UK  
Tel: +44 (0) 1384 569171  
Fax: +44 (0) 1384 637753  
E-mail: [info@parassociates.com](mailto:info@parassociates.com)  
Web: <http://www.parryassociates.com/online-catalogue/section14.htm>

# technical brief



For further information contact:

**Practical Action**

The Schumacher Centre for Technology & Development  
Bourton on Dunsmore, Rugby CV23 9Z,  
United Kingdom  
Tel: 44 (0) 1926 634400  
Fax: 44 (0) 1926 634401  
E-mail: [infoserv@practicalaction.org.uk](mailto:infoserv@practicalaction.org.uk)  
Website: <http://www.practicalaction.org>

**Basin**

The Building Advisory Service Information Network



Website: <http://www.basin.info/>

This technical brief was originally written by Otto Ruskulis for the *Appropriate Technology* magazine Volume 23/Number 4 June 1997 ATBrief No 19 and updated in March 2008.

For more information about *Appropriate Technology* contact:

Research Information Ltd.  
222 Maylands Avenue  
Hemel Hempstead, Herts.  
HP2 7TD  
United Kingdom  
Tel: +44 (0)20 8328 2470  
Fax: +44 (0)1442 259395  
E-mail: [info@researchinformation.co.uk](mailto:info@researchinformation.co.uk)  
Website: <http://www.researchinformation.co.uk>

*This Technical Brief is possible thanks to the collaboration of DFID-UK and The Tony Bullard Trust.*

technical brief