

Oxfam Water Supply Scheme for Emergencies

Instruction manual for

Water Distribution Equipment

Covering layflat, PVC and PE pipe kits



An Oxfam Technical Manual

H

Humanitarian Department

Oxfam Water Supply Scheme for Emergencies

This equipment is part of several packages devised by the Oxfam Public Health Engineering Team to help provide a reliable water supply for populations affected by conflict or natural disaster. The equipment is designed to be used with any or all of the following Oxfam water equipment: Water Storage equipment, Water Coagulation and Disinfection equipment, Water Filtration equipment, Water Pumping equipment, Well Digging equipment, and Water Testing Kit. All are designed using available, easily transported equipment which is simple, rapidly assembled, and fully self-contained, to provide an adequate, safe water supply at moderate cost. The principles used in these packages may often be useful in long-term development projects.

The Oxfam equipment packages, which consist of “Oxfam” tanks (steel sheets, rubber liners), diesel water pumps, 3” PVC pipes etc, have been used successfully in the last two decades in often harsh environments, ranging from tropical to temperate climatic areas. Although this equipment is designed for emergencies, if installed and protected adequately it can give many years of useful service, though some up-grading works will be necessary to prolong its life. This equipment can be dismantled and re-used elsewhere.

However, these Oxfam equipment packages, while being simple to erect over a period of days, yet durable enough to last several years, do not lend themselves to very rapid deployment in a few hours. Increasingly, the nature of work which Oxfam has been called on to undertake has required equipment that can rapidly deployed then dismantled and moved to other locations. This has led to the development of the so called “rapid response kits” since the mid-1990s. This type of equipment is seen as a necessary complement to the original Oxfam equipment and is best used to provide a start up package in the absence of a detailed assessment and where affected populations are likely to be highly mobile. The relatively higher equipment costs and lack of suitability for anything other than short term water supply means that the deployment of the “rapid response kits” should be used only where appropriate.

Read this manual through before starting installation.

Contents

SECTION A - EQUIPMENT USE AND SYSTEM DESIGN	2
Types of pipe and fittings	2
Design criteria	3
SECTION B - LISTS OF KITS AND INSTRUCTIONS FOR USE	8
Water Distribution kits	8
Installation instructions	9
SECTION C - OPERATIONAL INFORMATION	16
SECTION D - DETAILS OF KITS AND SUPPLIERS	18
Full list of kit contents	18
List of suppliers	20
Final reminders and recommendations, references and acknowledgement	

SECTION A - EQUIPMENT USE AND SYSTEM DESIGN

The Distribution equipment is designed to deliver water to users from Oxfam Storage equipment or any other suitable storage facility. The 90mm (nominal 3") pipe can be used for pumping and distribution mains, while the 63mm PE pipe coils can be used for smaller distribution and pumping mains or for branches to 90mm mains. Where possible, water should be distributed by gravity from storage tanks, which may be achieved by siting the storage tanks at the top end of a gently sloping site or on a local point of higher elevation, and by designing the system to keep head losses to a minimum. Where this is not possible, the equipment is designed to be used also with the Water Pumping equipment, for a pumped distribution system.

The package of equipment comprises distribution main kits, distribution stand kits complete with 6 No. Water saving valves, distribution pipe, and a distribution fittings kit. A distribution adaptation kit is also provided, with a range of fittings that allow the Oxfam 90mm (3") system to be connected into other agencies' kits, water trucks, and existing water supply systems.

Types of pipe and fittings

There are several different pipe types used by Oxfam, found in different kits and used in different ways.

1. Layflat hose is the pipe most recently used by Oxfam in its emergency response and is included in distribution/layflat rapid fittings kit (Oxfam code DLR). 75mm diameter layflat hose (fire hose) is provided in the kit, which is compact, easily transported and quickly laid out, though is only suitable for short term use, as the pipe is not as strong as rigid wall pipe systems, it has higher head losses and cannot be buried in trenches. Thus the DLR kit should usually only be considered for use with the rapid response bladder and onion tanks.

2. 90mm diameter UPVC main (pipe with wall thickness of about 4mm, made of a fairly rigid

plastic), using simple push-fit joints. UPVC is much cheaper to buy and freight, is easier to purchase locally, and has the advantage of incorporating couplings as an integral part of the pipe. However, it does need burying immediately as the joints have no end load resistance, it is relatively brittle and easily damaged and degrades in sunlight. Thus it is not suitable for use in very rocky ground or on roads and pavements where trench excavation is not possible.

3. PE main (pipe with wall thickness of about 10mm for 90mm diameter pipe, made of a softer plastic) joined either by using compression couplings or by butt fusion (heat) welding. PE pipe comes in 50m or 100m coils, or in straight lengths, usually 6m, but 4m can be specified. However coils of 90mm pipe are about 3.0m in diameter, which makes air freighting very costly and in some areas moving coils this size by truck is very difficult. Straight lengths on the other hand require purchase of numerous compression couplers or butt fusion welding equipment, which are either expensive to buy or slow to make. Thus the use of PE is usually restricted to 50m length coils of 63mm diameter pipe (1.7-1.9m diameter, weight 25kg) which can be laid out quickly and used to extend branches from the distribution main a long way into the community.

4. 3" low-pressure rated green flexible hose, which is used for some pump suction and delivery hoses, and making connections into tanks. For the 4" pumps, some 4" hose is provided for suction pipe and some higher-pressure hose for delivery pipe.

For very large populations it may be more appropriate to order either 110mm or 160mm PVC, for which specifications have been prepared, but not included in this manual.

Various sorts of valves are used in the Oxfam kits and a brief explanation of each is given below:

1. Gate valves operate by a simple wind up and down "gate", and these are used throughout the kits as flow isolators.

2. Globe/ball valves are used with some of the pump and other kits and can be used for flow control as well as isolation, where flow may need to be adjusted to suit requirements.

3. Non return/check valves only allow flow in one direction, particularly used in the pump kits, e.g. foot valves used at the end of a suction hose to stop it emptying when not in use.

4. Float valves automatically maintain the water level in a tank by closing up when a tank is full, which is useful to prevent accidental overfilling. While they are included as part of the SSF kit, these valves have to be ordered separately if required elsewhere in a system.

In addition two other valves and water meters may be ordered if required:

5. Air valves, which are usually placed at high points in a pipeline to allow accumulated air trapped in a pipe to escape and to let it enter when a pipe is emptying. Ferrules straps could be used as a manual air bleed point in the short term, but an automatic air release valve should be ordered if required. The Oxfam code G3.37, is a 6 bar rated valve, used in conjunction with a ferrule strap on a 90mm pipeline, which needs to be installed in a vertical position.

6. Pressure reducing valves reduce pressure in a pipeline, and may be required where gravity supply from a tank to tapstands at the bottom of a hill creates too much pressure in the taps. Pressures higher than about 2 bar in tapstands cause flows to be excessive and the Talflo taps are hard to open and “kick” when operated. While adjustments on the ferrule strap and gate valves fitted to the branches can provide reduction in flows, they do not reduce the static head on the tap and are thus not recommended solutions as taps are difficult to open under high pressure. The Oxfam code G3.39, is a 3” class T pressure reducing valve, costs about £500 and is available to be placed on the 90mm diameter mains and provides a pressure reduction between inlet and outlet of the valve of;

3 bar	for flow of 13l/sec
20 bar	for flow of 18l/sec

7. Water meters, which measure cumulative water flows, can be useful to monitor system production when installed at pump/tank outlets, though at a cost of about £350- its purchase needs to take this into account. The Oxfam code G3.38 is a Helix 3000 bulk water meter rated to 136m³/hr (head loss 4.2m), supplied with flanges to join to 3” BSP threads.

Design criteria

The move towards production of metric pipe means that Oxfam now uses metric pipe for both PE and UPVC, though threaded galvanised pipe is still available and specified in imperial sizes. Metric pipe has slightly different pressure ratings from imperial pipe, but still comes in a variety of different maximum working pressure ratings. While the 63mm PE pipe is only available in 12.5 bar (SDR11, PE80), the 90mm PE pipe is manufactured in several ratings, of which the following may be useful 8 bar (SDR17, PE80), 12.5 bar (SDR11, PE80) and 16 bar (SDR11, PE100). 90/110/160mm UPVC pipe is available in the same pressure ratings. The pipe and fittings used in the Oxfam kits have a minimum 8 bar rating. Where 8 bar pressures will be exceeded, this should be made clear in the equipment order.

It should be noted that the maximum pressure rating for UK manufactured pipe is for a design life period of 50 years and actual pressure at failure is over twice the rated pressure, so there is some margin for safety if pipe is pressured beyond its rating. However, this probably does not apply for pipe manufactured in developing countries, as water industry standards (if they exist) are less demanding and production quality control is likely to be poorer. **Thus where it is proposed to purchase pipes locally, it is suggested that in the absence of proof of pipe quality, that the next pressure rating up is used, i.e. use 12.5 bar pipe where system pressures will reach 8 bar. Where locally procured compression couplers are used, these should be dismantled when jointing pipes to ensure full depth insertion and inserts may be required for locally procured pipes 90mm or larger, as compression couplers may otherwise squash the pipes on tightening.**

As a minimum, SPHERE recommends a figure of 15 litres/person/day and one outlet (tap) per 250 people (assuming a minimum flow of 0.125l/sec can be achieved). However, as this is a minimum and may lead to considerable queues developing at peak times (early morning and late afternoon/evening), it is suggested that one tap per 200 people with a flow of 0.2 l/sec for each tap, i.e. 1.2l/sec per tapstand (each tapstand having 6 taps) is used. SPHERE recommends that no dwelling should be further than 500 metres from a water point. (UNHCR recommends the figure of 100 metres, which is difficult to achieve and can promote too much disparity between the affected population in the case of refugees and the surrounding host population in rural areas.) However, these are minimums for guidance and different situations may demand different standards.

The Oxfam distribution stands are fitted with six self-closing Talflo taps. Each Talflo tap will give the following flows for the given heads:

Flow (l/s)	0.05	0.12	0.2	0.38
Head (m)	0.1	1.0	3	10

Where possible, layout of the system and pipe diameters should be chosen to give about 0.2 litres/sec, requiring a residual head of around 3 metres at each tap. If the rate is greater, water may be wasted; if it is less, long queues may form at distribution points. Where flat sites don't permit a 3m head at each tapstand, for design purposes the numbers of people using tapstands should be reduced from 1200 to a lower number.

It is assumed that the reader has a basic understanding of water-distribution system design; hence only head-loss tables and two short examples are included below. ***If this is***

completely new to the reader or more complex system analysis needs to be undertaken, they should refer to texts that have more detailed information such as Gravity-flow Water Systems (Jordan) or Engineering in Emergencies (Davis/Lambert).

Worked design examples and head-loss tables

Though the kits have predetermined pipe sizes, there is some choice in the way these are used and some simple design checks should be undertaken. Where possible, a survey of the site should be made and the results used to make a simple check on what pipe size should be used, and whether it is strong enough to withstand the pressure. The survey should measure height difference and distances between the reservoir/pump and distribution stands/water treatment works.

Head (friction) losses in pipes and secondary losses in fittings must be taken into account in order to estimate how much water will flow in a particular system. The head losses in pipes can be estimated using head loss tables (included here) or by calculation (not shown here). In very short lengths of pipe the secondary losses at inlet, outlet and valves will be significant and must be taken into account. Note that the two examples below do not take into account head losses in fittings, though estimates for these are given at the end of the examples. Pipe velocity should also be checked at this stage, using the head loss tables and it is desirable to have flow velocities between 0.7m/s to 2m/s, outside this range allows sedimentation of particles or abrasion of pipe by particles.

Gravity flow design

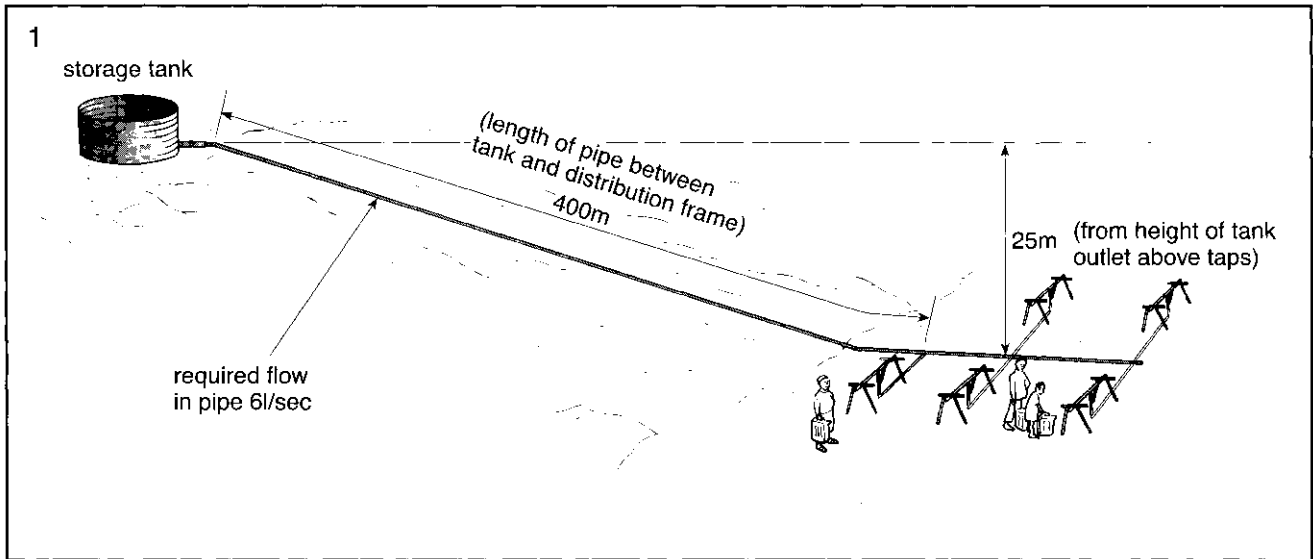

1. An Oxfam tank needs to supply water by gravity to 5 distribution frames at the bottom of a hill. What pipe size is required?

$5 \text{ (distribution frames)} \times 6 \text{ (taps for each frame)} \times 0.2 \text{ litres/sec (at each tap)} = 6 \text{ litres/sec}$ (required flow at bottom of hill)

3m residual head is required to give the desired 0.2 litres/sec for Talflo taps; therefore acceptable head losses in pipe are:

$25 \text{ (height difference)} - 3 \text{ (required residual head)} = 22\text{m}$ over 400m of pipe i.e. head loss of 5.5m/100m.

Using the head-loss chart, read off the pipe size where the required flow rate (6 litres/sec) intersects with the head loss: 5.5m/100m. This lies between a 63mm and 90mm PE pipe, so choose the nearest pipe size up, i.e. the 90mm pipe. This would give a flow velocity of about 1.65m/s, which is between the desirable 0.7 – 2.0m/s, so would be acceptable.

For gravity flow systems, pressure on the pipe is at its greatest at the tap and when taps are closed and is equal to the static head, i.e. $25\text{m} = 2.5 \text{ bar}$. This simple check should be used to establish that the pipe pressure rating is adequate to take the static pressure head.

Pumping main design

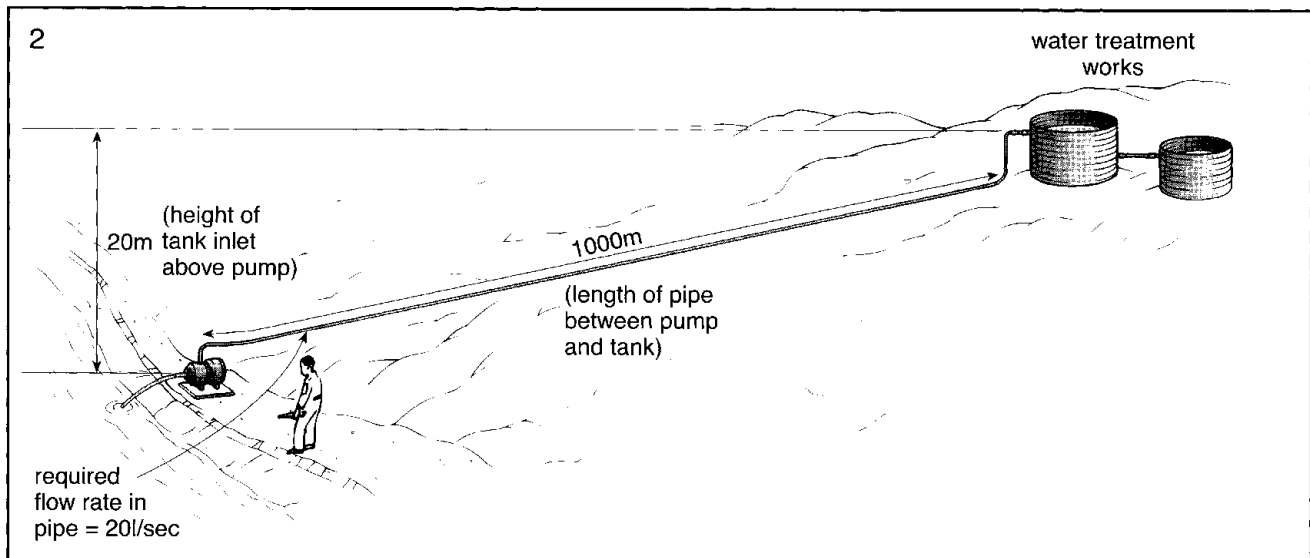

1. An Oxfam water-treatment works need to be supplied by a pump with 20 litres/sec. An Oxfam P4H pump is available for use, which has a Total pumping head of around 42m for a flow of 20l/sec (at sea level and running at 2,200rpm).

Total pumping Head = Static head + pipe friction losses + secondary losses (not included)
 42 (Total pumping head) – 20 (height difference)
 = 22m max HL over 1000m.

i.e. the head loss can be no greater than 2.2m/100m in order to achieve this flow.

Using the head-loss chart, read off the pipe size where the required flow rate- 20 litres/sec – intersects with the head loss – 2.2m/100m. This lies between a 110mm and a 160mm UPVC pipe, so choose the nearest pipe size up, i.e. the 160mm pipe; or alternatively two lines of 110mm pipe or 4 lines of 90mm could be used in parallel, if no 160mm pipe is available. This would give a velocity of 1.35m/s where four 90mm pipes were used in parallel (assume each takes $\frac{1}{4}$ of the flow), which is between the acceptable range of 0.7 – 2.0 m/s.

Pressure developed in the pipe at the pump would be 42m, i.e. 4.2 bar, which is well within the pipe pressure rating.

Given below are very approximate head losses in metres for various plastic fittings, based on a pipe velocity of about 1.5m/sec.

Sharp 90° elbow	15 x pipe Ø (m)
Tee (perpendicular to flow)	15 x pipe Ø
Tee (aligned to flow)	6 x pipe Ø
Foot valve/strainer	40 x pipe Ø
Gate valve	3 x pipe Ø

(Galvanised steel (GS) pipe and fittings have higher head losses for the same flow of water).

Storage of materials

UPVC is not stabilised for ultra-violet (UV) light in direct sunlight, so pipes should be kept covered while in storage and buried once laid; otherwise they quickly become brittle. To avoid distortion in storage, they must be well supported along their full length. Screwed plastic fittings will easily become jammed and almost impossible to open, even after cooling, if left in direct sunlight or high temperatures. This may be avoided by storing all plastic fittings in a water-filled container when working in hot areas. PE pipe comes in two types: blue for below ground use and black for above ground use, though in practice both types are resistant to UV light to several years. (Note that black pipe absorbs a lot of heat when laid above ground, which could lead to problems with joint pull out when contracting after filling with water). Pipes should be stacked carefully to avoid distortion, especially ovaling; stack heights should not exceed 1.5 metres for 90mm pipes, 1.2 metres for 110mm, and 1.8 metres for 160mm.

Head loss diagram for PE and UPVC pipe

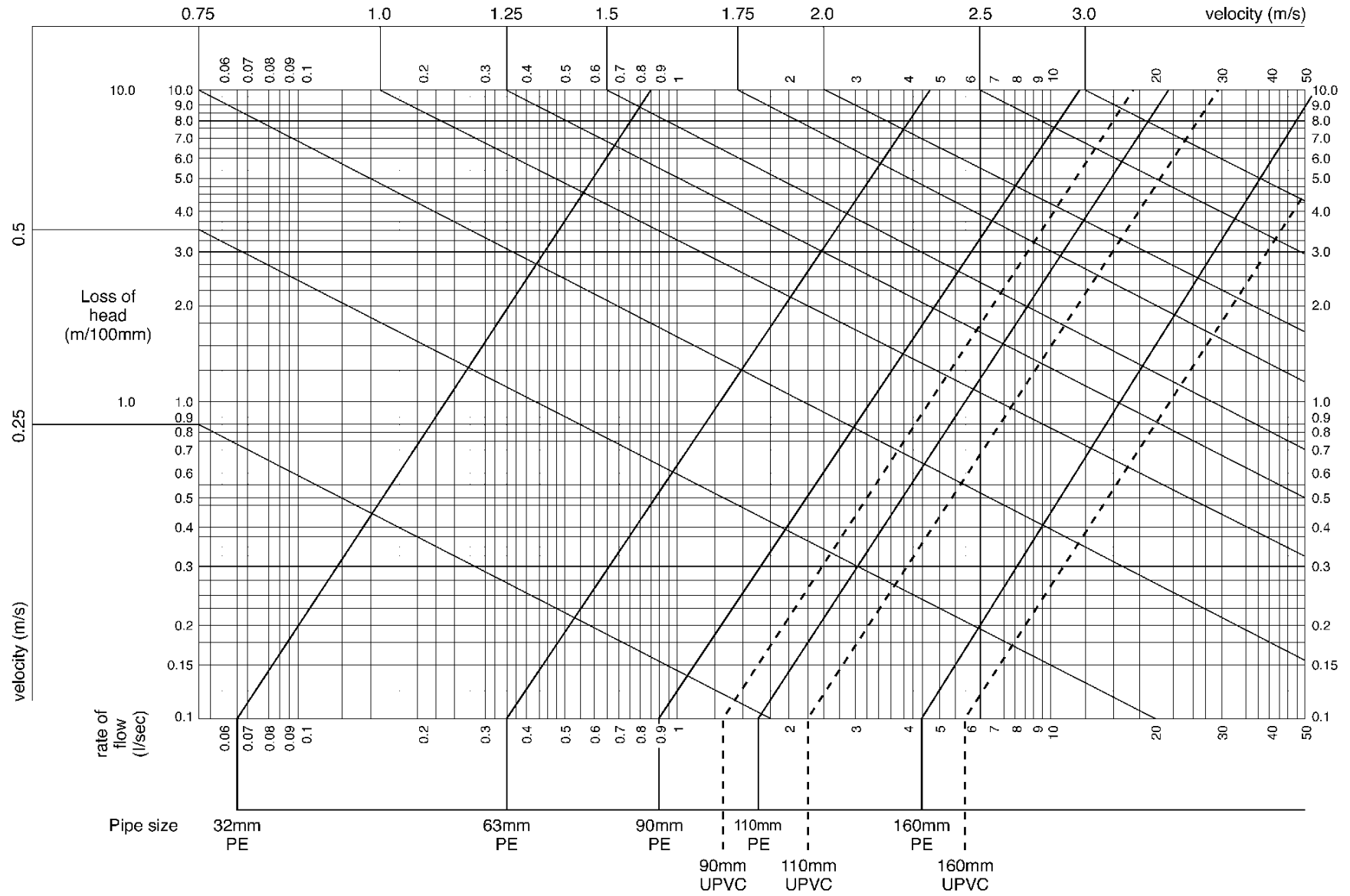

SECTION B – LIST OF KITS AND INSTRUCTIONS FOR USE

Water distribution kits

The package of equipment consists of the following kits, which should be ordered as required each with an identifying code number on the crate or box. Typical quantities for 1200 people would be: 32mm distribution pipe – 2 rolls: distribution stand kit – 1: distribution frames - 8. The DF3 kit has enough fittings for 4 branches of 63mm pipe to be connected to a 90mm main, with 63mm to 32mm reducers and 32mm Tees to enable 2 distribution stands to be connected to the end of each branch. The quantity of 90mm and 63mm pipe required for main pipeline(s) will depend on the length required for pumping and distribution mains.

This manual explains how to use/erect the following kits (detailed kit lists are provided in section D):

Oxfam code	Description
DMU3	90mm (nominal 3") UPVC Distribution main kit, 504m
DF3	90mm (nominal 3") UPVC/PE Distribution fittings kit
DPP2	63mm (nominal 2") PE Distribution main/pipe kit
DP	32mm PE distribution pipe
DS	Distribution stand kit
DA	Distribution adaptation kit
DLR	Distribution Layflat/rapid fittings kit

In addition specifications have been prepared for other kits which are much less often used, and though not stocked by Oxfam or their use explained in this manual, they can be ordered if required.

Oxfam code	Description
DFU4/2	110mm Ø (OD) Distribution Fittings Kit for HEP ₃ O and uPVC pipe
DFU6/2	160mm Ø (OD) Distribution Fittings Kit for HEP ₃ O and uPVC pipe
DMP3/2	90mm Ø (OD) PE Distribution Main Kit, 500m in coils
DMU4/2	110mm Ø (OD) Hep ₃ O Distribution Main Kit, 500m
DMU6/2	160mm Ø (OD) Hep ₃ O Distribution Main Kit, 500m

Installation instructions

Layout options for pipework

3. Where possible, natural ground slope should be used to achieve a gravity flow, with sufficient head available at each distribution stand. Pipelines should be laid as near as possible to a continuous slope. In hilly areas, where high points can give rise to air locks, it may be necessary to install ferrules or automatic air vents (there have to be ordered separately); or collection points may be arranged to act as natural venting points. Sometimes the ground slope is such that there may be large differences in height between the tank outlet and the lowest distribution stand, and pressure-relief valves (not supplied in the kit) or a break-pressure tank may have to be used.

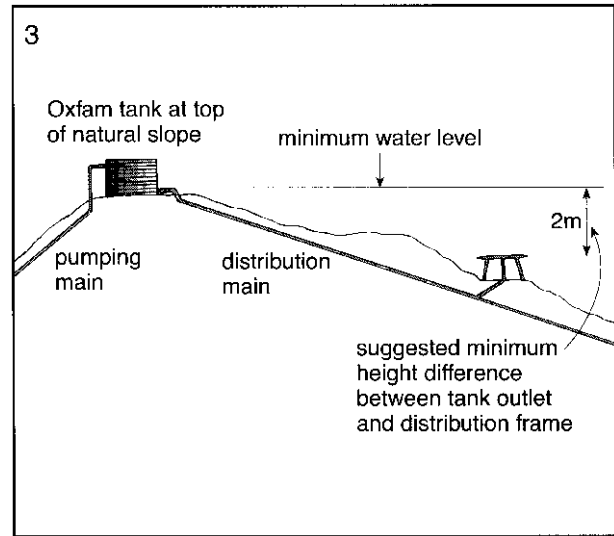

4. Where the ground is flat, gravity flow can be increased by elevating the storage tanks. A compacted earth mound can be constructed by building soil up to 2m in height. For temporary works, use of hemp/plastic grain sacks covered with plastic sheeting will help to stabilise the sides of the mound, though permanent installations should use concrete or masonry walls to stabilise the soil core. Ideally the sides of the mound should be inclined at no more than 45°, and there should be at least 1.0 metre from the inside edge of the sacks to the tank sheets, to allow for working room as well as mound stability.

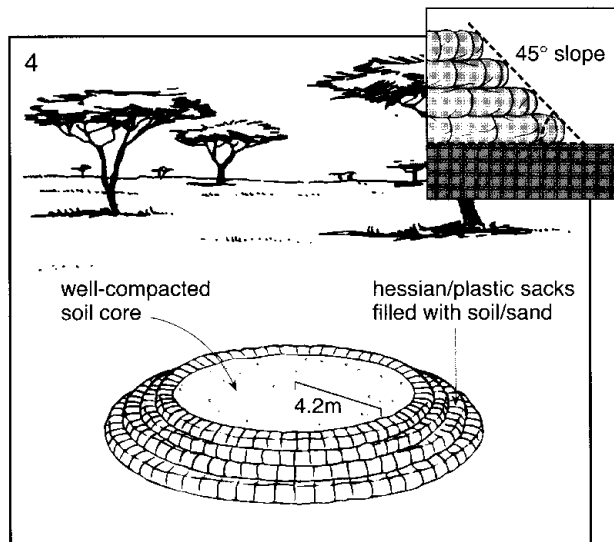

Where gravity supply is not possible, Oxfam can supply a pump for a pumped distribution system, which should be used only as a last resort. This will require supplies of diesel fuel and a local ability to service and run small diesel-powered pump sets. It is therefore much more complicated to run. For details, see the Oxfam Pumping equipment Manual

5. The DLR kit, with its layflat hose is designed to be used for up to 4 bladder or onion tanks and five tapstands and contains enough fittings to enable tanks to be set up at one or more locations. The 75mm layflat hose is best used for delivering water from a pump to storage tanks, while the 2" green flexible hose is best used for connecting tanks to tapstands.

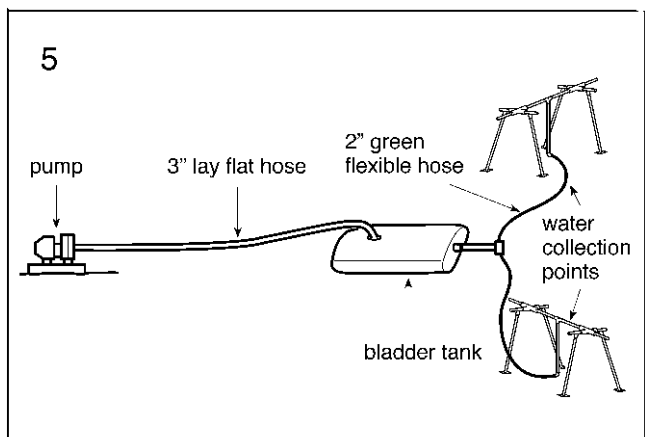

6. A simple branched distribution main is often used, as it provides the best access to the water points for the pipe available. The length and number of distribution stands should be determined by the needs of the population, but within the constraints of ground slope and pipe availability. Where high flows are required, more than one line of 90mm \varnothing main may be used, or alternatively 110mm \varnothing or 160mm \varnothing pipe may be ordered. In all cases, the 32mm or 63mm \varnothing branch pipes may be located at any point on the main, but the length of the branch should be limited to 10m for the 32mm pipe and 50m for the 63mm pipe, where the lack of pressure head is a problem, in order to keep friction losses to about 0.5m for 1 tapstand with a flow of 1.2l/sec. A capped outlet should be provided for drainage, and the strainer should be installed at the inlet to the main.

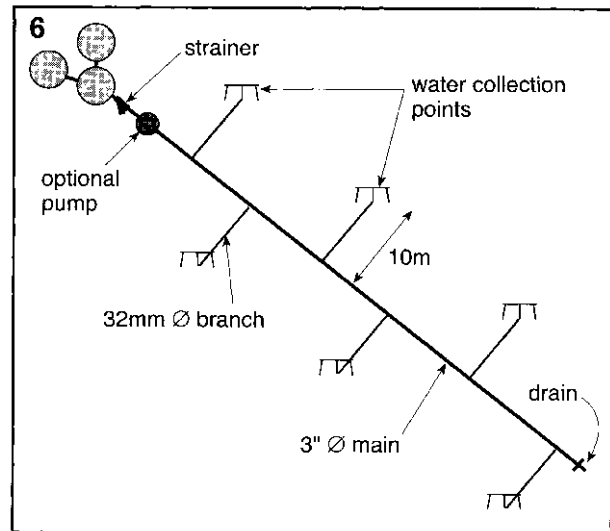

7. Alternatively, the use of a ring main may be considered, as this allows flow in both directions and thus gives water at all collection points even when blockages arise. This arrangement also produces the lowest friction losses. The minimum radius of curvature of the 90mm \varnothing UPVC pipe is 15m.

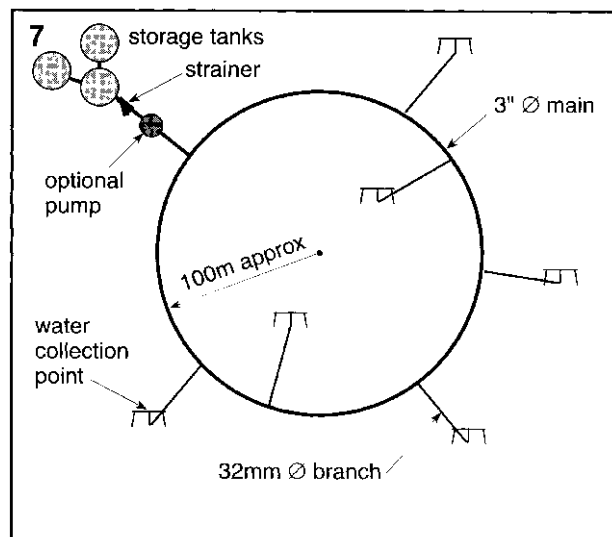

Installation of pipework

8. The UPVC pipes should be buried, in order to prevent damage and keep the water cool. Having determined the overall system layout, and thus the positions for the various pipe runs, mark out trenches in straight lines, using a piece of rope and pegs and sight poles if required. For permanent installations and where the pipe is to be used for a high-pressure pumping main, it is better to dig the trench 600mm deep to give more protection and prevent the pipe lifting under pressure. Pipe ends should be plugged with paper or cloth in order to avoid any possibility of blockage with soil or other matter. Remove any sharp stones from the trench, as they could damage the pipe. If the base of the trench is very rough, it should be leveled with a layer of sand to protect and support the pipe. Pipes should be fixed securely at any points where fittings are used, especially where these are under pressure, either above ground or

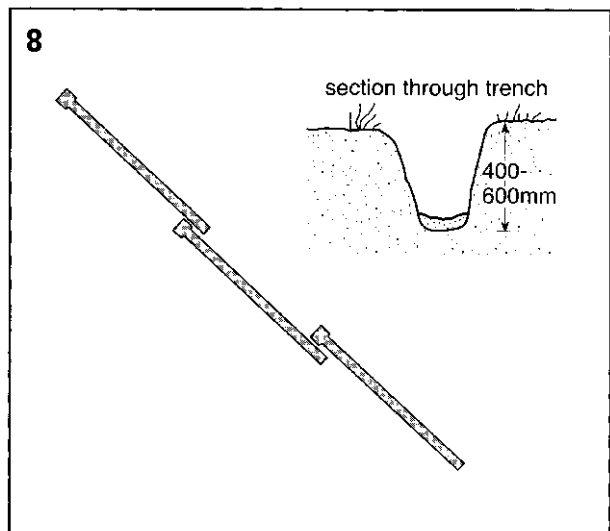

below ground. This can be done initially by using wooden stakes and later by casting a concrete block around the pipe, which prevents joints opening under pressure. Construct special protection where vehicles may pass over the pipes, preferably by providing a concrete covering over the pipe, or installing it at twice the depth. Excavation rates for experienced workers are typically 2.5m³/per/day for hard ground and 5 m³/per/day for soft ground, though these rates may need to be adjusted according to actual experience.

9. Starting from the storage tank, lay the pipes in the trench and make the push-fit joints as follows:

Inspect spigot end of pipe for damage, cut off and reform chamfer if badly damaged.

Ensure that the rubber ring is correctly seated in the socket and is undamaged. The ring will not seat properly unless inserted in the correct direction (face marked 'front' towards outer end of socket). If necessary, replace it with a spare ring.

Remove any plugs from the pipe-ends and ensure that the pipe bore is clear.

Clean both spigot and socket thoroughly and lubricate both with a little of the special lubricant provided, or with soap if no lubricant is available. Do not use grease, as this will damage the rubber ring.

Push the spigot into the socket until the ring is reached. Push firmly past the ring, holding both pipes securely. It may be necessary to tap the end of the pipe with a hammer; if so, protect the pipe-end with a block of wood. Twisting the pipe will also help entry into the socket. Ensure that the joint is fully made, by checking that the mark on the spigot is aligned with the end of the socket.

When the pipeline has been completed, backfill with a covering of soil over the length of the pipe, to protect the pipes from damage by sunlight – except for the joints, which should be left, exposed. Once the joints have been tested for water tightness (see Section C on commissioning), complete the backfilling. If pipe

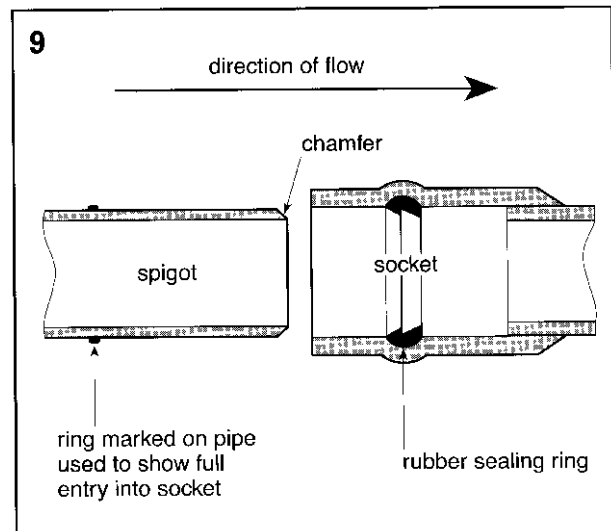

has been jointed in hot sunlight, it may contract later, when temperatures drop at night-time, or when cool water is pumped round; the contraction may cause some joints to pull apart. If this occurs, it will be apparent when testing the pipes for water tightness.

10. Where a distribution or pumping main has to be built quickly, 63mm (and larger) PE pipe coils can be unrolled and laid directly on the ground, without digging a trench. Coils should be placed at the highest end of the pipeline. Then the coil straps should be cut one at a time, starting at the end of the pipe, taking care that the pipe does not spring out when the straps are cut. Next, unroll the pipe, by holding one end in place and rolling the rest of the coil down the hill like a wheel. At a later date, when time permits, a 400mm deep trench can be dug next to the pipe, and the pipe can be laid in it and backfilled.

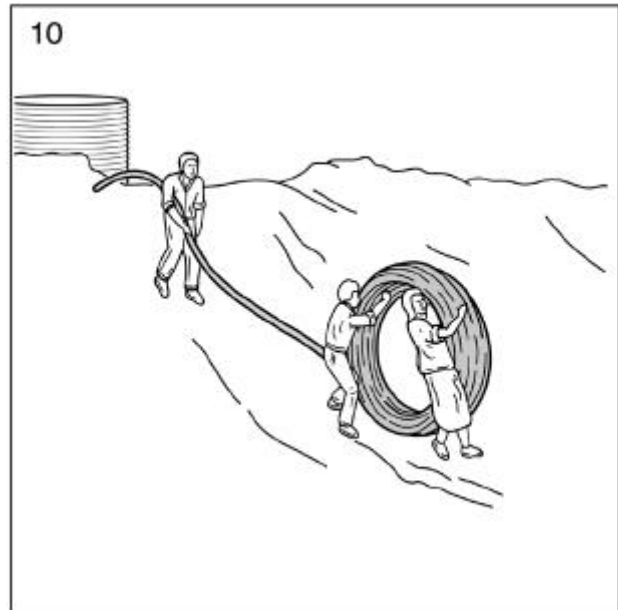

11. The coils of pipe can be joined by using compression fittings. It should not be necessary to take the compression coupling apart when making the joint. Simple clean and lubricate both pipe and coupling, and loosen the coupling. Push the pipe in until it has reached the back of the coupling. Make sure that it is well past the rubber ring. It is also important to have the ends of each length of pipe lined up well, so that they go squarely into the compression fitting; otherwise there will be a tendency to leak. However if difficulties are encountered, the coupling can be dismantled to make the connection.

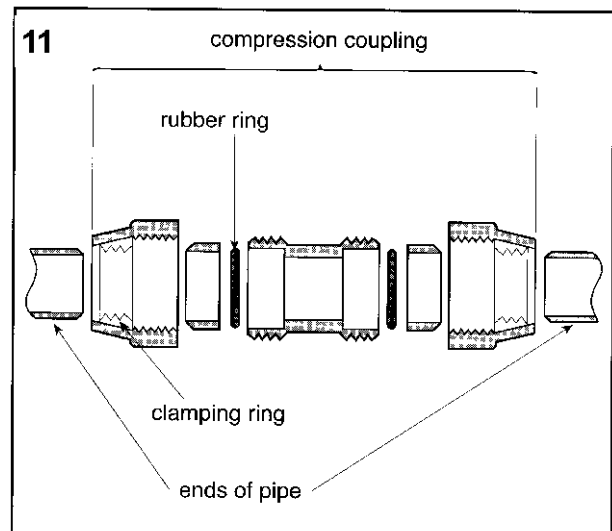

12. The flange and gate valve are supplied with the Water Tank Fittings Kit. The other fittings (the hex nipples, strainer, hose connector, and clip) are part of the Distribution Kit, Oxfam Code DF3. Connect the strainer next to the tank outlet gate-valve and connect the strainer to the pipe by means of the flexible hose, which will allow for any relative movement between pipe and tank. The hose may also be used to make changes in direction in the pipeline. The hose is connected and a male thread to compression joint coupling (see Figure 12). As this hose has a pressure rating of only 2 bar, it should not be used in situations where this is likely to be exceeded

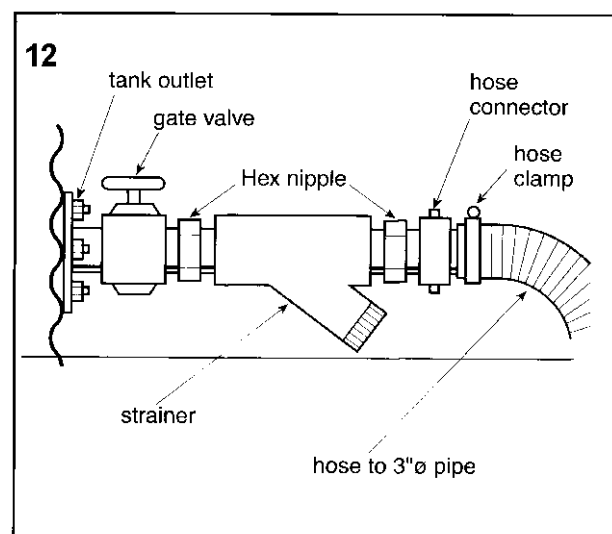

13. Compression joints are used to connect the pipe to threaded fittings and these are fitted as in (11) above. Make all metal threaded joints with PTFE jointing tape and tighten with strap wrenches. Do not over-tighten plastic threaded joints.

14. Where pipes are under high pressure, thrust blocks are required to resist movement due to unbalanced forces where changes in direction and diameter occur and where valves and junctions are used. These should be cast in concrete, which offers both mass to resist the thrust and allows a tight fit against the pipe to prevent any movement. Thrust blocks should be used particularly where UPVC pipe push fit joints are likely to come apart.

Water-distribution frame and branch connections

Water-distribution points are very prone to becoming muddy from water spillage, which could constitute a health problem and be inconvenient for users. Particular care needs to be taken to ensure that this problem does not arise. The first step is to ensure that the frame is well sited, preferably on higher ground and on a slope, to encourage good drainage. Then the appropriate location to make the connection on to the main can be selected. Where pipe quantity/technical considerations dictate that distribution stands have to be grouped together, preferably no more than two should be positioned at one location. Large groupings of distribution frames do not encourage good community use and management of water-collection points. Ideally the community should be consulted on this matter, because the distribution point is the end-user point.

15. Make 32mm or 63mm \varnothing branch connections with 10m or 50 metres (respectively) of pipe by using ferrule straps, which may be located anywhere along the main pipe. Assemble the two halves of the ferrule strap around the 90 mm \varnothing pipe, with the outlet at the top. Ensure that the rubber seating o-ring is located in the groove around the ferrule inlet. Clamp securely to the pipe. Unscrew the plastic cap and screw the cutter down through the wall of the UPVC/PE pipe, using the square-ended key

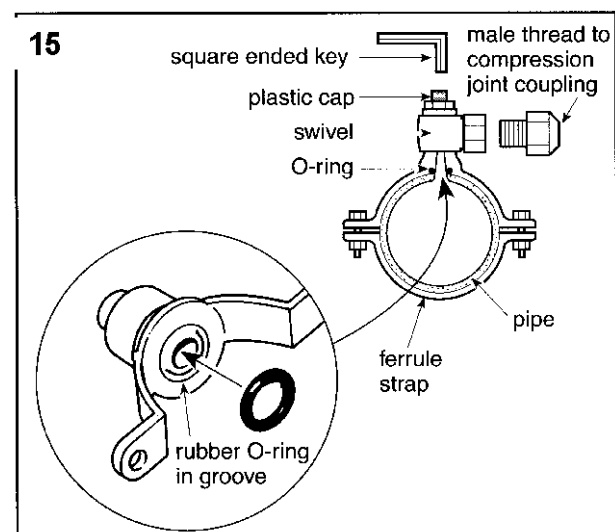
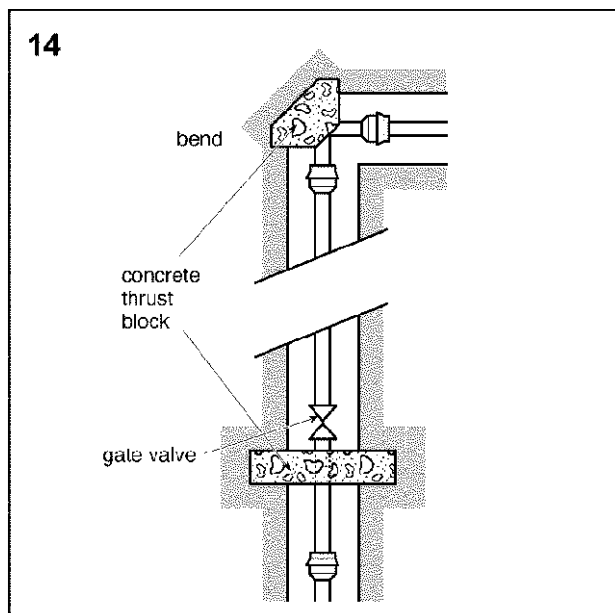
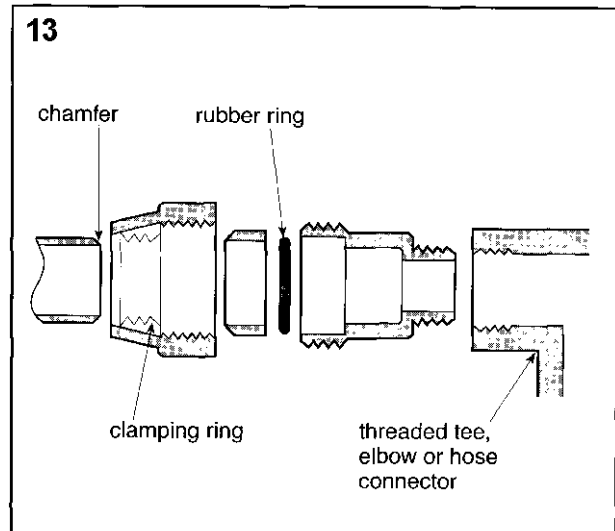

provided. Withdraw the cutter to the stop in the assembly. The cut piece of UPVC/PE will be retained. Ensure that the swivel assembly is tight and that the outlet is pointing in the correct direction. The 2" Ø BSP (M) x 63mm Ø UPVC compression coupling can be screwed into the ferrule strap outlet.

16. Place the distribution stand upside down on the ground; screw the four legs into the sockets and tighten with a wrench, so that the base plate is pointing away from the frame. Screw the 1" GS down-pipe into the centre of the distribution stand from the underside. Turn the distribution stand the right way up. Screw the six 3/4" extension pieces into the frame.

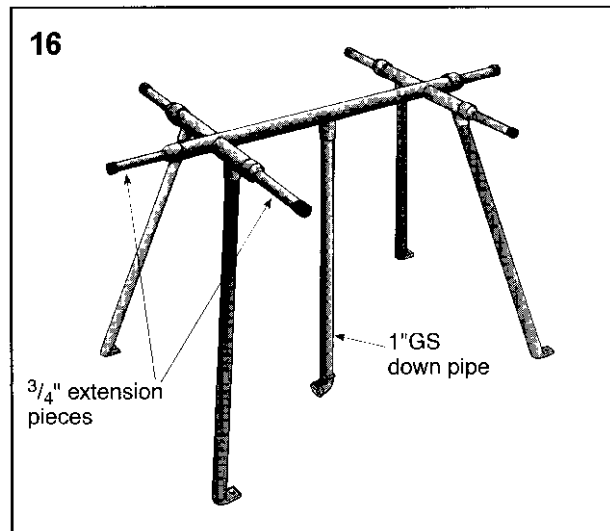

The other end of the 1" down-pipe is already attached to the 1" galvanised 90° elbow. The 1" ØBSP (M) x 32mm Ø UPVC compression coupling can be screwed into this elbow, after which it can be fitted to the flexible plastic pipe.

Where the distribution stand is positioned on existing hard surfaces, such as concrete, the extension piece for the down pipe is not required, but where pipes need to be dug in, then this should be used.

17. The distribution stand is also designed so that it can be broken down into two halves, both of which can have either 2 or 3 outlets. This may be more useful where population concentrations are around 500 people. Extra fittings are provided in the kit for this purpose. However the two halves are not self-supporting and will require either a post or wall to which they should be fixed.

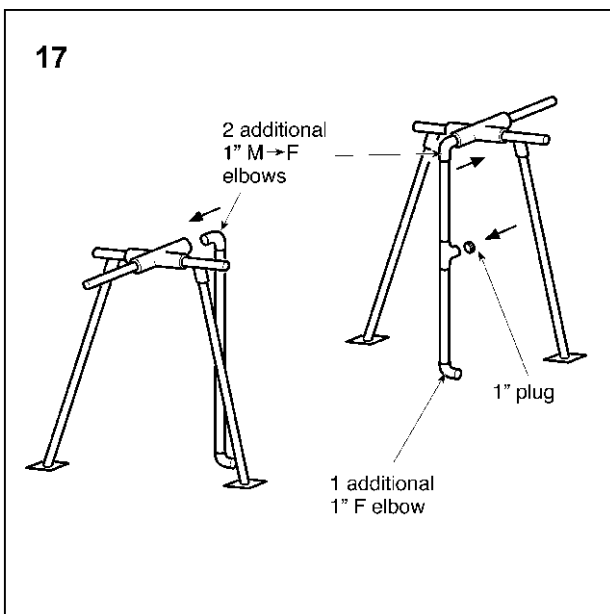

18. Remove the thread protection and screw the six water-saving valves on to the projecting pipes, using PTFE tape to make a watertight joint; make sure that the valves sit vertically, once tightened up. If only 4 valves are required, screw two plugs on to the ends of the pipe.

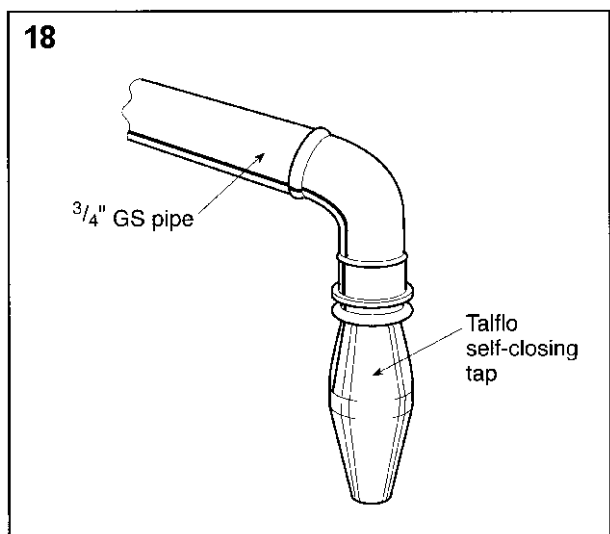

19. Connect the distribution stand to the main, using a short length of 32mm PE pipe, which in turn can be connected either to the 63mm pipe of the 90mm main. The coils of PE pipe should be unrolled, rather than pulled out. Connect the pipe, using the compression threaded couplings. Clean all threaded fittings and make joints, using PTFE tape. If pipes need to be extended, compression couplings may be used. Bury the pipeline in a shallow trench. If there is a shortage of compression fittings, then heat welding, or threading the outside of the pipe and using GS sockets, can be used as ways of jointing the pipe.

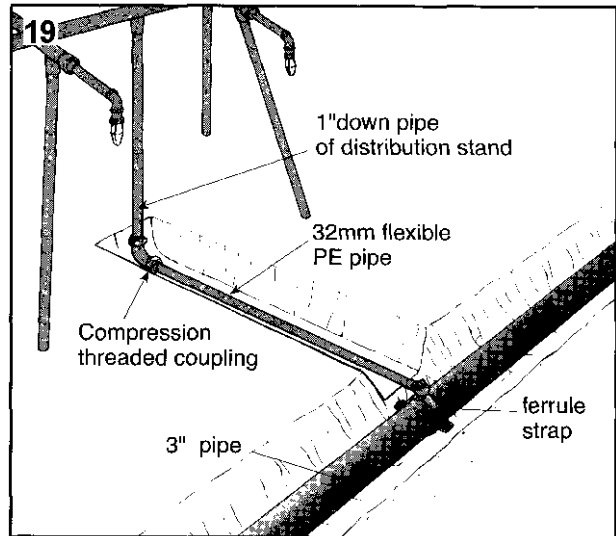

20. The distribution stand needs to be set high enough to allow sufficient clearance between the ground and the nozzle of the tape, to allow water containers to be positioned easily beneath the tap. Typically, a gap of 500mm between the tap nozzle and the ground is sufficient. Initially the distribution stand can be dug into the soil and a drainage channel can be dug to carry spilled water away from the area. At a later date, if the distribution stand is to be permanent, either cast the frame into a concrete foundation/apron, or bolt the feet to timber cross-members and spread a layer of stones under the stand. Remember to set the stand high enough to encourage drainage. It may also prove necessary in badly drained areas to dig small soakage pits, which could be filled with stones, to absorb excess water.

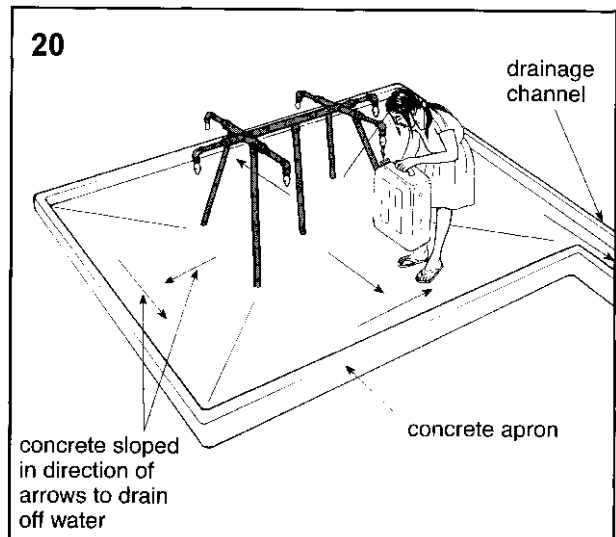

SECTION C - OPERATIONAL INFORMATION

Commissioning

Check that all screwed pipe joints are tight.

Flush out the pipes, to clear any material which may have collected during installation and which might cause blockage and contamination. This should be done first by use of the drain and then by disconnecting the pipes from the collection points.

Eliminate any air locks by manipulation of pipes and, if necessary, operation of vents and water saving valves.

Check that all 90mm fittings in the pipe are well fixed, as water pressure will easily blow push-fit joints apart, unless a thrust block is provided to resist this. Likewise, provide a removable thrust block at the capped drainage point, by putting a heavy rock against it.

Check for any leaks. These may be at loose couplings or at push-fit joints that are incorrectly fitted. Both of these are simply remedied. In the very unlikely event of a leak occurring in the wall of the pipe, this may be repaired by cutting out the leaking section of pipe and replacing it by a straight compression coupling.

When all pipes have been checked for leaks, backfilling of the trenches may be completed. Construct special protection where vehicles may pass over pipes.

Operational considerations

Very little maintenance is needed for this system; the only part possibly requiring attention are the strainer and the water-saving valves. The strainer will block up after a time if the incoming water is silty. Therefore periodic cleaning is necessary.

The watersaving valve is designed to be self-closing, is robust, and should give little trouble. The most likely problems are caused by grit lodging between the washer and its seating, and

the washer itself becoming worn. However, the plastic sleeve itself can also wear, either due to enlargement or to the top surface wearing, where the washer sits, both of which will eventually cause leakage. Thus it is suggested that the washers are replaced at least once per year and where required the plastic sleeve should be replaced too. Some spares for the valve are supplied in the DF3 box, but additional spares should be ordered for longer-term programmes.

It is possible that modifications may be required in the layout at a later date. This presents no problem, as all joints can be dismantled, although the push-fit joints can be difficult to separate. This is caused by the special lubricant drying out. Nevertheless, it is still possible to separate these joints. If branches are removed, the ferrule straps can be closed off by screwing the cutter down into the 90mm Ø pipe.

Where pipe is to be installed and used in conditions in which the temperature drops below freezing, some consideration needs to be given to prevent or minimise water freezing and to protect pipes from damage. PE pipe remains ductile in temperatures down to -60°C , though UPVC becomes quite brittle at temperatures of less than -10°C . Where it is not possible to insulate pipes, these should be drained at night or during other periods in which water is not flowing through them for significant periods of time. Where pipe has been buried in 400mm deep trenches, this will prevent water freezing at temperatures just below 0°C . If temperatures are likely to be lower, then either trial pits can be dug to determine the depth to which the frost penetrates or local advice sought as to suitable depth to bury pipes. However pipework above ground, especially smaller diameter pipes, needs to be insulated in other ways, such as with foam insulation or tapstands can be surrounded by soil contained in a box. In cold temperatures consideration also needs to be made of users and to the provision of shelter around the tapstand, as small children and elderly people in particular will suffer if queuing for long periods of time in the cold.

Storage and reuse of kits

All of these kits are designed for reuse and thus can be dismantled and packed away for further use as required. However, particularly with the DF3, DLR and DA kits, which have numerous

components and some consumable materials such as PTFE, repackaging of the kits will have to be conducted with care. All items should be checked back into boxes and ticked off against the original packing list and items replaced as required to make up a complete kit.

SECTION D – DETAILS OF KITS AND SUPPLIERS

Full list of kit contents

90mm Ø (OD) PVC Distribution Main Kit, 504m

Oxfam code DMU3

(approximate gross weight 800kg and volume 3.95m³).

Item	Qty	Description
1.	2	Bundles of 63 lengths of 4m x 90mm Ø 8 Bar pressure uPVC pipe to W.I.S.:43106, with integral EPDM socket one end, other spigotted end bevelled c/w rubber rings.
2.	2	0.5 litre tins of lubricant (1 tin sufficient for 80 joints)

90mm Ø (OD) UPVC/PE Distribution fittings kit

Oxfam code DF3

(approximate gross weight 120kg and volume 0.58m³).

This kit is for use with both DMU3 and DMP3.

Item	Qty	Description
1.	3	90mm Ø OD compression tee, FIP code JTZ or equivalent
2.	6	90mm Ø OD x 3" Ø BSP (M) coupler, FIP Code JMZ or equivalent
3.	2	90mm Ø OD compression elbow 90 ⁰ FIP Code JGZ or equivalent
4.	3	90mm Ø OD compression coupler, FIP Code JBZ or equivalent
5.	6	3" Ø BSP (M) hex nipple GS
6.	2	3" Ø BSP (F) cap GS
7.	3	3" Ø BSP (F) elbows GS
8.	3	3" Ø BSP (F) Tees GS
9.	1	3" Ø BSP (F) brass `Y' strainer c/w 2 spare coarse screens
10.	2	3" Ø BSP (F) brass gate valve
11.	4	3" Ø BSP (F) hose connector (malleable iron)
12.	6	3" Ø Hose clip, bolted type, (86-91 mm)
13.	4	32mm Ø OD UPVC compression coupler
14.	4	32mm Ø OD UPVC compression elbow 90 deg
15.	20	12m rolls PTFE jointing tape (12mm wide)
16.	2	Talflo taps (Oxfam Code DV)
17.	2	Seat support washer for Talflo tap
18.	2	Seat washer for Talflo tap
19.	2	'O' ring for Talflo tap
20.	2	Nut for Talflo tap
21.	1	Oxfam Water Distribution equipment Manual

63mm Ø (OD) Distribution Fittings for PE and UPVC pipe

Oxfam code DF2/1

(approximate gross weight 58kg and volume 0.17m³), comprising:

Item	Qty	Description
1.	8	90mm Ø OD UPVC compression coupler
2.	4	90mm to 63 mm UPVC reducing tee
3.	2	3" (M) to 2" (F) reducing bush GS
4.	4	3" Ø hose clip, bolted type (86-91mm)
5.	4	63mm Ø OD UPVC compression coupler
6.	4	63mm Ø OD UPVC compression tees
7.	8	63mm Ø to 32mm Ø OD UPVC compression reducer
8.	4	2" Ø BSPx 63mm Ø OD compression coupler
9.	1	Oxfam Water Distribution equipment Manual

32mm Ø (OD) PE Distribution pipe kit, 50m

Oxfam code DP

(approximate gross weight 15kg and volume 0.28m³), comprising:

Item	Qty	Description
1.	1	50m coils 32mm Ø OD blue PE pipe for potable water use, PE80 SDR 11 to BS 6572, 12.5 bar pressure rating, complete with end plugs.

63mm Ø (OD) PE distribution main/pipe, 50m

Oxfam code DPP2

(approximate gross weight 25kg volume 0.30m³) comprising:

Item	Qty	Description
1.	1	50m coils 63mm Ø OD blue PE pipe for potable water use, PE80 SDR 11 to BS 6572, 12.5 bar pressure rating, complete with end plugs.
2.	1	63mm Ø OD UPVC compression coupler

Distribution stand kit**Oxfam code DS**

(approximate gross weight 30kg and volume 0.04m³), comprising:

Item	Qty	Description
1.	1	Distribution Tapstand comprising of the following components preassembled either by welding or lock nut: GI 1" Ø twin elbow connected to 2 lengths of GI pipe 1" Ø pipes. 2 GI 1" Ø crosses, connected to 2 No lengths of 130mm GI 1" Ø with 4 x 1" Ø sockets welded on to take distribution stand legs.
2.	4	225mm long GI pipe 3/4" Ø, with 1"(F) to 3/4" (F) reducer.
3.	2	225mm long GI pipe 3/4" Ø, with 1"(M) to 3/4" (F) reducer.
4.	4	1" Øgalvanised steel frame legs.
5.	1	1" Øgalvanised down pipe, c/w with 1" galvanised elbow (F)
6.	4	M10 x 100mm long coach bolts and nuts.
7.	4	3/8" x 3" long coach screws.
8.	1	Pack containing 1 roll PTFE tape and 4 - M10 Nuts.
9.	4	1" ØBSP (M) x 32mm ØuPVC compression coupling
10.	6	3/4" ØBSP (F) Talbot Talflo valve, single seal.
11.	2	3/4" ØBSP (F) galvanised end cap.
12.	1	3" (88/92mm) x 1" gunmetal self tapping ferrule
13.	1	1/2" - 1" ferrule key
Additional pieces to make up extension and 2 No 2/3 outlet tapstands.		
14.	2	1" M - 1" F elbow
15.	1	1" M plug
16.	1	1" F elbow
17.	2	200mm extension piece 1" dia, threaded both ends c/w 1" socket

Distribution adaptation kit**Oxfam code DA**

(approximate gross weight 110kg and volume 0.03m³), comprising:

Item	Qty	Description
1	2	4" Ø hex nipple GS
2	2	4" Ø equal tee (F) GS
3	2	4" Ø (F) x 3" Ø (F) reducer GS
4	3	3" Ø equal tee (F) GS
5	3	3" Ø equal tee (F) GS
6	2	3" Ø (F) x 2.5" (F) Ø reducer GS
7	3	3" Ø (F) x 2" (F) Ø GS
8	2	3" Ø (F) x 1" (F) Ø reducer GS
9	1	2.5" Ø equal tee (F) GS

10	2	2.5" Ø hex nipple GS
11	1	2.5" Ø brass gate valve
12	4	2" Ø hex nipple GS
13	2	2" Ø hose connector (F), c/w washer clinch ring and hose clip
14	2	2" Ø equal tee (F) GS
15	1	2" Ø (F) x 1" Ø (F) reducer GS
16	1	2" Ø (F) x 1" Ø (F) reducer GS
17	2	1.5" Ø hex nipple GS
18	1	1.5" Ø brass gate valve
19	1	1.5" Ø (F) x 1" Ø (F) reducer HS
20	6	2" Ø (F) DN50, Guillemín quick-release hose coupling c/w washer and clinch ring
21	2	3" Ø (F) DN80, Guillemín quick-release hose coupling c/w washer and clinch ring
22	20	rolls of PTFE tape
23	5	Tubes of silicon-type sealant, suitable for air freight
24	1	Mastic gun for use with above tubes of sealant

Distribution layflat/rapid fittings kit**Oxfam code DLR**

(approximate gross weight 192kg and volume 1.05m³), comprising:

Item	Qty	Description
1.	1	100 metre coil, 75mm layflat pipe, pressure rating. Fitted with a 80mm aluminium coupling
2.	2	20 metre coil, 75mm layflat pipe, pressure rating. Fitted with a 80mm aluminium coupling
3.	5	5 metre coil 2" green flexible pipe (non 2 bar pressure rating, fitted a 50mm aluminium coupling
4.	4	80mm x 50mm Guillemín aluminium coupler.
5.	4	3" BSP (M) x 80mm Guillemín aluminium
6.	5	50mm Guillemín x 1 1/2" BSP (M) aluminium coupling.
7.	5	1 1/2" BSP (F) x 1" BSP (M) reducer.
8.	2	2" BSP (F) x 50mm Guillemín aluminium
9.	2	50mm Guillemín coupling ring key.
10.	2	80mm Guillemín coupling ring key.
11.	2	50mm Guillemín aluminium Tee.
12.	1	50mm Guillemín aluminium plug.
13.	5	Rolls of PTFE Tape.
14.	10	Gaskets for 50mm Guillemín fittings.
15.	10	Gaskets for 80mm Guillemín fittings.

The following kits are not stocked by Oxfam but can be ordered if required:

110mm Ø (OD) Distribution Fittings Kit for HEP₃O and uPVC pipe
Oxfam Code DFU4

Item	Qty	Description
1.	2	110mm Ø equal Tees with integral EPDM socket ends, c/w rubber rings
2.	4	110mm Ø x 90mm Ø reducer with integral EPDM socket end, c/w rubber ring
3.	2	110mm Ø elbows 90 with integral EPDM socket end, c/w rubber ring
4.	2	110mm Ø x 63mm Ø (F) gunmetal self-tapping ferrule strap
5.	1	½" - 1" ferrule key

160mm Ø (OD) Distribution Fittings Kit for HEP₃O and uPVC pipe
Oxfam Code DFU6

Item	Qty	Description
1.	2	160mm Ø equal Tees with integral EPDM socket ends, c/w rubber rings
2.	4	160m Ø x 90mm Ø reducer with integral EPDM socket end, c/w rubber ring
3.	2	160mm Ø x 110mm Ø reducer with integral EPDM socket end, c/w rubber ring
4.	2	160mm Ø elbows x 90mm Ø with integral EPDM socket end, c/w rubber ring
5.	2	160mm Ø x 63mm Ø (F) gunmetal self-tapping ferrule strap
6.	1	½" - 1" ferrule key

List of suppliers used by Oxfam (based in the United Kingdom)

The distribution main, code DMU3, is supplied by:

Uponor Ltd., PO Box HT 14, Leeds LS10
Tel (0)1532 701160, Fax (0)1532 719740

The distribution pipe, code DP and main/pipe DPP2, is supplied by:

Stewart and Lloyds Plastics, St Peters Road, Huntingdon, Cambridgeshire. PE18 7DJ
Tel (0)1480 52121, Fax (0)1480 458829

90mm Ø (OD) PE Distribution Main Kit, 500m in coils

Oxfam Code DMP3

Item	Qty	Description
1	10	50m coils 90mm Ø OD blue PE pipe PE80 SDR17.6 (rated 7.5 bar), complete with end plugs.
2	10	90mm Ø OD compression joint coupler.

110mm Ø (OD) Hep₃O Distribution Main Kit, 500m

Oxfam Code DMU4

Item	Qty	Description
1.	3	Bundles of 42 lengths of 4m x 110mm Ø blue HEP ₃ O 10 bar pressure pipe with integral EPDM socket c/w rubber rings.
2.	4	0.5 litre tins of lubricant (1 tin sufficient for 45 joints)

160mm Ø (OD) Hep₃O Distribution Main Kit, 500m

Oxfam Code DMU6

Item	Qty	Description
1.	5	Bundles of 26 lengths of 4m x 160mm Ø blue HEP ₃ O 8 bar pressure pipe with integral EPDM socket c/w rubber rings.
2.	6	0.5 litre tins of lubricant (1 tin sufficient for 30 joints)

Re-ordering

If it is necessary to re-order individual items, please describe them as specified in the contents list and quote the name and code number of the kit in which the item occurs.

The distribution frames and pipefittings, codes DS, DLR, DF2 and DF3, are supplied by:

Even Products Ltd, Oxtalls Farm, Evesham, Worcs, WR11 4TS

Tel (01386) 41212, Fax (01386) 765404

The distribution frames and pipefittings, codes DS, DF2 and DF3, are supplied by:

Akro Valve Co, Unit 2, Chaucer Industrial Estate, Dittons Road, Polegate, East Sussex

Tel: (01323) 485272, Fax: (01323) 485273

The Site Tool kit, and Ladder, codes OS and OT, are supplied by:

Kennedy Group Ltd, Wigston Works, Victoria Street, Wigston, Leicester, LE8 1AJ

Tel (0116) 2888777, Fax (0116) 2812393

Final reminders and recommendations

- Store UPVC pipes and fittings carefully away from direct sunlight.
- Carefully plan your pipe layout before starting work.
- Try to ensure that pipes are laid to a gradient to assist water flow and to avoid air locking. If air locking is unavoidable, venting facilities must be installed.
- Check that all pipes are clear of obstruction before installing.
- Protect all open-ended pipelines with paper or cloth plugs while pipes are being laid.
- Wherever possible, bury all pipelines to give adequate protection.
- Ensure that water-collection areas are well drained and kept clean.

References

1. Gravity Flow Water Systems, Jordan. IT Publications 1984
2. Engineering in Emergencies, Davis and Lambert. RedR/IT 1995
3. Out in the Cold, Buttle and Smith. WEDC 1998

Acknowledgements

The original development of the Water equipment packages was made possible with the generosity and professional skill of the University of Surrey and the Public Health Engineering section of Imperial College, London. Since then, active development and evolution of the water kits has continued, managed by the Oxfam GB Public Health Engineering Team, based on feedback from engineers working on response programmes and with continued input from suppliers, and others.

Richard Luff

JANUARY 2000

Oxfam is a partnership of people committed to relieving poverty, distress and suffering in any part of the world. We believe in the essential dignity of people and in their capacity to overcome the problems they face, whether they stem from natural, social, political or economic conditions.

This equipment is part of several packages devised by the Oxfam Public Health Engineering Team to help provide reliable water, sanitation and shelter facilities in emergency situations.

Oxfam (GB)
274 Banbury Road, Oxford OX2 7DZ, UK
Tel: (01865) 311311 Fax: (01865) 312600