

OXFAM PUBLIC HEALTH ENGINEERING

**GUIDELINES FOR EXCRETA
DISPOSAL IN EMERGENCIES**

An Oxfam Technical Manual



GUIDLELINES FOR EXCRETA DISPOSAL IN EMERGENCIES

Contents

	Page No
1.0 INTRODUCTION	1
2.0 DESIGN OF A SANITATION PROGRAMME	1
2.1 Initial rapid assessment	1
2.2 Tools for data collection	2
2.3 Planning	2
2.4 Co-ordination and integration	5
2.5 1 st Phase acute emergency	5
2.6 2 nd Phase stabilised emergency	5
3.0 PROGRAMME FORMULATION	5
3.1 Design specifications	6
3.2 Children's and infant's excreta	6
4.0 1ST PHASE TECHNICAL OPTIONS	7
4.1 Defecation fields and shallow trench defecation fields	7
4.2 Communal latrines	9
4.3 Designs for communal latrines	13
5.0 FAMILY LATRINES	15
6.0 LATRINE OPERATION AND MAINTENANCE	
6.1 Anal Cleansing material	17
6.2 Cleaning and maintenance	17
6.3 Fly Reduction	18
6.4 Sanitation Corridors	18
6.5 Latrine desludging	18
7.0 LATRINES IN DIFFICULT ENVIRONMENTS OR SETTINGS	19
7.1 High water tables	19
7.2 Rocky areas	20
7.3 Transit camps	21
7.4 Feeding centres	21
7.5 Urban environments	21
7.6 Borehole latrines	21
8.0 MONITORING AND EVALUATION	22
9.0 QUANTITIES AND COSTS OF SUPPLIES NEEDED FOR LATRINE PROGRAMME	22
Further reading	23
Appendix 1 Estimates for labour and materials for latrines construction	
Appendix 2 Slab Designs	
Appendix 3 Designs for hand washing	

By Andy Bastable, Technical Adviser, Oxfam, with contributions from Suzanne Ferron and some diagrams by Enamul Hoque. June 2000.

1.0 INTRODUCTION

The importance of good sanitation practice, especially excreta disposal can not be overestimated. Diseases transmitted via the faeco-oral route (e.g. diarrhoea, shigella, cholera and typhoid) can account for up to 50% of all deaths in an emergency. Studies (Esrey 1986, 1991) have shown that whilst improvements in water quality alone can produce limited reductions in childhood diarrhoea by 15- 20%, the greatest reduction was attributable to safer excreta disposal (36%) and hand washing, food protection and improvements in domestic hygiene (33%). For this reason Oxfam's Humanitarian Department has made it a strategic priority to place greater emphasis on sanitation.

The purpose of these guidelines is to give technical managers of excreta disposal programmes practical assistance in planning and implementing programmes. The guidelines focus on technical solutions for excreta disposal and **must** be read in conjunction with Oxfam Public Health Promotion Guidelines as no sanitation programme will succeed unless it is initiated and supported throughout by a community mobilisation/public health awareness campaign. The construction programme and the community mobilisation/public health promotion programme should be seen and planned as one programme. The guidelines are also to make people aware of what relevant kits have been developed by Oxfam's Public Health Engineering Team and how they can be used for a fast and effective response.

2.0 DESIGN OF AN EXCRETA DISPOSAL PROGRAMME

2.1 Initial rapid assessment

In an emergency, the aim is to start the safe excreta disposal programme as soon as possible. Firstly, however, baseline data must be collected to identify the best technical solutions, to ensure that the beneficiaries will use them and to provide some of the data necessary for assessing impact.

The initial assessment should include the following questions;

1. What is the estimated population and what is the population density?
2. What is the crude mortality rate (number of deaths per 10,000 people per day) and what are the main causes of mortality and morbidity?
3. What are the current beliefs and traditions concerning excreta disposal especially regarding women and children's excreta? (do men and women or all family members share latrines, can women be seen walking to a latrine, do children use potties, is children's excreta thought to be safe?)
4. What material/water is used for anal cleansing? Is it available?
5. Is soap available?
6. Are there any existing facilities? If so are they used, are they sufficient and are they operating successfully? Can they be extended or adapted? Do all groups have equal access to these facilities?
7. Are the current defecation practices a threat to health? If so, how?
8. What is the current level of awareness of public health risks?
9. Are there any public health promotion activities taking place? Who is involved in these activities? (community health workers, voluntary groups, home visitors).
10. What health promotion media are available/accessible to the affected population?
11. Are men, women and children prepared to use defecation fields, communal latrines or family latrines? Consult with the disabled and elderly also.
12. Is there sufficient space for defecation fields, pit latrines etc?
13. What is the topography and drainage patterns of the area?
14. What is the depth and permeability of the soil, and can it be dug easily by hand?
15. What is the level of the groundwater table?
16. What local materials are available for constructing latrines?
17. Are there any people familiar with the construction of latrines?
18. How do women deal with menstruation? Are there materials or facilities they need for this?
19. When does the seasonal rainfall occur?
20. Whose role is it normally to construct, pay for, maintain and clean a latrine (men, women or both)?
21. **NB See the Oxfam Public Health Assessment Tool/checklists for further details**

2.2 Tools For Data Collection

Interviews with key informants such as leaders, teachers, nurses, traditional birth attendants, people from the Ministry of Health and Sanitation etc will provide useful, initial data. Some countries also have a ministry specifically concerned with women's affairs and it is useful to discuss any gender issues relevant to sanitation with them. However to obtain more in depth information about practices and beliefs it may also be useful to organise a community mapping session with separate male and female groups. Community members will be able to give you important information about where there are problems with excreta disposal, what sort of toilets most people have, where people dispose of children's faeces and what possible solutions people would like to see.

HOW TO CARRY OUT A MAPPING EXERCISE

HOW TO CONDUCT A MAPPING EXERCISE

Mapping is a useful exercise which can be used to gain an overview of the situation and to identify excreta disposal problems which are causing a risk to people's health. A mapping exercise should also allow people themselves to appreciate possible risks and it can often be a catalyst for community planned action. It can be initiated simply by approaching a small group of people or by organising groups of people in advance. It is useful to conduct separate mapping exercises with women and men to ascertain their different views.

- Have a clear idea in your mind of the possible things that might be identified on a map such as church, market place, schools, areas of open defaecation, houses or shelters without latrines, areas of fly breeding etc.
- Identify possible resources that might be used for the map such as stones, leaves etc. but allow people to make their suggestions as you go along.
- Explain who you are and that you would like their help in conducting the exercise.
- Explain what you hope to find out and how the participants might go about making a map.
- Allow plenty of time for discussion of the idea of making a map - many people may be sceptical that they cannot do this because they have never been to school.
- If necessary begin the process yourself with a central landmark using a stick to draw on the ground. Try to "hand over the stick" as much as possible to other participants.
- Listen carefully to what people say and allow free discussion and debate amongst participants.
- Keep a record of who took part and when and where.
- When the map is finished, offer to transcribe it or get one of the participants to transcribe it onto paper. Ask the participants to decide where they would like the map to be kept, or who will keep it.

It might also be useful to compile quantifiable data from the mapping exercise. A table showing the quantities of each thing that has been drawn on the map (i.e. numbers of latrines in different locations.) can then provide a baseline for subsequent quantifiable evaluation or for the triangulation of results from questionnaire surveys. This can also be displayed with the map for those who can read.

2.3 Planning

Planning frameworks such as the logical framework are increasingly required by donors and provide a useful tool to ensure that objectives are well defined. Their use can also encourage more effective monitoring and evaluation and ensures a more rigorous and accountable approach to emergency work. In a rapidly changing environment, it is accepted that such a framework will be less than perfect and may need to change frequently to accommodate the situation on the ground.

LOGICAL FRAMEWORK ANALYSIS: A PLANNING TOOL FOR AN EXCRETA DISPOSAL PROJECT

This logical framework assumes a population of 50,000 newly displaced people arriving in a camp setting and considers the excreta disposal requirements only. In reality close co-ordination and collaboration would also be needed with those involved in the provision of water and a joint logical framework might be more appropriate. Sphere Minimum Standards have been used to promote familiarity but Output Objectives should endeavour to be more specific if presenting this framework to donors.

NARRATIVE SUMMARY	MEASURABLE INDICATORS	MEANS OF VERIFICATION	IMPORTANT ASSUMPTIONS
AIM/GOAL To contribute to improving the health of the at risk population	mortality and morbidity rates from all causes	health centre records, mortality records from	Assumes that stability is maintained and that further migration, does not take place, assumes easy access to population
PURPOSE 1 To reduce the incidence of diseases associated with inadequate excreta disposal for 50,000 displaced persons for six months	mortality and morbidity rates from diarrhoeal diseases	health centre records, volunteer and public health team 's monitoring forms	Assumes that the major cause or risk of mortality and morbidity is associated with excreta related disease and that beneficiaries see the project as a priority need for them
PURPOSE 2 To begin the process of capacity building within the displaced community to ensure heightened capacity to respond to future emergencies	Ability to mobilise community members and define and carry out relevant actions, increase in knowledge about prevention, organisation of sanitation committees	Project records, community discussions	Assumes that some community structures remain and can be reactivated
OUTPUT 1 To ensure adequate excreta disposal and to ensure that people have sufficient numbers of toilets, sufficiently close to their dwellings to allow them rapid, safe and comfortable access at all times of the day and night (Sphere Excreta Disposal standard 1)	Ratio of latrine coverage 1/20 Public Toilets available in public places People feel the toilets are safe and private	Project records, observation, focus group discussions	Assumes government support for project continues and land is available for the construction of latrines
OUTPUT 2 All sections of the community are aware of what they can do to prevent diarrhoeal diseases and are mobilised to take action to control them (based on Sphere Hygiene Promotion Standard 1)	People use the toilets available and children's faeces are disposed of immediately and hygienically, household toilets are cleaned and maintained, people wash their hands with soap or ash after defaecation and handling children's stools	Observation of camp, latrine monitoring forms, excreta maps, focus group discussions, pocket charts,	Assumes project meets a felt need of the community
OUTPUT 3 Communities are involved in all programme activities and take key decisions in project design and implementation	Representation from all sections of community in detailed assessment, community defined objectives for action	project records, focus group discussions and interviews with key informants	Assumes that defined priorities of the various groups are considered important by the team and facilitated by the management structures
ACTIVITY 1 Recruit and train 5 mobile sanitation teams each with a supervisor to organise excreta clean up within two days of arrival	Numbers of staff identified and training completed	Project records, training evaluation	Assumes people will continue to be available for this job

ACTIVITY 2 Recruit and orientate five Public Health Promoters to collect baseline data and information about community latrine design preferences	number of focus groups and research sessions held with different groups, quality and quantity of data gathered	Project records and reports	Assumes continued willingness of Ministry of Health to second counterparts
ACTIVITY 3 Establish communal latrine system within five days including handwashing facilities and trained latrine attendants	Number of trenches constructed with handwashing facilities and attendants	Project records, observation	Assumes that people can be encouraged to use the trench systems temporarily
ACTIVITY 4 Distribute potties to each family with children between one and five (1 potty for every two children) and nappies for children under one (four nappies per child)	Number of potties distributed and potty/children under five ratio	Household assessment forms, project records	Assumes that people will use facilities provided for use intended
ACTIVITY 5 Hold regular community meetings with camp leaders and representatives (ensuring representation from women, elderly and disabled) to discuss family latrine programme and operation and maintenance	Number of meetings held and number and profile of people attending	Project records, minutes of meetings	Assumes that people will continue to feel that excreta disposal is important
ACTIVITY 6 Establish family pit latrines for 10,000 families within 2 months ensuring privacy and safety for women	Number of family latrines constructed, women feel they are safe and private	project records, latrine monitoring forms	Assumes willingness of community to contribute to digging of pits
ACTIVITY 7 Train 100 volunteers selected from the camp within one month (to promote the use and maintenance of excreta disposal systems)	Number of volunteers selected and trained, quality of training, subsequent activities	Project records, training evaluations, volunteer work plans	Assumes willingness of community to volunteer for these activities
ACTIVITY 8 Design posters and training aids to provide key information about prevention and simple treatment of diarrhoea	Number and quality of materials designed and used	project records, feedback from community members	Assumes availability of printing facilities
ACTIVITY 9 Recruit and train ten teachers from the camp to promote the use of safe excreta disposal and the prevention of diarrhoea	Number of teacher's trained	project records, training evaluation	Assumes willingness of Ministry of Education and teachers to take part in activities
ACTIVITY 10 Ensure close liaison with Ministry of Health and Sanitation and other agencies involved in water and sanitation	Number of meetings attended, agreements signed	project records	Assumes adequate co-ordination maintained

2.4 Co-ordination And Integration

In most emergency situations it will be necessary to ensure not only safe excreta disposal but also adequate amounts of clean water, effective solid waste disposal and control of major vectors to limit the spread of disease and the programme should therefore usually be planned as an integrated whole. It is important to ensure that an excreta disposal programme optimises the potential for combining these interventions. The programme will need to ensure that there is:

- **Adequate water for anal cleansing and handwashing and adequate drainage**
- **Tight fitting covers for any water containers used for handwashing etc.**
- **Covers for latrines to limit fly breeding**
- **Fly traps available where necessary**

Co-ordination will also be necessary with those involved in selecting and planning the site and it is important that discussions are held with all the relevant co-ordinating bodies.

2.5 1st Phase acute emergency

During this phase the main aim is to protect the health and life of the affected population as quickly as possible until more longer term solutions can be found. In this stage mortality rates are often high (over 1 per 10,000 per day) and the risk of major epidemics is high. In a large scale population displacement (>20,000) the first phase may continue for several weeks. The objective of the excreta disposal programme is to achieve or surpass the Sphere minimum standards. It is recognised however, that it may not be possible to achieve these standards in the 1st phase of a large scale emergency. The minimum standards should be met however, during the 2nd phase or subsequent 6 months.

2.6 2nd Phase Stabilised Emergency

During this phase community structures may start to reassemble and morbidity and mortality rates should start to fall. However the risk of epidemics may still be high. More long lasting excreta disposal systems should now be initiated or completed. The definition of the phases of an emergency is not fixed and many situations do not follow a linear progression. Some programmes may commence in the 2nd phase or become more acute because the security situation deteriorates or the outbreak of an epidemic.

3.0 PROGRAMME FORMULATION

Decide on the priority interventions and how these will be organised. Several activities may start at the same time or may need to continue into different phases of the programme:

- It may be necessary to immediately start a clean up campaign if there has been open defecation which is causing an obvious health hazard. The population can be mobilised, using rapidly identified and recruited public health promoters (community mobilisers) and given the resources (lime, spades, wheelbarrows, sacks) to mobilise people to do the clean up. It may be necessary to pay workers to do this.
- In the first phase the public health promoters would also need to initiate an information exchange. The population needs to be informed about where they can and can not defecate and why indiscriminate defecation is a problem in areas of high population density. They may also need to be reminded of the importance of handwashing especially following defaecation and handling children's stools
- As part of the sanitation team, the Public Health Promoters also need to obtain information about which system of excreta disposal is most appropriate and where facilities should be sited.
- If appropriate, start shallow trench defaecation enclosures immediately, while beginning the planning for communal or family latrine construction.
- Consider whether there need to be special facilities for children through discussions with the Public Health Promoters
- dig a number of trial pits around the camp to determine: soil stability and permeability, depth to bedrock and depth to water table. This will influence the decision to build lined or unlined pits, raised latrines or to go for more technical solutions such as septic tanks, small sewage systems or small treatment systems.
- If appropriate, start building communal latrines and ensure that latrine attendants have been selected and trained

- It may be possible to initiate the family latrine programme at the same time as providing a minimum of communal latrines if families are willing to dig latrines themselves. They may want to borrow tools for digging. This aspect of the programme could be managed by the public health promoters.
- Is it possible to upgrade any existing sanitation facilities?

3.1 Design Specifications

COVERAGE:

- Sphere Standard: Maximum of 20 people per latrine. (In initial phase aim for 50 p/p/latrine) Trench latrines maximum of 100 people per 3.5m length of trench at 1m deep and 300mm wide. **Separate toilets may need to be provided for men and women – distance to be determined following consultation with women. Ensure disabled toilets and facilities for children**

POSITION:

- Toilets should be no more than 50m from dwellings Pit latrines should be a minimum of 6m from dwellings. Latrines should be at least 30m from any ground water sources. Latrines should be available in public places such as markets, health centres & food/non-food distribution points.

PIT DEPTH

- The bottom of the latrine should be at least 1.5m above the water table. In fine unsaturated soils and unconsolidated strata within 1.5m virtually all bacteria, viruses and other faecal organisms are removed. This distance will increase in large grained soils, gravels or fissured rock.

ACCUMULATION RATES (approx.)

- **Solids:** 0.5 Litres/person/day in emergencies (0.04 - 0.15m³/person/year in stable situations)
Liquid: 0.8 Litres/person/day where water is not used for anal cleansing (approx.) If water is used for anal cleansing the design figure is 1.3 l/p/d. In the initial phase, before wash areas are constructed, people may wash in latrines in which case the figure could be 8 – 10 l/p/d

OTHER:

- **Ensure locks for doors. Security lighting may also be necessary. Provide handwashing facilities and if necessary water or other materials for anal cleansing. Special rails may also be necessary to assist the disabled and elderly.**

3.2 Children's And Infant's Excreta

Children under five often make up a significant proportion of the population in many poorer countries – up to 20% in some instances. It is therefore important that ways are also found to dispose of their excreta safely. This issue must be discussed with mothers especially to identify whether nappies, potties or specially designed latrines will be necessary.

In the camps in Freetown, Sierra Leone, potties were distributed to all families with children under five – one potty between two children.

In Albania and Macedonia disposable nappies were provided in some of the hygiene kits distributed by other agencies. Whilst they were convenient they were also difficult to dispose of and were often found to be creating an additional Public Health risk as they were often found littered around the camp. Washable nappies would have been preferable and mothers claimed they preferred them as it was what they were used to.

In Rwanda special children's latrines were provided and used by children of two years old and above. Th latrines had a smaller squat hole and were open so that children did not get frightened using them .

4.0 1ST PHASE TECHNICAL OPTIONS

For excreta disposal the 1st phase technical options are normally ;

- Defecation fields and shallow trench defecation fields
- Communal latrines

Exceptions to this are:

1. **if the area is flooded**
2. **if there is a high water table**
3. **in urban areas where land may not be available**

Privacy and security are vital if people are going to use latrines. In Albania women were forced to go to the toilets in pairs because the toilets had no locks on the doors. Women's safety may be compromised if toilets are too far from their shelter and they may not use them if they think they are not safe. Night lighting may need to be provided to avoid this problem. . Sexual harassment often increases in the confines of a camp and the location of sanitation facilities should ensure that the risks to women are minimised.

Areas of hard bedrock may also cause problems. Options for these situations are dealt with in Section 7.0

4.1 Defecation fields and shallow trench defecation fields

A defecation field is simply a fenced off area for defaecation which is managed in a controlled way. In really extreme situations it may be necessary to make open defecation fields by just marking off areas with tape. However, this is rarely necessary and the lack of privacy may make them ineffective. It is nearly always possible to at least surround an area in plastic sheeting or fabric and dig a few shallow trenches. **Wherever possible avoid defecation fields and install trench latrines as a first option.**

Divide the field into strips 1.5m wide with access paths. Use strips furthest from the entrance first. When a section of trench has its bottom layer fully covered with excreta it is filled in. Only short lengths of trench should be opened for use at any one time to encourage the full utilization of the trench in a short time. It may be appropriate to have a number of trenches open at the same time. A rule of thumb is to allow 0.25 m² of land per person per day. This means 250 m² per 10,000 people per day, or nearly 2 hectares per week. Men and women's areas should always be separated. Intensive defecation fields are dealt with under latrines in hard rock areas, section 7.21 .

An easy way to upgrade simple trench latrines is to put plastic squat plates over the trenches then make cubicles out of plastic sheeting. The Oxfam LST/1 kit, designed to be used with the Oxfam Plastic Slab, contains all the materials necessary to construct simple cubicles in blocks of 4.

Diagram of shallow trench defecation field

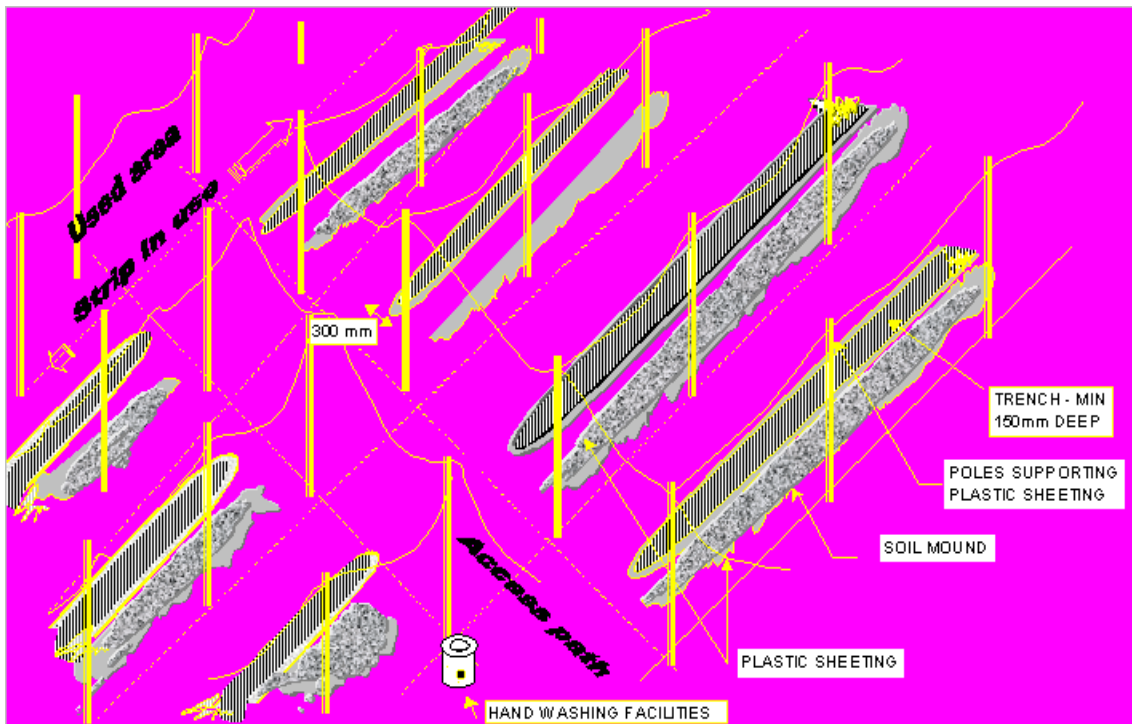

Whilst simple in concept and construction, the operation of defaecation fields requires careful control to ensure they are used as intended to keep health risks to a minimum. Attendants will need to be recruited and provided with training to encourage effective use of the trenches and to encourage handwashing following use. A network of Public Health Promoters will also be needed to sensitise the population on the importance of using the fields. It is rare that these fields will be used by everyone as privacy will be a major issue and therefore they should only be instigated if the risks are significant and if there is no other rapidly implemented alternative.

4.11 Location

The location of the field must be discussed with the population. The field should be at least 30 metres from dwellings but located as centrally as possible to the people who are going to use them (within 100 metres of shelters if possible). They should be on land sloping away from the camp and surface water sources, the field should be surrounded by a drain so that surface water cannot enter and to prevent any runoff from the field contaminating other areas. Whilst an open field is easier to manage, the affected population may prefer a site with trees, and bushes to provide privacy. Consideration should be given to the direction of prevailing winds, to reduce nuisance caused by odour. Areas subject to flooding or containing running water should be avoided. The soil should be easy to dig so that faeces can be buried. The defecation field should be provided with adequate surface drains to prevent surface water running across them from above and to collect and contain any seepage of liquid effluent.

4.12 Operation

Users need to be encouraged to use the strips furthest away from the entrance and to cover their own excreta with earth and to wash their hands afterwards. To ensure the sanitary use of the field

- **Provide full time supervision in the form of paid attendants**
- **Provide anal cleaning materials and methods for its safe disposal.**
- **Provide hand-washing facilities.**

Each field should have at least two persons present at all times to guide the individual to the right area and ensure that other areas of the field are not used. Marking tape and paint are in the Oxfam Defecation Field Kit (Code LF/1) to facilitate marking out of the zones and for making signs to direct people to the correct area for defecation and for posting other simple messages on any suitable board or surface. Also, in the LF/1 kit is a 200l plastic barrel which can be situated at the entrance of the area. Soap or ash will also need to be provided for effective handwashing. If neither is available, the barrel can be filled with a 0.05% chlorine solution. A 0.05% solution is made by adding half a table spoon (7.5g) of HTH (70%) chlorine granules, or 15g of bleach,

to 10l of water. It may be necessary to provide extra handwashing facilities depending on the numbers of people using the field. All excreta should be covered with soil as soon as possible to prevent the breeding of flies and reduce odours. If the users do not cover their faeces then the attendants should.

Where water is used for anal cleansing, a container of water should be supplied at the entrance to the field, together with small pots for individual use. This can be managed by the attendants along with the handwashing facilities. Where solids are used, the appropriate material may also need to be provided along with receptacles to collect soiled material. These materials should then be buried or burned and not deposited where they will create a health hazard.

4.2 Communal latrines

The success of any latrine programme will again depend on how much the affected population, especially women, are involved and how good the liaison is with the public health promoters, health workers, water engineers, and camp planners. It is not enough to simply build latrines: they must also be used and kept clean.

In the first phase of an emergency, if there are no existing latrines, a period of rapid latrine construction needs to be prepared for. In this preparation phase there should be as much co-ordination as possible with the affected population concerning the siting and type of latrines. Site maps should be drawn up to aid the equal distribution of communal latrines and to plan where latrine corridors can be put. A map can be drawn up with community members to involve them in this process of siting the latrines. If a community map is used it is very important to conduct this exercise with men and women and also with a technical advisor present to ensure that a consensus is reached on this important point.

It may not always be necessary to construct communal latrines as the population may be rapidly mobilised to dig their own family latrines which are always preferable if conditions allow.

Oxfam has a number of kits for the rapid construction of latrines. In some situations it can take some time to locally source all the materials that are needed to construct the slab and the superstructure. Initially, to get some latrines up and working as fast as possible plastic squatting slabs can be used, Oxfam code LOP/1 is a self-supporting plastic squat slab 1m x 1.1m. The LST/1 kit is a superstructure kit, consisting of poles which fit into holes in the plastic slabs and pre-cut strips of plastic sheeting to make a block of 4 latrines. Rolls of plastic sheeting, Code SPE, can also be used to make the superstructure with locally sourced supporting members. The Latrine digging kit, Code LD/2 is also extremely useful to order to save time initially sourcing local spades, shovels and picks

Due to management and maintenance problems, associated with communal services, communal latrines are normally seen as only a short term measure, before family latrines can be built or only for public places such as near markets, food and health centres. It may be necessary to pay workers (per latrine completed) in the initial phase for construction of communal latrines. However it is preferable, in order to promote ownership, care and maintenance, if community members can be motivated to build them. If community members are to build their own toilets then it may be necessary to provide help to those who may have no one available to do this such as female headed households, disabled families and the elderly. If wooden slabs are being used it is recommended to put a thin covering of cement, approximately 25mm thick, on top to facilitate cleaning.

4.21 Trench latrines

The diagram below shows a first phase trench latrine. After the trench has been dug the quickest option is to put plastic slabs straight over the trench. The Oxfam plastic slabs are 1m by 1.1m and are self-supporting, if these are being used then the trench needs to be 90cm wide at the top so the slab can rest on a firm support or ground 10cm on each side. If plastic Slabs are not available then wooden planks can be secured across the trench until proper wooden or concrete slab can be made, i.e. try and cover the pit with planks leaving out every 3rd or 4th plank which is where people defecate. All designs must be previously discussed with the community and should take into account the safety of women and children and elderly or disabled people.

First phase trench latrine

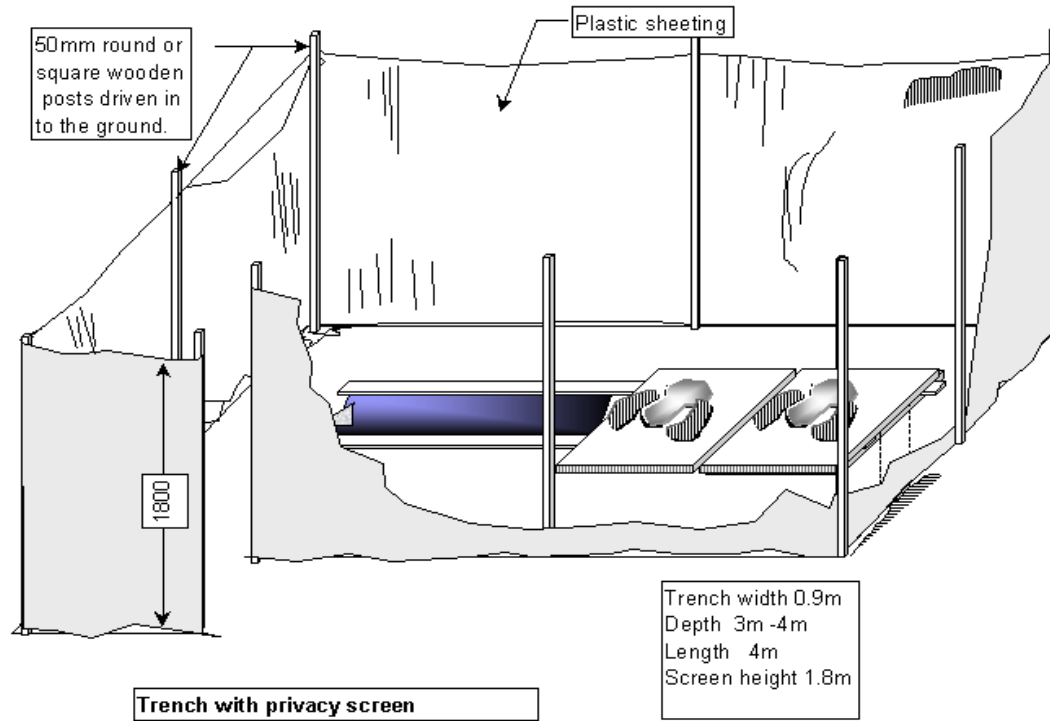
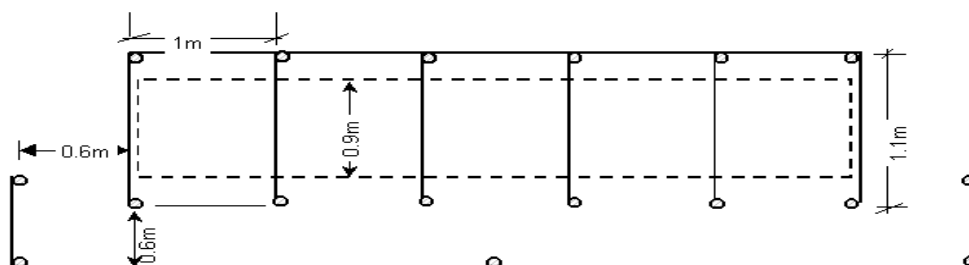
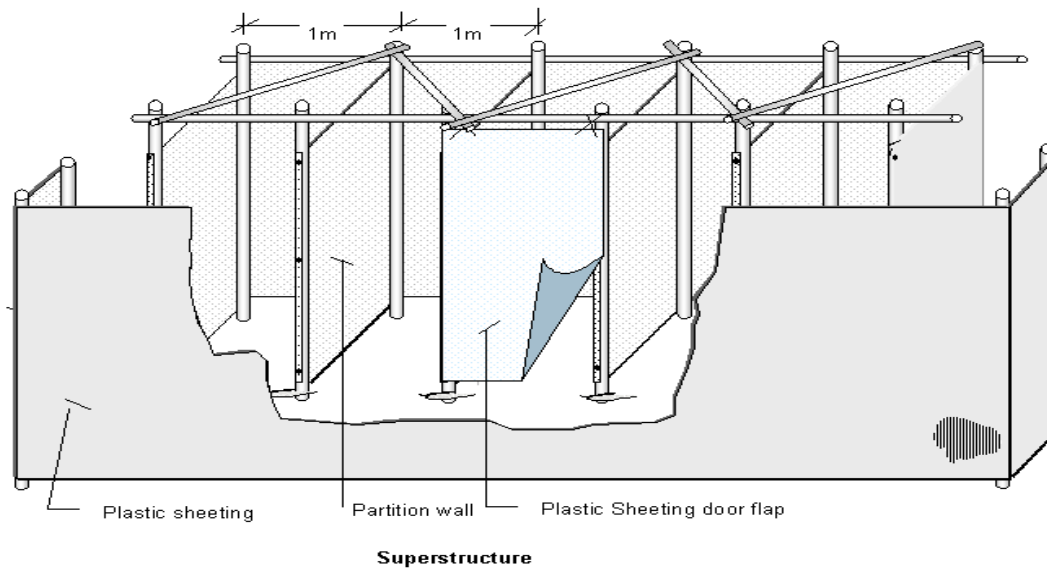

Diagram of simple latrine superstructure



4.22 Trench Excavation and lining

Before the costings for a latrine programme are completed a number of trial pits need to be dug to determine the pit depth and whether it is necessary to line the pits. Soil stability, depth to bedrock and the water table can therefore be established and the infiltration rate of the soil can be measured by filling the hole with water and recording the rate it decreases. Where possible avoid digging pits in sandy soils as they will have to be lined, which is expensive, silty or clayey soil is preferable. If the soil is very clayey it may not allow any percolation from the pit and some clay soils appear stable when dry but when saturated are liable to collapse. If the pit is being dug manually then it is recommended to have sloping side walls (5 deg.) rather than vertical walls, this is difficult to do with a mechanical digger. The most unstable area of the pit is normally the top 0.5m, normally it is good practice to line the very top of the pits to prevent the top giving way. Drainage trenches and earth banks sloping away from the latrine pit are very important to prevent surface runoff entering the pit which is the major cause of destabilizing of the top section. When making pits for single or double latrines circular pits are more stable.

Lining materials;

Wood	Time-consuming and difficult to position cross struts to provide a proper retaining wall. Prone to rotting even when treated.
Bamboo	Rots faster than wood, less strong but maybe in more plentiful supply in some parts.
Blocks/ Bricks/	Can be built honeycomb style to allow good percolation if the soil is not too loose.
Stone	Disadvantage of honeycomb is that small rodents can enter the pit.
Concrete rings	The liquid effluent cannot easily escape unless a the ring is made with drainage holes.
Ferrocement	May not hold back a big slump
Barrels	Not possible for the liquid effluent to escape, splash back problems
Metal sheets	Very little infiltration can take place – needs bracing
Corrugated Iron	“ “
Tyres	Requires a high quantity of old tyres

Generally, if lining then thought should be put into making the pit emptyable, this could make lining more cost effective. See section on desludging.

Diagram of concrete rings with ferrocement slab and bamboo matting lining

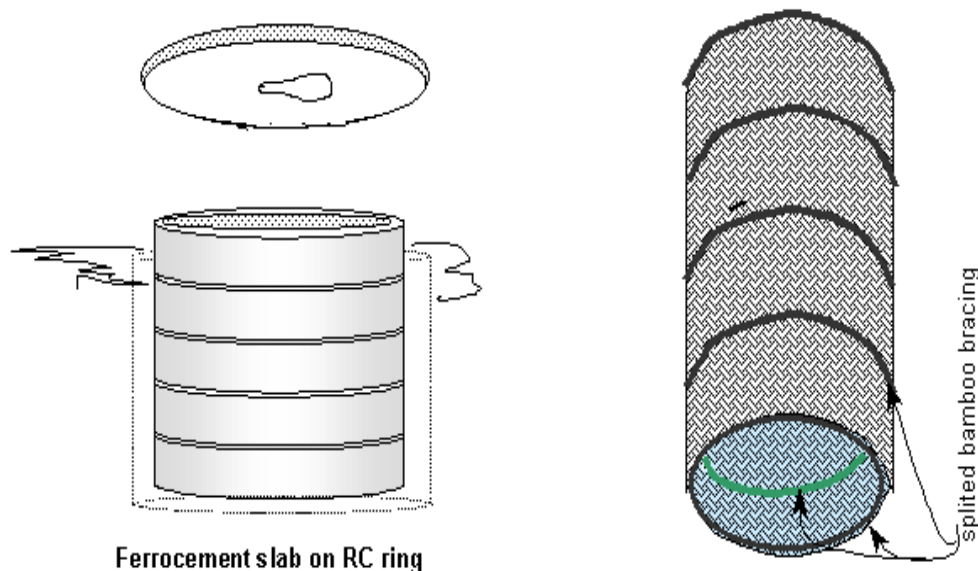

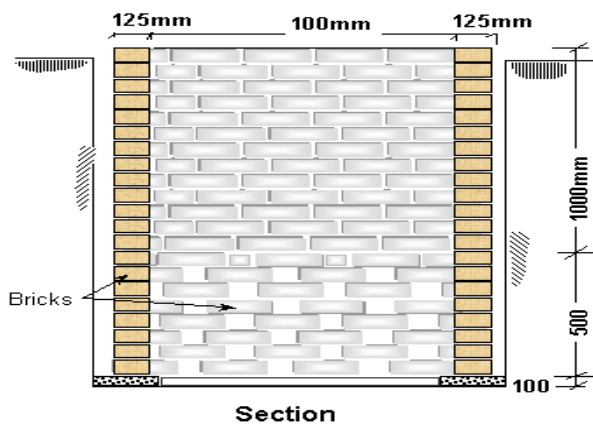
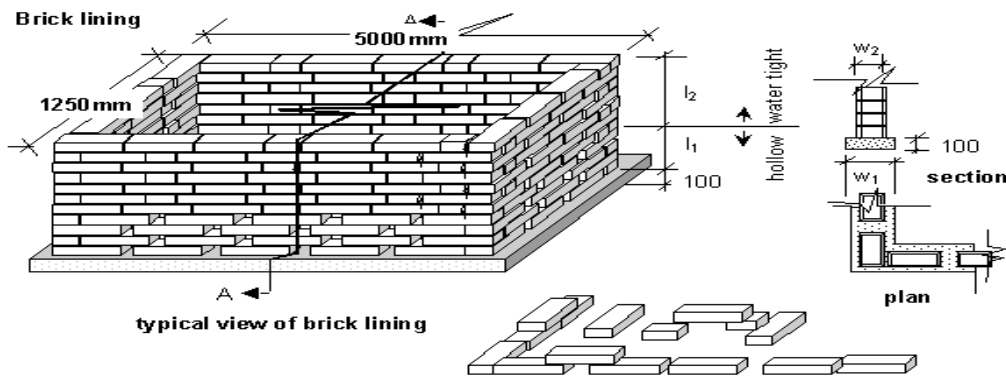

w_1 = width of the wall footing, if the wall is made of standard bricks, it will be 250mm. If the wall made of hollow blocks then it will be 300mm.

w_2 = 125 for brick wall, 200mm for hollow blocks

l_1 = height of the hollow portion to allow liquid to penetrate in to the ground. 1/3 of the total height

l_2 = height of upper sealed part, 2/3 of the total height

Minimum inner width of the pit = 1000 900mm to fit Oxfam plastic slab.

Length depends on the number of cubicles, but not more than 6000mm

Depth maximum 1500mm for unreinforced wall, and reinforced hollow block depth 2000mm

If lining a trench then it is recommended to have a hollow cross wall every 1m.

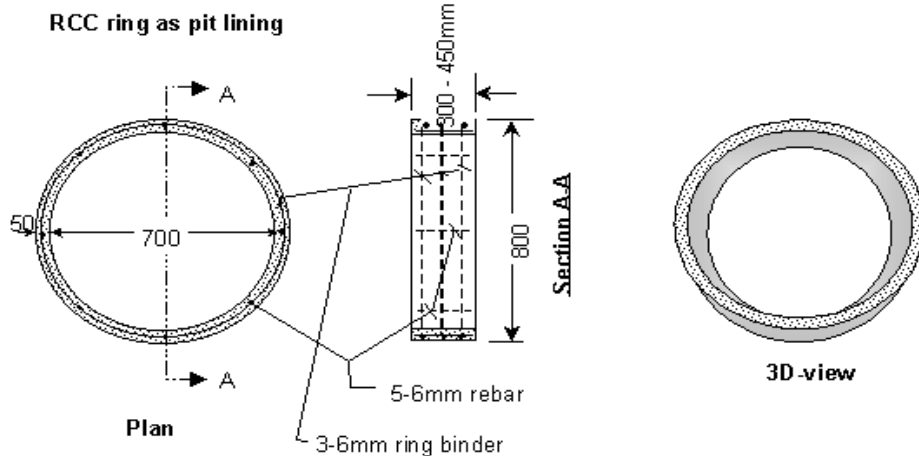

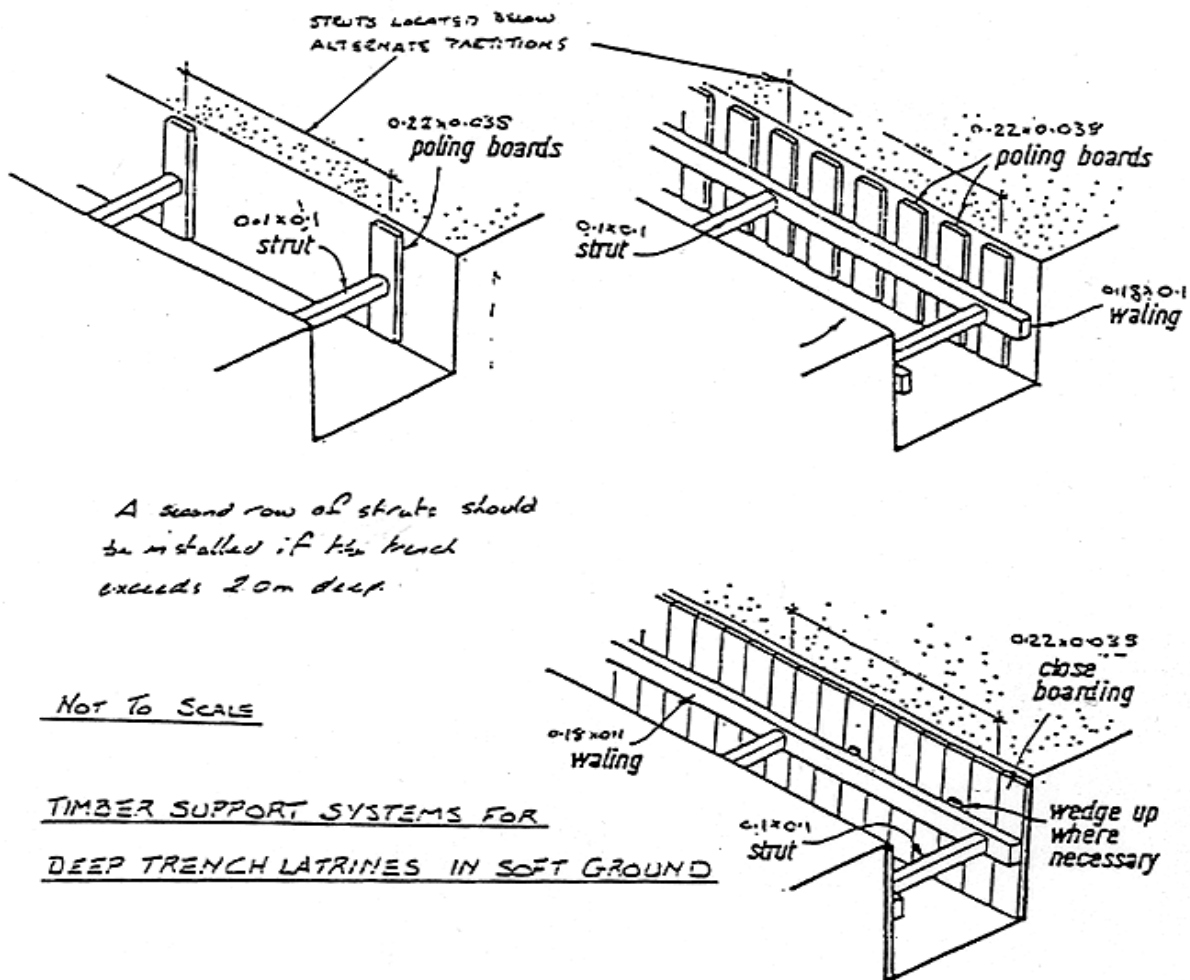

4.3 Designs for communal latrines

In emergency situations speed of construction is one of the most important factors along with an appropriate design that the beneficiaries will use. In the 1st phase the Oxfam Plastic Slab kit, Oxfam code LOP/1 and Superstructure kit, LST/1, could be used but for the longer term the community must be involved in the selection of an appropriate design. As a general rule try to design a latrine as similar as possible to that usually used by the beneficiaries. Annex 2 contains some examples of slab designs. Normally the choice of latrine slabs are as follows;

Slab Type	Comments
Oxfam Plastic Slab (LOP/1) Size 1.1m x 1m	Needs no supporting timbers – just need to ensure the pit edges are stable and place it on hole. Trench must be 90 cm wide as slab length is 1.1m. Superstructure kit designed to fit slabs.
Monoflex Plastic Slab (LP/1) Size 0.8m x 0.6m	Not big enough for cubical alone, need to construct platform to place slab on which makes it more expensive & time consuming than the LOP kit. Hole covers rapidly go missing. Use the LOP wherever possible.
Wooden Slab	Can be quick if materials available locally, not easy to clean. Prone to termite attack and rotting. Not a good long term solution. (Deforestation issues)
Bush sticks covered with packed earth	Can be fast and cheap, good to put plastic sheeting over the sticks under the mud. Can be easily upgraded with a SanPlat concrete slab or plastic slab. Difficult to keep clean, badly affected by rainfall or people washing in the latrine. Wood rots over time.
Dome Slab (LS/3) 1.2m diameter	Needs proper mould, 1 bag of cement (sand & gravel) per slab, no rebar. A good longer term solution.

SanPlat Slab (LSP/1) Size 0.6m x 0.6m	Good for upgrading log/mud slabs. Quick to produce, doesn't need rebar.
Ferro Cement Slabs	Can make slabs thinner, therefore cheaper, than traditional concrete slabs.
Concrete Slab - various sizes	Require rebar, which can be difficult & expensive to purchase. Large slabs are not easily transportable.
Plywood Slab	Water resistant ply is very expensive. Not always easy to purchase.

Ventilated Improved Pit latrines (VIP) are not recommended for the first phase of emergencies as they take longer to construct and require more materials and general maintenance. For family latrines VIP latrines are not as easy to replicate as ordinary pit latrines because the 4" vent pipes are normally too expensive, are often not maintained and therefore cease to function as VIP latrines. Common problems are that;

- The netting over the vent pipes is ripped or lost.
- People put a cover over the hole (although a loose fitting lid may still allow for air currents)
- There is insufficient ventilation which inhibits the circulation of air
- The cubicle is too light, attracting flies up the squat hole instead of up the vent pipe.
- The latrine is sited where the sun is unable to heat up the vent pipe, which also inhibits the air circulation

If constructing VIP latrines special attention needs to be paid to avoid the common problems described above. The beneficiaries need to understand how the latrine should function in order to maintain it properly. The vent pipe needs to be at least 10 cm in diameter and approximately 0.5m above the level of the latrine roof. The vent pipe should also be in a sunny position, painted black and have gauze over the top of the pipe to improve upward vector currents.

Diagram of a simple wooden superstructure

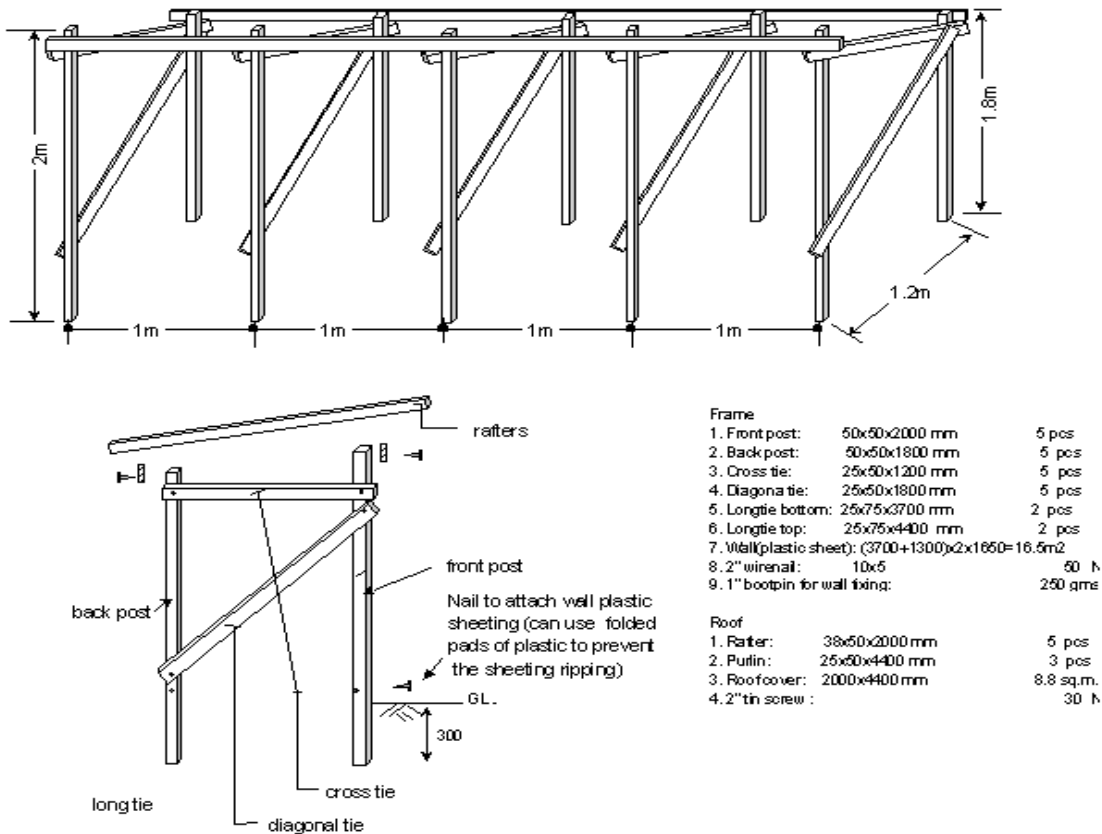

5.0 FAMILY LATRINES

The aim of the family latrine programme, which may involve up to 4 families sharing one latrine,

is to provide a minimum coverage of 20 people to one latrine thereby improving latrine maintenance and use.

In the Burundi refugee camps in Rwanda Oxfam designed family latrines following consultation with the beneficiaries. The family latrines were to be shared between four families and had separate cubicles for men, women and children. The children's latrine was left open and provided a smaller squat hole with a surrounding bar for the children to hold onto.

There are a number of ways of achieving this:

- The entire latrine can be constructed by the agency
- The beneficiaries can dig their own pit & the agency provides the slabs, superstructure and technical assistance.
- The beneficiaries are mobilised to construct their own latrines using locally available materials. The agency may need to provide tools and technical assistance

Normally some combination of the second two options is attempted and this involves employing a large number of public health promoters or volunteers to mobilise the community to get the work done.

In Rwanda in 1996 the Gikongoro camps were divided up into areas of roughly 2000 - 2500 people with teams of workers responsible for that area. For each area there were approximately 10 sanitation workers and 6 public health promoters. The sanitation workers mobilised families to dig their own pits and Oxfam provided ready made wooden slabs and in certain camps provided plastic sheeting, grass or bamboo mats and wood to build the superstructure. In other camps such as Karagwe in 1994-96, families were motivated to construct the superstructure with locally available wood and vegetation. There should be at least 1 sanitation worker/community mobiliser per 500 people.

The pit should have a diameter of 1m, a circular hole is more stable than a square hole and be approximately 2m deep. The pit should normally be lined around the top 50 cm to prevent collapse and have a small, 20cm ridge around the top to prevent runoff going down the hole. In high rainfall areas roofs will be necessary but once again there should be consultation with the community on this point. Roofs can be made of plastic sheeting, split bamboo, concrete or zinc sheeting.

Low Cost bamboo superstructure

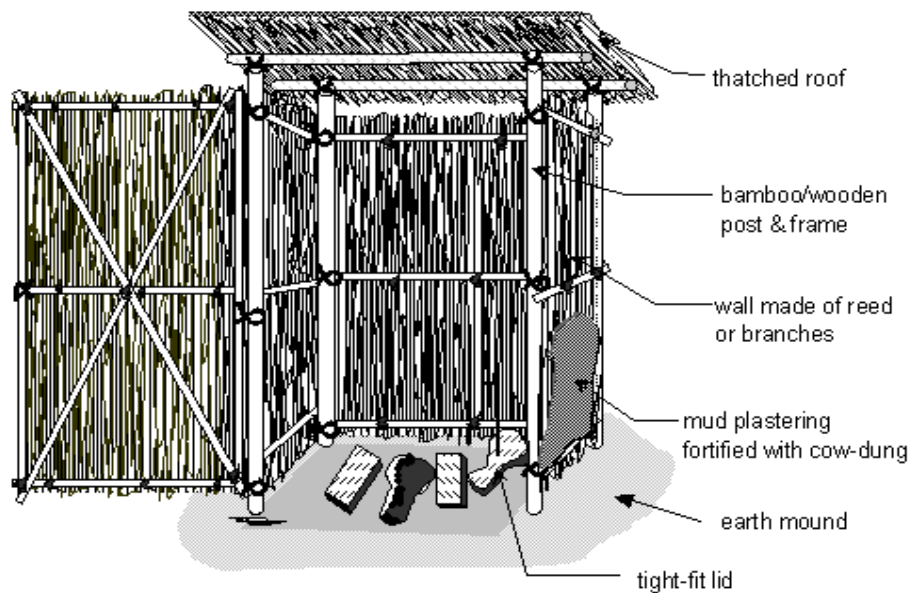

low-cost superstructure

Spiral Superstructure

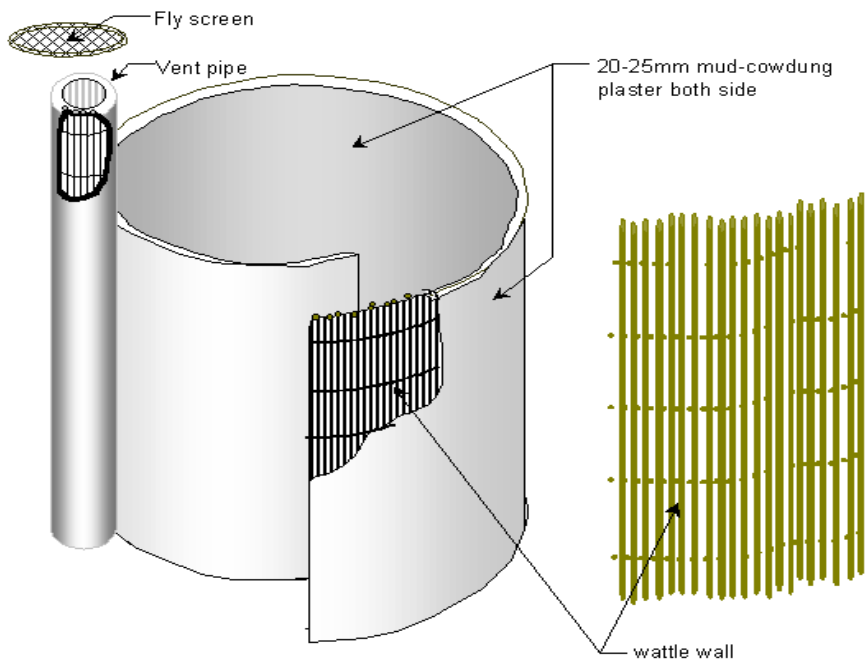
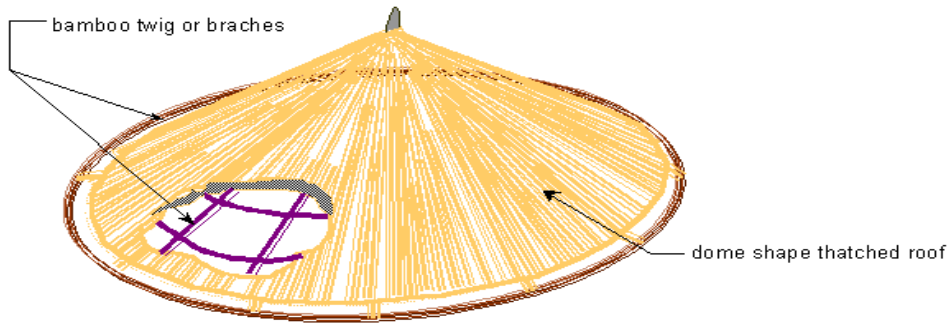

Spiral superstructure

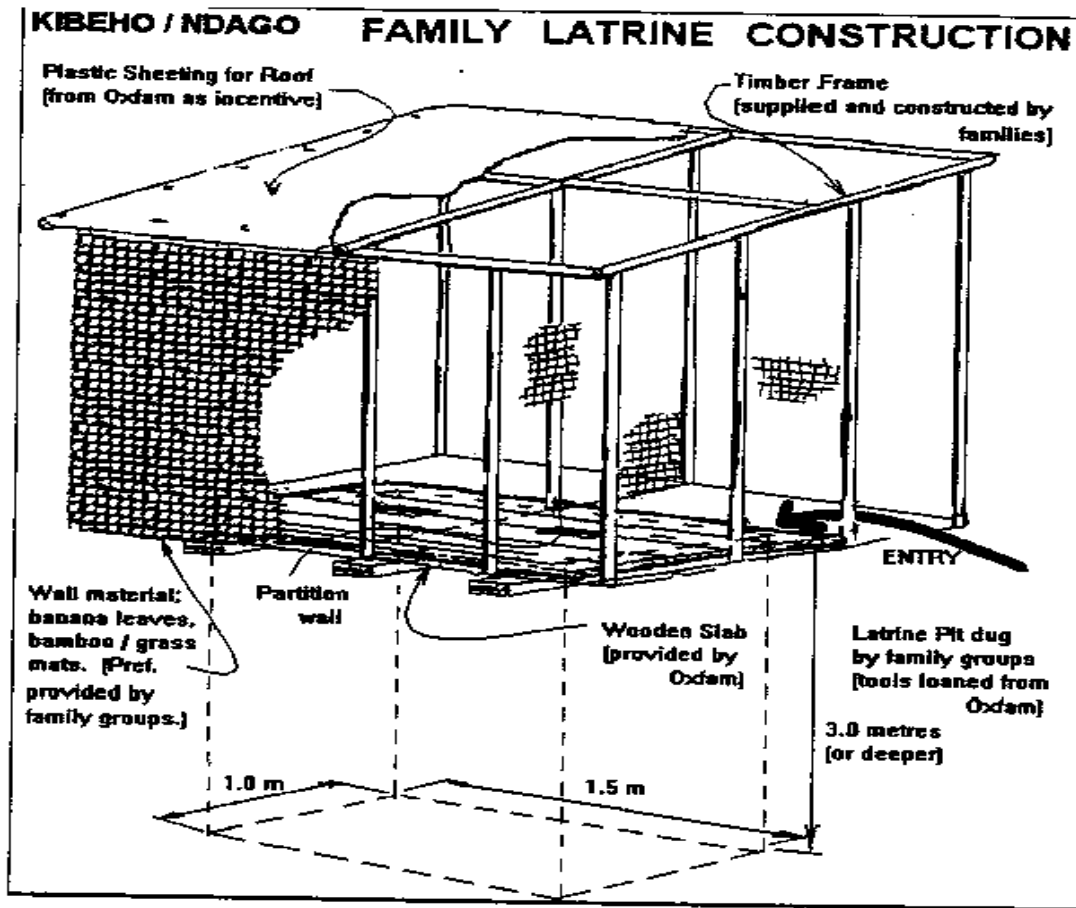

6.0 LATRINE OPERATION AND MAINTENANCE

6.1 Anal Cleansing Material

All people use some form of anal cleansing material and it should not be assumed that the population will have their own supply. Materials range from water to stones, leaves, corn husks and paper. However, while recognising what people traditionally use, they may need to be encouraged to use more available materials such as paper or water, in a densely populated site. It may be necessary to provide people with cleansing materials and for an appropriate method of disposal.

In the refugee camps in Albania and Macedonia in 1999 there was a major problem with people disposing of plastic water bottles in the latrines. This meant that the toilets quickly became unusable. In some camps bins were provided but what was needed was an information campaign to ensure people knew why it was important not to throw the bottles down the pits.

This should be done in conjunction with the public health promoters who should also promote such things as hand washing after defecation and after handling infant's stools.

6.2 Cleaning and Maintenance

It is vital that the families are involved in the process right from the beginning as if they are not they may not feel responsible for the cleaning and maintenance of the latrine and the project will not fulfil its objectives.

When cleaning avoid putting disinfectants such as chlorine into the pit as this inhibits the natural biological degradation of the excreta. Putting ash or soil down the pit can reduce flies and odours. Unless VIP latrines are being built covers will be necessary to limit fly breeding. The effective use of the covers will again depend on the skill of the public health promoters in motivating the community.

6.3 Fly Reduction

Fly larvae (maggots) will develop in various collections of organic matter and different flies prefer different conditions. Chrysomya prefer open latrines and animal excrement whilst Musca Domestica (housefly) will

breed in a variety of conditions from garbage tips to human excrement. Between five and ten thousand flies will breed in one kilogram or one litre of organic matter. They usually have a lifespan of one to two months. They are capable of transmitting dysentery, infantile diarrhoea and typhoid although are rarely involved in the transmission of cholera.

Lids should always be provided for squat holes except in the case of VIP toilets where a lid can interfere with the air currents. Putting large quantities of ash into the hole may help to reduce fly breeding. ...can also be used. Insecticides should only be used when absolutely necessary and as a short term measure as flies quickly develop resistance and insecticides applied to latrines may prevent the decomposition of faeces. However insecticide may be sprayed on the walls of the superstructure if necessary. Larvicides – chemical and biological.

6.4 Sanitation corridors

In a refugee camp scenario it is advisable for the sanitation engineer to liaise as closely as possible with the camp planners to ensure that there is space allowed for latrines, family or communal. An efficient way of doing this is to have sanitation corridors as the diagram below illustrates.

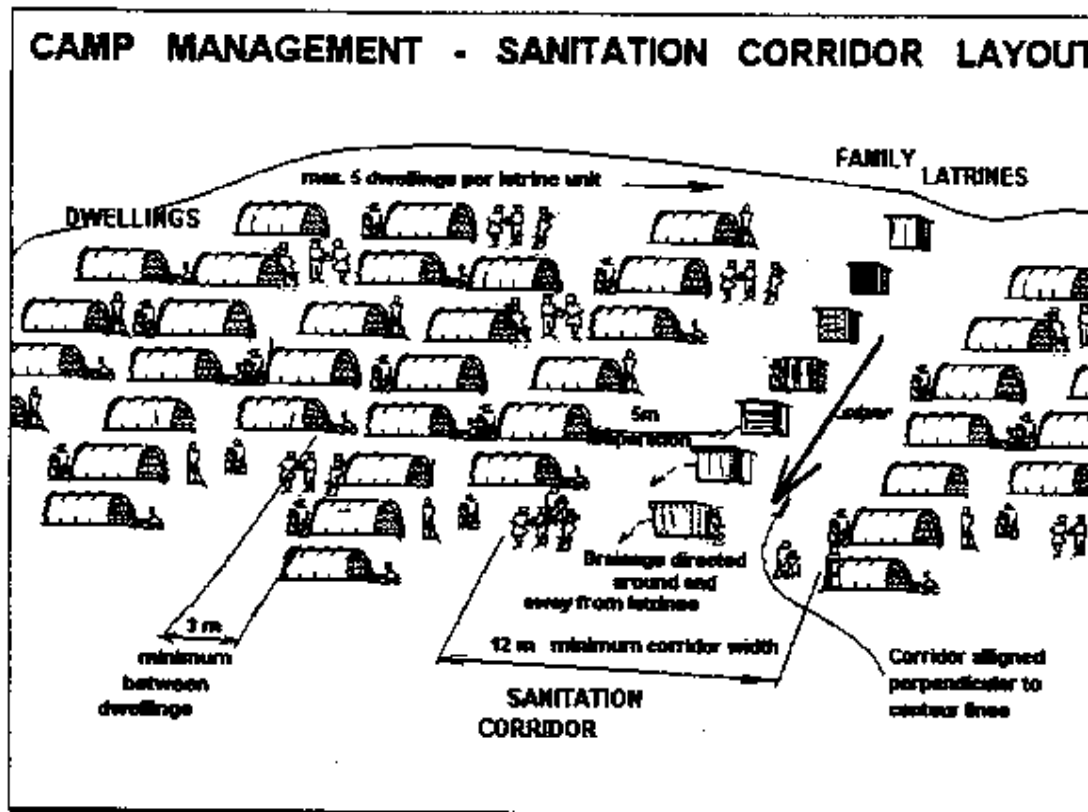

6.5 Latrine desludging

Desludging should be considered in situations where;

- Land availability is scarce, i.e. it is not possible to dig another pit nearby when one is full.
- Ground conditions have meant that raised latrines have had to be built: e.g. high water table, impermeable ground or rock areas.
- Latrine pits have been lined.

If latrines are to be desludged, then either the hole in the squatting slab needs to be large enough to allow a hose through for pumping or a removable slab or a removable cover, outside the cubicle, needs to be made to allow a hose or a person to enter. The preferable option is a removable cover so that solids that cannot be pumped out can be dug out and any spillage during desludging does not contaminate the inside of the latrine. Many cultures have a tradition of hand emptying pits but in densely populated refugee camps this should be avoided if possible. In Katala Camp, Goma in 1995, latrines were emptied using buckets which were subsequently emptied into 200l drums on 3 ton trucks, which disposed of the material in a dump some 6 km away. 100m³ sludge for 150,000 people was evacuated every week using this method.

Other options are mechanical. There are now hand operated pumps and small motorised pumps which are capable of sucking up the excreta slurry into small mobile tanks. There is a whole range of pumps, diesel or electric, which can pump slurry from pit latrines into tankers or adapted vehicles as well as the specifically designed suction tankers. Oxfam Kit WSDP/6 is an electrical submersible sludge pump which is capable of desludging pit latrines. It has a metal grill to prevent large bits of rubbish, bottles, bones etc clogging up and jamming the impeller. If extra pumping head is required these pumps can be put in series. This kit could be used to pump slurry into ex-water tankers, barrels or metal tanks mounted flat bed trucks, tanks for transportation to a disposal area. The aim of this type of desludging is not to remove everything from the latrine only the slurry component. Removing the top 2/3 of the pit could extend the life of the latrine by a few years – eventually the compacted solids will have to be dug out by hand.

7.0 LATRINES IN DIFFICULT ENVIRONMENTS OR SETTINGS

The technical solutions for latrines in areas where there is a shallow water table, areas which are flood prone or are very rocky, are limited. If conditions are obviously unsuitable a strong case may need to be made to support the movement of people to a more suitable site. However, often there is no other option to these sites and alternative solutions will need to be found.

7.1 High water tables

Classically the solution is to build raised latrines or to build watertight tanks. To prevent contamination of the ground water the bottom of the pit should be at least 1.5m above the water level. In areas of very shallow watertables it is very important to ensure that any ground water sources are up-hill and more than 30m away from the latrine. In these situations it is especially important to know how many people will be using the latrines and to calculate the rate of solid and liquid accumulation in the pit, so often pits are larger than they need to be. A large number of small capacity latrines, wide rather than deep, are preferable to a few large capacity latrines. Trenches can be dug to take off the liquid effluent in pipes as in soakaways and septic tanks.

The pits can be dug to 1.5m above the level of the water table then raised using bricks, blocks, stone, concrete rings, corrugated iron calverts or earth mounds. Using the same concept mounds or platforms could be built whereby people can defecate directly into buckets or drums which can be emptied manually.

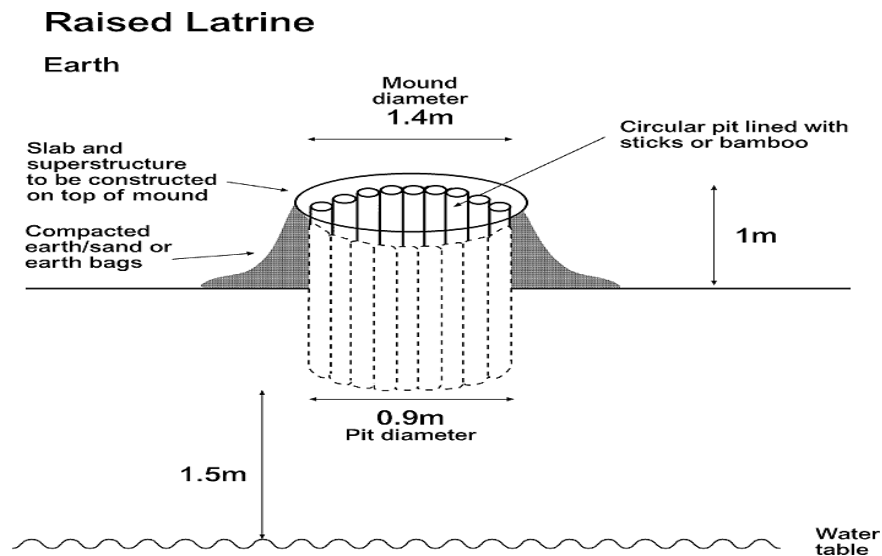

Raised Block Latrine

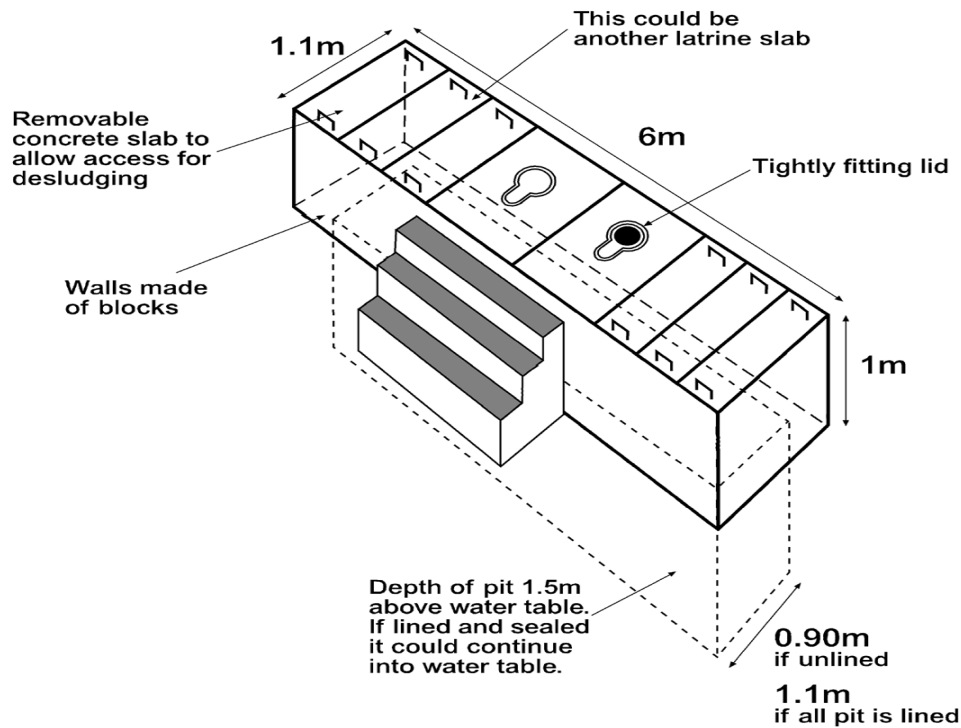

If the areas where the latrines are prone to seasonal flooding then the pits need to be sealed to stop the sewage mixing with the ground water and polluting water sources. This can be done with cement plastered bricks or blocks, ferrocement or concrete rings. Where flooding can be excessive tight fitting lids should be put in the squat hole so that the sewage cannot rise up out of the hole.

Summary of possible solutions in high water table/flood prone areas;

- 1) Raised latrines, normally only 1 – 1.5m above ground level.
- 2) Sealed pits/sealed pits with soakaways/septic tanks – the pits may need dewatering before construction can go ahead. 1 m³ precast ferrocement tanks could be manufactured fairly easily with the appropriate fittings for desludging.
- 3) Portable chemical toilets – expensive, uncommon outside Europe, requires regular desludging
- 4) Bucket latrines – Setting a number of large buckets/containers or barrels, soil with a squatting slab of some sort over the top so people can defecate in them. These could be mechanically desludged daily. needs a good safe system of bucket collection & safe eventual disposal of excreta..
- 5) Plastic bags – used during the 1998 Bangladesh floods, people would defecate in plastic bags and then float them away. If the bags are not collected and disposed of properly or a river does not take them out to sea this would constitute a serious health risk.
- 6) Low cost sewage system – if there is sufficient water available pipes, from 8” diameter to 3m diameter drainage type pipes, then people can defecate directly into special holes in the pipe and water would be released periodically to wash the sewage into a sump for desludging or for pumping out to sea. Washing areas could also be plumbed into these sewage drains to help the effluent flow.
- 7) Sewage treatment system in Oxfam tanks – high tech high cost system.

7.2 Rocky areas

All the above suggestions are also applicable to rocky areas, in addition for the first phase in areas where the ground is extremely rocky making it virtually impossible to dig trenches, **intensive defecation areas** may be needed, as described below. Also, in Goma in 1994 the Public Health teams tried to use existing fissures in the rock for excreta disposal but they become full very rapidly. If using rock fissures then extra care should be taken that it is not contaminating an aquifer. If mechanical diggers are available larger pits can be excavated in soft and brittle rock and these can be adapted into septic tanks.

7.21 Intensive defaecation fields

In very rocky areas where faeces cannot be covered with soil a variation on the defaecation field may be used. Each time a person goes to use the defecation area they are given a shovel with a cupful of burned lime to take with them. They then sprinkle half of the lime on the sand before defecating on top. The other half of the lime is used to cover the faeces, which is then scooped up on the shovel and taken out to be put in a covered container in the aisle at the side of the fenced off area. Staff empty the containers into the pit, or load them onto a truck for disposal elsewhere. As with other public toilet facilities, water and soap should be provided at the defecation area for washing hands. When the sand layer becomes depleted as users scoop up faeces, it should be covered again. This method was used in Goma in 1994.

7.3 Transit Camps

Whilst people often do not stay long in transit camps it remains important to provide adequate, accessible, safe and culturally appropriate toilets. Latrine attendants will probably need to be employed and equipped with cleaning materials. Handwashing facilities should also be provided and latrine attendants should encourage people to make use of these. Many of the latrines built in the transit centres in East Timor were never used because they failed to fulfil these criteria.

7.4 Feeding Centres

Latrines built in feeding centres will be used not only by the children using the centre but also by their parents or carers. It will therefore be necessary to build more latrines to accommodate the heavier demand or ensure there is enough space available to dig further latrines once the initial ones are full. Latrines will also need to be suitable for children's use (see above) and systems for the cleaning of the latrines will need to be set in place. Child friendly handwashing facilities will also be necessary (e.g. a tippy tap). Older children or carers should accompany children to the toilet and ensure that children wash their hands. Potties (preferably with lids) will also be necessary but adequate disposal and cleaning is vital to prevent the transmission of disease.

7.5 Urban Environments

It is particularly difficult to provide effective excreta disposal when working in a large urban environment. Normally, the first strategy would be to make use of or rehabilitate any existing latrines, this may involve isolating part of the sewage system if some parts are damaged. If there is large scale damage to the sewer system try and locate septic tanks and set up temporary latrines which feed into them. In some situations it may be possible to hire portable toilets, however, they do require desludging almost daily in crowded sites. Therefore, only consider hiring portable toilets if it can be guaranteed that regular desludging can take place. Other technical solutions are to use concrete calverts, by blocking off the ends of a row of calverts, digging them in to the ground and making squat holes in the top of the calverts. If it is all set on a slight gradient then the "tube" can be desludged from one end. Tanks such as Oxfam tanks can also be dug into the ground and used as desludgable excrement containers.

It is better to concentrate on communal areas such as markets or transit centres rather than hope to provide family latrines for everyone. Discussions with community groups should help to identify where the risks are and whether there are possible solutions such as several families sharing one latrine or public latrines at key locations. In a semi-urban settings it may be possible to dig communal pit latrines or if people are willing and able to dig their own latrines and provide the superstructure, it may be possible to provide each family or at least vulnerable families with a latrine slab.

7.6 Borehole latrines

Borehole latrines can be very quick to construct if there is an auger. A deep soil profile (>7m) is required which is relatively easy to drill with a hand auger or a mechanical drill. Normally the hole would be up to 500mm diameter and 7m metres deep. A hole 300mm diameter and 5 metres deep should last a family of five approximately 2 years depending on the material used for anal cleansing. Borehole latrines can be constructed very rapidly if an auger or a drilling rig is available, however, often the side walls become fouled which can smell and encourage fly breeding. As these latrines are deeper than pit latrines there is more chance of contaminating the ground water.

8.0 MONITORING AND EVALUATION

The process of monitoring and evaluation should be started as soon as the latrine programme starts. The responsibility of the engineer does not stop with the completion of the toilets but with their effective use and maintenance. Initially monitoring can be done in the form of weekly reports as shown below:

Corridor No	Name of sanitation worker	Name of local responsible	No of dwellings	No of latrines	Conditions of latrines	Latrines under construction	Target No.	Instructions	Comments

Such a report does not however tell us if the latrines are actually being used or how the community are responding in terms of construction and maintenance. The public health promoters along with the sanitation team need to find this information by observing the people and talking to them individually or in informal groups. The public health promoters could also maintain monitoring forms or family members could be encouraged to maintain their own monitoring form for each latrine and to report any problems to the public health promoter. An example of a monitoring form is given in the appendix.

Community could also be involved in identifying health risks using the kind of map used in the initial assessment. Areas of open defaecation, full latrines, maintenance problems etc could be identified on the map. In this way community members are also able to observe if any improvements have been made. Make sure that maps are constructed with both men and women. Children may also have fun constructing maps. In one project in Bangladesh children put real red flags in areas where there was indiscriminate defaecation and so shamed other people into taking more care. The responses from such surveys should be discussed between the sanitation team and the public health promotion team to ensure there is a joint approach to using this monitoring data to improve the effectiveness of the project.

9.0 QUANTITIES AND COSTS OF SUPPLIES NEEDED FOR LATRINE PROGRAMME

The spreadsheet in appendix 1 is an example of the process of working out how much material will be needed, how much it will cost and how long it will take to complete. This spreadsheet can be modified to suit most situations.

Local materials should be used whenever possible rather than importing materials but this may not be possible initially in an unstable and critical environment when speed is vital. Below is a cost comparison of 3 materials used for latrine superstructure.

Kibeho Camps, Rwanda, 1995

Material	Unit	Unit cost (US\$)	m ² per unit	Cost per m ² (US\$)	Cost per double latrine approx. 14 m ²	Comment
Plastic sheeting	Rolls	175	50m x 4m	0.87	12	Imported
Grass mats	Mat	0.73	2m x 2m	0.0018	0.025	Local
Bamboo mats	Sheet	1.2	4m x 2m	0.14	1.96	Local

Further Reading:

J.Davis and R.Lambert (1995) Engineering in Emergencies: A practical guide for relief workers, London: RedR/IT Publications

MSF (1992) Public Health Engineering in Emergency Situation, Paris, Medicines sans Frontieres

J.Adams, (1999) Managing Water Supply and Sanitation in Emergencies, Oxfam.

S. Ferron, (2000) Oxfam Public Health Promotion in Emergencies Guidelines

J.Pickford (1995) Low Cost Sanitation: A survey of practical experience, London: IT Publications

Sphere Project (1999) Humanitarian Charter and Minimum Standards in Disaster Response, Geneva. SCHR

Small Scale Sanitation (1988) Sandy Cairncross, Ross Institute Bulletin No 8

P.Morgan (1990) Rural water supplies and sanitation, Zimbabwe: Macmillan

IRC (1991) Just Stir Gently, The way to mix hygiene education with water supply and sanitation, The Hague:IRC

IRC (1984) Making the Links. Guidelines for Hygiene Education in Community Water Supply and Sanitation, The Hague:IRC

U.Winblad and W.Kilama (1985), Sanitation without Water, SIDA/Macmillan

WHO (1998) Sanitation Promotion Kit, Geneva:WHO

Oxfam Sanitation kits

LD/2 - Latrine digging kit

LF/1 - Defecation field/trench kit

LOP/1 - Self Supporting Plastic Squatting slab kit

LS/3 - Dome slab construction Kit

LSP/1 - SanPlat latrine mould

LST/1 - Latrine superstructure kit

Appendix 1 – Estimates for labour and materials for latrine construction

Appendix 2 - Slab designs

Appendix 3 – Designs for hand washing facilities

Appendix 2 – Slab Designs

Dome Slab – Oxfam Code LS – 1.2m diameter slab

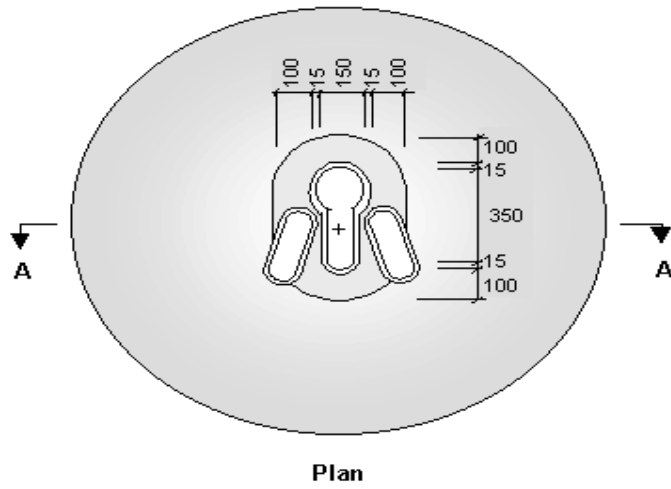
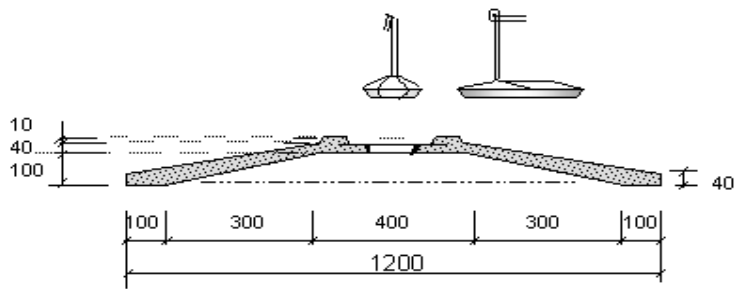

Square Slab – 1m by 1m

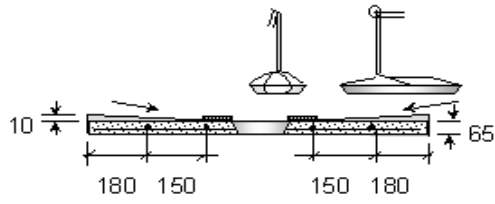
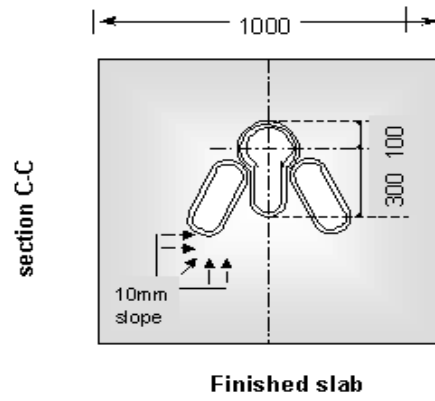
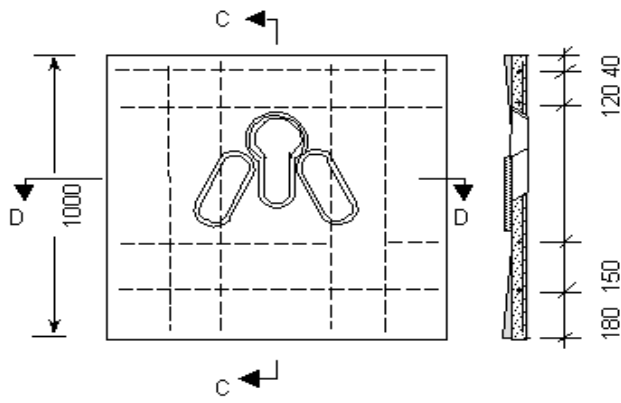

section D-D

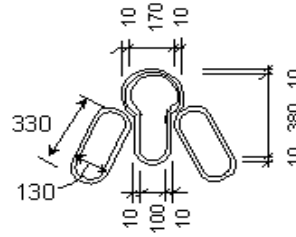

Ferrocement slab

Ferrocement slab with pour-flush bowls

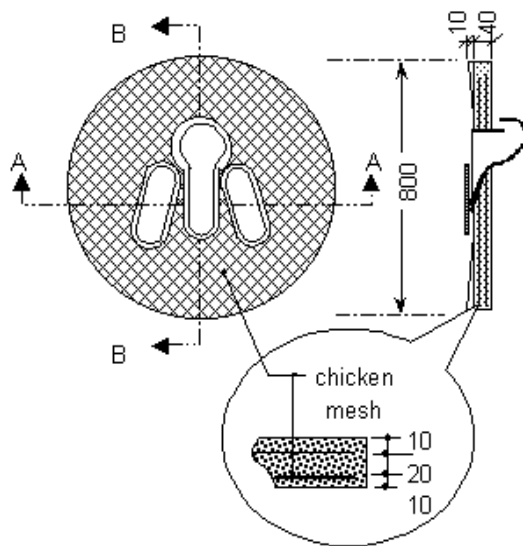

section: B-B

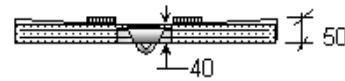
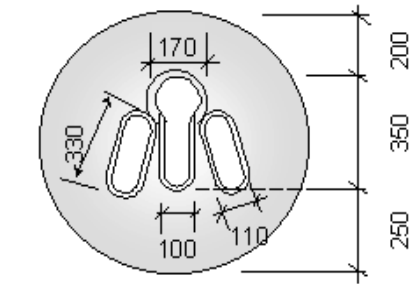

section: A-A

Wooden Slab

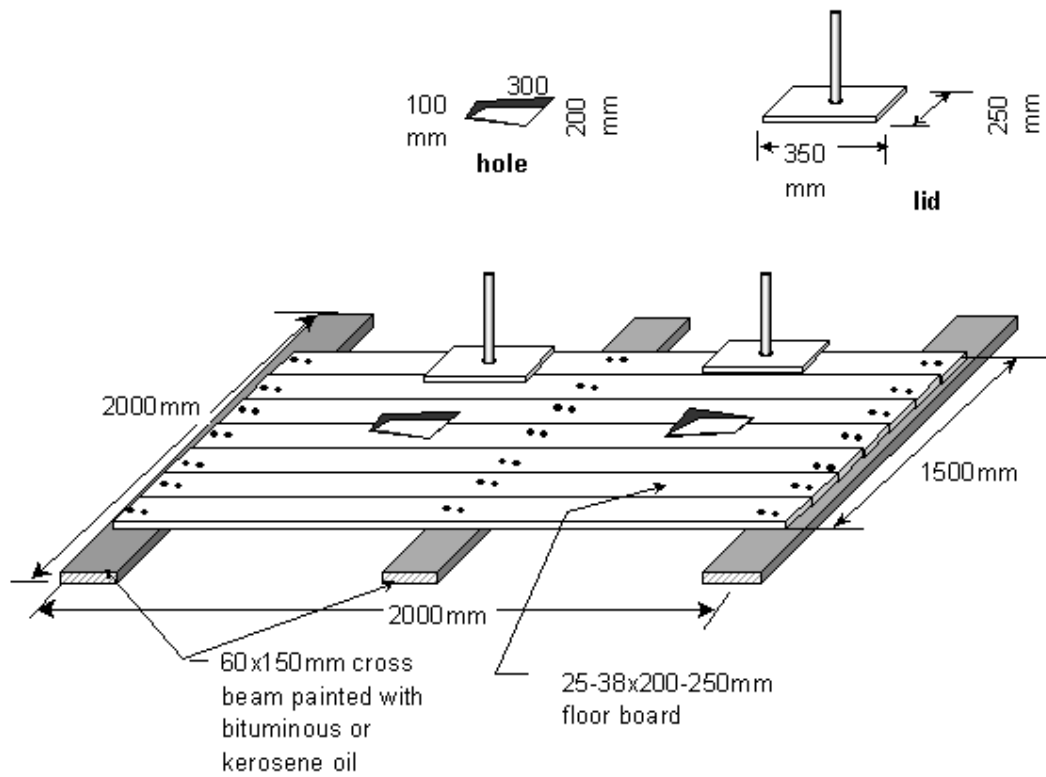

Wooden slab for twin compartment latrine

Timber

- | | |
|------------------------------------|-------|
| 1. 60x150x2000mm joists across pit | 3 pcs |
| 2. 38x200x2000mm floor board | 7 pcs |
| 3. 25x250x350mm lid board | 2 pcs |
| 4. 25mm dia x 500mm lid handle | 2 pcs |

Hardware

- | | |
|---------------------------|---------|
| 5. 75mm tall wire-nails | 42 pcs |
| 6. Bituminous or kerosene | 0.5 ltr |

Appendix 3 – Handwashing designs

