



---

# ACCESSIBILITY FOR ALL IN AN EMERGENCY CONTEXT

---

*A guideline to ensure accessibility for temporary infrastructure, WASH facilities, distribution and communication activities for persons with disabilities and other vulnerable persons*

**HANDICAP  
INTERNATIONAL**

## ***Introduction:***

This practical guideline is for the use of all emergency stakeholders in all sectors. It provides technical guideline for physical and communication accessibility to ensure that persons with disabilities can access all emergency facilities.

7 to 10% of the general population lives with a disability.

Even if you do not see them, Persons with disabilities exist and have the same needs as others but may need specific support to meet these needs.

Older persons, pregnant women, children and other vulnerable persons will also benefit from these adaptations.

## **COMMUNICATION ACCESSIBILITY FOR ALL**

Make sure all information you want to communicate can be understood by everyone. For example, a person who can not see will not be able to read banners or posters while a person who cannot hear will not be aware of information broadcasted on radio or loudspeakers.



- Use at least 2 means of communication !
- Use simple language and clear pictures
- Use large dark print (at least 10 cm letters for 3m viewing distance/ 20 cm for 10m distance)
- Don't forget to light up signage at night.
- Put your information materials in easily accessible areas/ Make sure your broadcasted information will be loud enough to reach persons who cannot leave their shelter.

# ACCESSIBLE TEMPORARY INFRASTRUCTURE

Design and build camps and temporary settlements using minimal accessibility principles (based on Universal design) to make them SAFE et USER FRIENDLY for ALL. Adapt the environment according to the needs of the affected population: Shelters and public facilities such as camp offices, health services and other communal areas.

Consult people with disabilities and their families when designing temporary infrastructure.

## Technical Recommendations:

- Make sure the pathways are stable, firm, even, and slip-resistant, and at least 90 cm wide.
- Ensure that there are no steps at the shelter entrance and the doorways are at least 90 cm wide (not including the frame).
- Make sure tent ropes or other obstacles are not blocking pathways.
- A ramp is always better than stairs, the ideal gradient should be 1:10 and it should have a smooth and non-slip surface.
- If you build stairs, make sure they are not more than 16cm height and at least 26cm depth.
- Doors should open outwards to increase usable space inside.

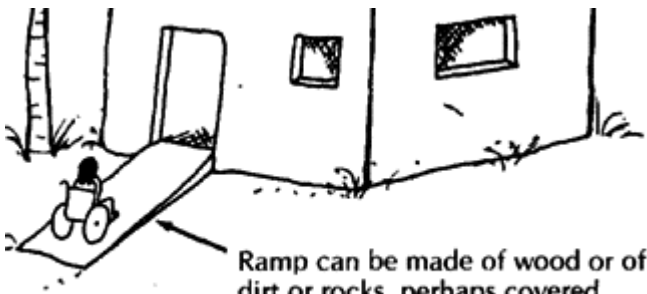

Ramp can be made of wood or of dirt or rocks, perhaps covered with a thin layer of cement.

## ACCESSIBLE TEMPORARY INFRASTRUCTURE

- Don't forget to use bright paint if possible to indicate change in elevation/direction.
- If the people are sleeping on the floor, make sure to provide some raised beds for people with less mobility.

**Locate person with disabilities and their families close to essential facilities (latrine, distribution point, water point, cooking areas...**

**ALWAYS BUILD HANDRAILS (90cm height)  
BESIDE STAIRS AND RAMPS.**

**A SIMPLE ROPE HANDRAIL CAN BE USEFUL FOR  
GUIDING PERSONS WITH VISUAL IMPAIRMENT  
EVEN ON FLAT GROUND .**

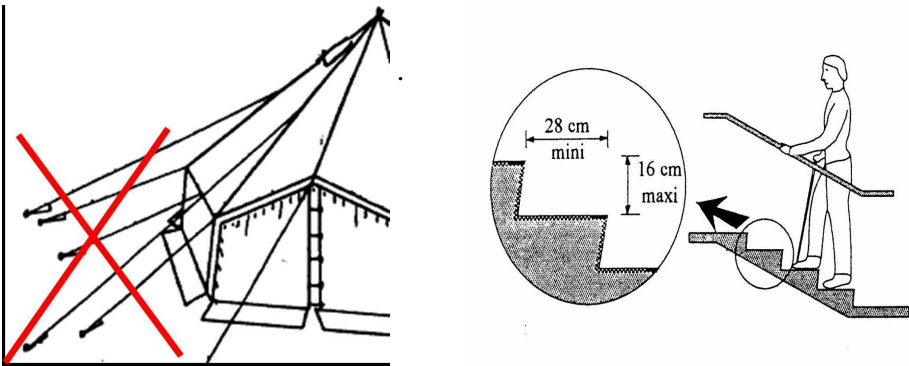

**If accessibility features are incorporated into the original design of a building it usually costs less than 2% of the total cost of the construction.**

# WASH FOR ALL

WASH facilities are basic needs and must be usable by all.

## General Recommendations:

- At least 10% of the WASH facilities should be accessible
- Rough surface to avoid slipping
- Entrance to latrines and enclosed bathing areas should be at least 90 cm wide (not including the frame).
- All taps and door handles should be easy to grasp.

## Technical Recommendations for latrines:

- Build something to hold when using latrine (handrails, rope...). For handrail, the middle point should be between 50 and 70cm height and 40cm length.
- Build some latrines with an elevated seat (50cm from the finished floor level for an adult ) or provide toilet chairs

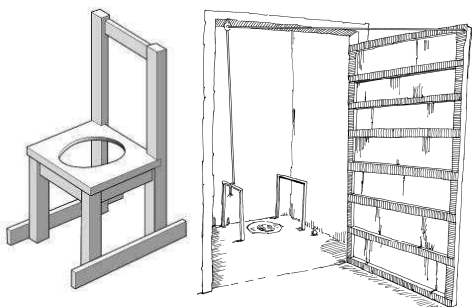

## Technical Recommendations for bathing and laundry facilities:

- Provide a seat or bench (60 cm height) and handrail (110 cm height) for persons needing additional support.
- Ensure the area is enclosed for privacy reasons.

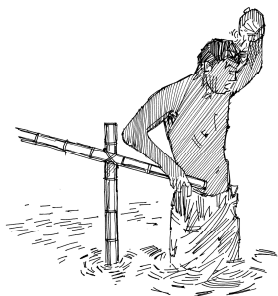

## WASH FOR ALL

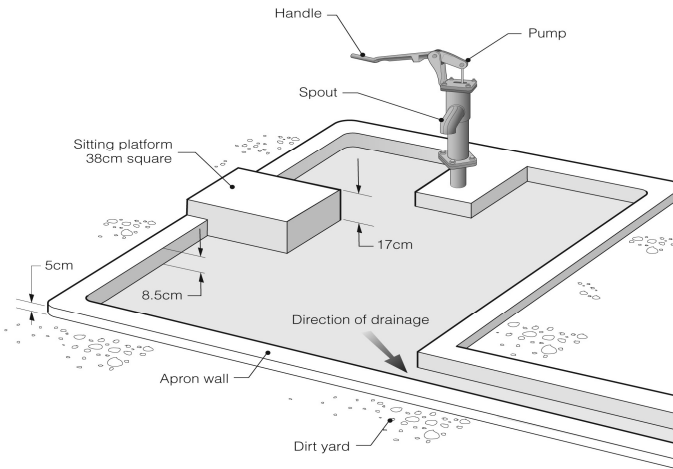
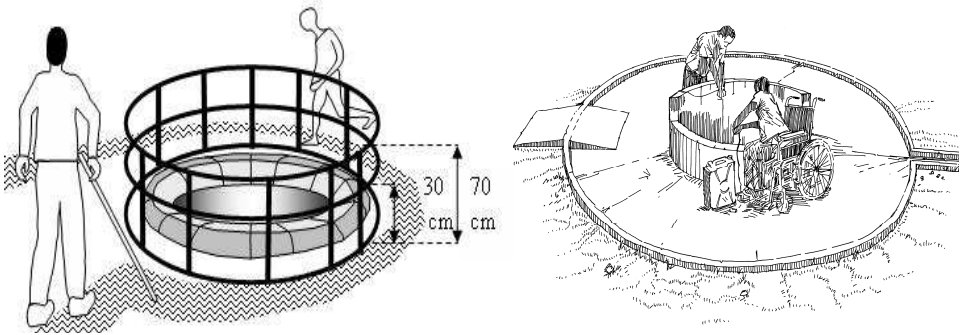

### Technical Recommendations for water points:

- Be sure the water source is safe and can be reached by people using mobility devices.
- The water drawing mechanism (pump or pulley), should be easy to operate from outside and inside the platform.
- Extend the handle of the water pump (105 cm) or if a well is being installed, ensure the rope is at a height which can be easily reached.
- Construct a non-slip platform and good evacuation/drainage system without standing water in and around the area.
- Consider building a small raised platform so that someone can sit and pump water.

*For more information, documentation or technical support on this issue, please contact  
**HANDICAP INTERNATIONAL***

## DISTRIBUTION FOR ALL

Not all the people with disabilities or injuries will be able to come to central distribution points; develop alternative mechanisms to reach them.

- Locate distribution points where people with disabilities/ injuries are staying.
- Organize specific line-ups for persons who can not stand for long periods.
- If this is not possible, consider « home » (door to door) distribution.
- Help the person to carry their ration or relief items (for example, a smaller parcel size, arrange transportation or a helper).
- Provided adapted water containers and eating utensils



- Monitor that the person receives all of his/her rations and that a part does not go toward « payment » of the helper.
- Adapt quantity and type of general Non Food (blankets/ mattress etc.) and Food (high energy food) items distributed.

## HANDICAP INTERNATIONAL

### Philippines:

Tel: +63 (2) 812 6990 / +63939 3981568

Fax: +63 (2) 817 0147

42, Ponce Street, San Lorenzo Village

1223 Makati City, Philippines

hi.astcoordo.manila@gmail.com

### HQ:

Emergency Response Department

+33 (0) 4 78 38 40 20

office@handicap-international-atlas.org

Produced by:



2009

*Many thanks to Handicap International, Hazel Jones (2005, WEDC) and Disabled Village Children for the illustrations. This booklet has been developed from a number of Handicap International resources including "How to build an accessible environment in developing countries based on the Cambodia program experience"*