

# Low-cost housing in Kenya

Precast low-cost housing with steel fibre reinforced concrete

F i n a l R e p o r t



## SpiriT

Students designing Precast Initial elements with Reinforcement Technology

Schelte de Boer, Tom Groeneweg, Greet Leegwater and Eric Pieterse

*[www.kenya.tudelft.nl](http://www.kenya.tudelft.nl)*

September, 2004



# Group information

Group number	CF23
Schelte de Boer	student number: 1004336 Transportation and Planning
Tom Groeneweg	student number: 1049542 Structural Engineering
Greet Leegwater	student number: 9505768 Structural Engineering
Eric Pieterse	student number: 1041037 Building Engineering
Website	<a href="http://www.kenya.tudelft.nl">www.kenya.tudelft.nl</a>
Supervisors	Prof. S.M. Shitote (Moi University, Kenya) Dr. H.O. Farah (Moi University, Kenya) Prof. dr. ir. J.C. Walraven (TU Delft, the Netherlands) Ing. O.S.M. van Pinxteren (TU Delft, the Netherlands)
Consultants	dr. A. Mumbo (Moi University, Kenya) J. Orowe MSc (Moi University, Kenya) dr.ir.drs. C.R. Braam (TU Delft, the Netherlands)
Sponsors	Van Hattum en Blankenvoort b.v., Woerden Schöck Nederland b.v., Apeldoorn Bekaert n.v., Zwevegem (Belgium)
Other partners	Bamburi Cement Ltd. & Bamburi Special Products Ltd. East African Portland Cement Company Ltd.



# Preface

In our Masters curriculum of the study of Civil Engineering at Delft University of Technology, there is a possibility to do a masters project. We choose to do this project abroad. With the help of CICAT we arranged a project at Moi University in Eldoret, Kenya.

This report is for whom is interested in the material of steel fibre reinforced concrete. The material will be used in precast elements, designed for residential housing in developing countries.

The participants of the Spirit-group are: Schelte de Boer, Tom Groeneweg, Greet Leegwater and Eric Pieterse. The group is multi-disciplinary and has expertise on structural engineering, building engineering and transportation & planning.

We would like to thank several people who helped us. Respectively E.W. Bol (Cicat), Prof. S.M. Shitote (Moi University), dr. H.O. Farah (Moi University), C. Sitters (TU Delft) and C. van der Veen (TU Delft), Theo Vlaar, Julius Orowe and Alex Mumbo.

September 7, 2004



# Summary

The population and urbanization of Kenya is increasing, because of this the Kenyan government has resolved to create 150.000 new houses annually. The quality of housing in Kenya is low, especially in rural areas. The prices of houses should be as low as possible so that they will be available to a large group of the population. A new quick and cheap building method would assist the government in achieving their goal.

Precast technology is a possibility to perform a quick and cheap building method. Another advantage is relatively good quality of the concrete, because of controlled circumstances. For this purpose new available techniques are investigated to reduce costs of pre-casting and increase quality of housing.

The main objective of this project is designing precast elements in steel fibre reinforced concrete (sfrc) with local available technologies for low-cost housing in Kenya. With use of steel fibre reinforced concrete (instead of reinforced concrete) a reduction of the costs. On base of the experiences and test results a manual for preparation of sfrc precast structures has been written.

In advance the present housing is examined. The most common way to build a house is to make it of mud and wood, these houses have a lifetime of ten years. A relatively new developed alternative is the eco-homes (of Bamburi special products). This type of housing is the only available precast house in Kenya at the moment, but is still rarely used. Based on the advantages and disadvantages of the present housing the design of a new precast system is made.

The design of the houses and the element is based on several boundary conditions and requirements of which the important ones are stated below.

- A house should have a floor area of 45 m<sup>2</sup> and the construction should be made according to Kenyan Standards;
- To provide a feeling of security the walls should have a thickness of at least 200mm;

- The construction of a house should be able to take place without a crane. The erection of the walls should be done by hand by two or three workmen (light elements);
- There should also be room in the design for expansion and upgrading during the life span, therefore the design has to be modular;
- Erection should be as simple as possible this means stability during construction is required.

The design is divided in four phases: selection and design of the wall; design of the element; design of the sfrc mix; testing of pilot elements

#### *Selection and design of wall*

Out of an election of ten alternatives, three are selected, which are:

- Smaller elements with sandwich construction
- Post-plate construction
- Sandwichblocks, 50 x 120 cm

With these three alternatives further analyses is done and the 'post-plate construction' is selected as the best solution for the design and is further developed. For the connection of the column and the element different possibilities are presented, of which the internal column solution is selected.

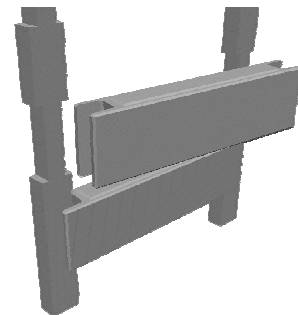

To avoid lifting the elements to the top of the columns and sliding them down from there, some parts of the column are omitted at specified heights. Due to these openings the elements can be placed between the columns by a rotating movement.

#### *Design of the element*

According to the requirement a minimal width of 200 mm is required. To create the required thickness and reduce the weight and use of concrete, the wall-elements must have a hollow or lightweight core. This false thickness is achieved by the use of polystyrene blocks as a core. The dimensions of the final design of the element are 1500 x 200 x 400. This element is light-weight (max. weight of 100 kg), because of the styro foam core inside (1100 x 150 x 360). It is relatively easy to handle and stability during erection is ensured. The loads the construction should be able to withstand are self-weight during production, transport, erection and life span, wind load, impact load and the self-weight of the roof and roof loads.

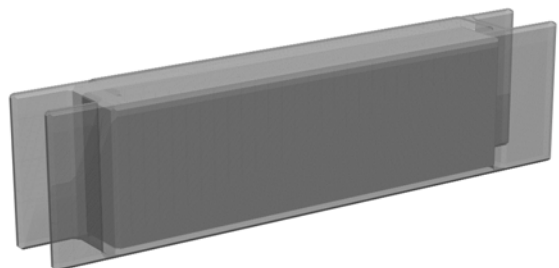



### *Design of the sfrc mix*

For the fabrication of the element a concrete mix has been designed. The main criteria are the compressive strength, the maximum aggregate size and the consistency. The included fibres also require special characteristics of the concrete mix, especially the consistency. Designing a mix always is a process with several iterations steps, depending on many factors.

### *Testing of pilot elements*

To be able to do some testing on the designed elements test elements are constructed. For the production of these test elements a mould had to be manufactured. For this project the mould of steel should be easy to take apart, because of fixation of the styrofoam inside. The disadvantage is labour-intensive assembling.

In total four moulds are manufactured and in two sessions eight test elements could be created. After production of the elements they were weighted and tested on bending, compression, impact (Schmidt hammer test) and wing strength. The results are in conformance with the design calculations.

The estimated costs of one element will be about 560 Ksh (6 Euro). To build a house of 45 m<sup>2</sup> this will be about 83,000 KSh (880 Euro). In this survey the costs of the foundation and the roof are not taken into account. Overall this design will result in a more affordable alternative than the present building methods.





# Table of contents

<b>Group information</b>	<b>iii</b>
<b>Preface</b>	<b>v</b>
<b>Summary</b>	<b>vii</b>
<b>1 Introduction</b>	<b>15</b>
<b>2 General information</b>	<b>17</b>
2.1 Kenya	17
2.1.1 History	17
2.1.2 The country	20
2.1.3 Eldoret	20
2.2 Participating parties	21
2.2.1 Moi University	21
2.2.2 TU Delft	21
2.2.3 MHO-WRE program (cooperation between TU Delft and MU)	22
2.2.4 CICAT	22
<b>3 Problem analysis</b>	<b>23</b>
3.1 Problem description	23
3.2 Project definition	23
3.3 Project objective	23
3.4 Requirements and boundary conditions	24
3.4.1 Functional requirements	24
3.4.2 Structural boundary conditions	24
3.5 Housing situation in Kenya.	25
3.5.1 Introduction	25
3.5.2 Current situation	25
3.5.3 Visit: Rural House, near Kisumu	26
3.5.4 Visit: Ecohomes	26
3.5.5 Visit: Low-cost house near Nairobi	27
<b>4 Alternatives for precast housing</b>	<b>29</b>
4.1 Preliminary designs for precast elements	29
4.1.1 Clamped vertical elements	29
4.1.2 Horizontal elements	30
4.1.3 Zero +: smaller elements	30
4.1.4 Smaller elements with sandwich	30
4.1.5 Combination of corner (half) and wall elements	31

4.1.6	Post-plate construction	31
4.1.7	L-shape construction	31
4.1.8	Sandwich blocks 80x80 cm <sup>2</sup>	32
4.1.9	Sandwich blocks 50x120 cm <sup>2</sup>	32
4.1.10	Hollow blocks	32
4.2	Choice of final alternative	33
4.2.1	Selection of alternatives	33
4.2.2	Multi Criteria Analyses	34
<b>5</b>	<b>Preliminary design element</b>	<b>37</b>
5.1	Connection element-column	37
5.1.1	Envelop column	37
5.1.2	Internal column	38
5.1.3	Plus-shaped column	38
5.1.4	Diamond-shaped column	38
5.1.5	Connection choice	39
5.2	Global dimensions of elements	39
5.2.1	Tolerances	39
<b>6</b>	<b>The technique of sfrc</b>	<b>41</b>
6.1	Introduction	41
6.2	Positive effects on material behaviour	41
6.3	Mechanical properties	42
6.4	Mix design and fibres	43
<b>7</b>	<b>Final design element</b>	<b>45</b>
7.1	Mix design	45
7.2	Loads	45
7.2.1	Self-weight	46
7.2.2	Wind load	46
7.2.3	Impact load	47
7.2.4	Torsion	47
7.3	Design strength	48
7.3.1	Material properties	48
7.3.2	Moment capacity of the element	49
7.3.3	Shear capacity of the element	49
7.3.4	Moment capacity of the column	50
7.3.5	Shear force capacity of the column	51
7.4	Tests	52
7.4.1	general	52
7.4.2	Cube crushing	52
7.4.3	Compression on the element	52
7.4.4	Bending element	53
7.4.5	Bending wing element	53
7.4.6	Schmidt hammer test	54
<b>8</b>	<b>Production of precast sfrc-elements</b>	<b>55</b>

8.1	Mould design	55
8.1.1	Considerations for the mould design	55
8.1.2	Mould design of façade element	56
8.1.3	Mould design for the Columns	59
8.1.4	Manufacturing of the mould	60
8.2	Assembling, casting and demoulding	62
8.2.1	Mould assembly	62
8.2.2	Casting	62
8.2.3	demoulding	63
<b>9</b>	<b>Construction of the building</b>	<b>65</b>
9.1	Foundation and columns	65
9.2	Installation of the elements	66
9.3	Roof structure	67
9.4	Costs	67
9.4.1	Existing alternatives	67
9.4.2	Estimation of costs for SpriT-homes	67
9.5	Comparison concrete Eco-Homes and new design	68
9.5.1	Calculation concrete Eco-Homes	68
9.5.2	Calculation concrete new design	68
<b>10</b>	<b>Conclusion &amp; recommendations</b>	<b>71</b>
10.1	Conclusions	71
10.1.1	Mix design	71
10.1.2	Element design	72
10.2	Recommendations	73
	<b>Literature</b>	<b>75</b>
	<b>Appendices</b>	
	Appendix 1 - Project evaluation	
	Appendix 2 – Sfric manual	
	Appendix 3 – Installation manual	
	Appendix 4 – Advantages and disadvantages	
	Appendix 5 – Report visit Nairobi	
	Appendix 6 – Test results	
	Appendix 7 – Drawings	
	Appendix 8 - Design of the foundation	
	Appendix 9 – Dramix guidelines	
	Appendix 10 – Data Bamburi and Somers	
	Appendix 11 – Finance	



# 1 Introduction

Housing in Kenya presents a problem due to a growing population and urbanisation. The government wants to address this problem and therefore aims to create 150,000 new houses annually. If the costs of a house are as low as possible the house will be available to be built by a group as large as possible. A new quick and cheap building method would assist the government, achieving their goal.

With precast technology it is possible to have a high production under controlled circumstances. The building time can be reduced due to the fact that actions on site are minimised in precast building.

To reduce cost of pre-casting new available techniques are investigated. In this survey steel fibres are added to the concrete instead of reinforcement to try and reduce the total steel and concrete consumption. This reduction of materials can lead to a reduction in total costs.

The objective of the project is to design precast elements with steel fibre reinforced concrete (sfrc) for low-cost housing in Kenya according to local available technologies. Pilot elements will be produced to test whether the design can be realised in practice. On base of these results, a manual for preparation of sfrc precast structures will be written. The design is based on several conditions. The main boundary conditions and requirements are stated below.

A house should have a floor area of 45 m<sup>2</sup> and the construction should be made according to Kenyan Standards. To provide a feeling of security the walls should have a thickness of at least 200mm. The construction of a house should be able to take place without the help of a crane. This means each part of the building should be

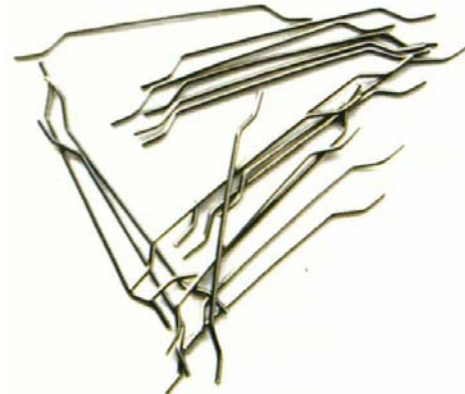

1 | Used steel fibre: Dramix

light enough to be carried by hand with two or three people. There should also be room in the design for expansion and upgrading during the life span, therefore the design has to be modular. Erection should be as simple as possible, this means stability during construction is required.

The order of the report is as follows. The second chapter will give background information on Kenya and the participating parties. In the third chapter the problem will be analysed and more information will be given about housing in Kenya.

The fourth chapter will describe the several design alternatives and will show, how with help of a multi-criteria analysis, one design is chosen. This design is further developed to a preliminary design in chapter five. In chapter six the technique of steel fibre reinforced concrete will be further explained. On the base of this, in chapter seven the final design is given with the appropriate calculations. Chapter eight will give more details about the design of the foundation.

More details concerning the actual production of the elements are given in chapter nine and the method of construction is given in chapter ten. Finally the conclusions and recommendations are given in chapter eleven.



## 2 General information

This chapter gives some general information for non-Kenyans, about the place and country where this project has been executed: Eldoret, Kenya. If you are interested in the history and country of Kenya and general issues about the city of Eldoret, you can read paragraph 2.1.

Paragraph 2.2 shows some information about parties involved in this project.

### 2.1 Kenya

The project made by this group, is situated at Moi University of Eldoret, Kenya. To learn more about the country and the city, their histories will be discussed shortly in the next four pages.

#### 2.1.1 History

Kenya is supposed to be “the cradle of humanity”. Excavations near the Turkana-lake for example, showed almost all stadiums of human evolution, from prehistoric man to homo sapiens. Some skeletons and stone made tools were over two million years old.

Although humanity started here, the region lived in the Old and Middle Stone Age until 8,000 years before Christ.

Among 2,000 years ago the Iron Age started and lasted until many territories were colonised by foreigners.

#### *IMMIGRANTS*

The present country Kenya is a mixture of many cultures and peoples. Already in the 7<sup>th</sup> century the first non-African ethnic groups entered the Kenyan east coast. This was a direct consequence of the growing trade between East Africa and Arabic states. The number of Islamic Arabs increased strongly during the 8<sup>th</sup> century because of riots in Oman, Iran and Syria and the arising of Islam as a new religion.



2 | Map of Kenya (East Africa)

The autochthonous and alien cultures melted together and were the base for the present Swahili-culture.

The trade between East Africa and the Arabic territories was very well benefited by the new immigrants. The trade wasn't restricted to the near area, because countries like China and the present India and Indonesia were visited also. The result was the arising of many rich city-states. Most of them already have had three centuries of prosperity when the Portuguese finally went ashore at the end of the 15<sup>th</sup> century.

Although the costal area of Kenya more and more was influenced by the Islamic culture, the inlands of Kenya remained pure African. In here the Azani-culture developed. In the Rift-valley (picture 1) many great palaces and even irrigation and sewage systems were built by this civilisation.

### *NEW RULERS*

A new era started when Vasco da Gama, searching for a shortcut to India, went ashore at Malindi. After him many other Portuguese sailed to the new 'discovered' land, which was ruled and plundered by them for almost two centuries.

Economically these new rulers had no positive influence on the area. The Portuguese transferred the trade with the Arabs to Portugal, to sell the cargo in Europe. Today, Fort Jesus, at Mombasa (costal area, see picture 2), in that days the most important Portuguese bastion of East Africa, remembers of this period.

Because of bad supply routes and a revolt by the native population in co-operation with the sultanate of Oman, also occupied by Portuguese forces, Portugal was defeated in this region. However, this still wasn't profitably to the Kenyans, for the Omani Arabs soon also ruled with an iron fist. Again some revolts occurred, this time without any positive effect.

In the beginning the trade, now ruled by Oman, mainly concerned ivory. In the 19<sup>th</sup> century however the slave trade dominated more and more. From Zanzibar, then the capital, millions of slaves from the present Kenya and Uganda were shipped to the United States, Brazil and the Caribbean region.

### *EXPLORERS AND COLONIZATION*

At the same time the 19<sup>th</sup> century was very uneventful in the Kenyan inlands. Contacts were only made by different African tribes, living nomadically or by farming. This situation changed when British and German explorers 'discovered' the unknown territories in so-called black Africa, in the late 19<sup>th</sup> century. Many missionaries and commercial enterprises followed their footsteps and concluded many contracts with local tribal chiefs. These contracts later were the base for the territorial claims by the Germans, colonising Helgoland and the present Tanzania, and the British, who 'took care' of the island of Zanzibar and the present Kenya and Uganda.

The British built some railroad tracks to transport goods to and from the farmlands in the fertile Great Rift-valley.

The First World War also hit this area hard, because Great Britain (Kenya) and Germany (Tanzania) charred a border in here. Not only British, but also African recruits fought the German enemy, led by Von Lettow-Vorbeck, who showed them by constantly moving and fighting a guerrilla-war, half the eastern continent, for years.

After the war Kenya officially became a British colony in 1920. The goal of the motherland was to make a 'white Kenya'. In 1923 however, the government decided that Kenya was an African country and the African interests also were more important. Anyway, this was the theory; the true situation still was different for a very long time.

### *INDEPENDENCE*

The fact that the situation of the African population did not improve, was now first answered by a political protest. The organisation however, was forbidden and the leaders were arrested.

The call for independence remained and all over the country anti-colonial groups were founded. After the British recruited new African soldiers to fight in World War II, the groups also could use military protest. This resulted in the Mau-Mau-revolt, a guerrilla against the colonial government. After striking down the revolt (10,000 Kenyan and 95 European casualties), the leaders were arrested and the remaining protest only was desperate.

Only in 1956 the British were willing to negotiate with the Africans and solve the situation politically. The African part in the parliament was increased by eight persons; one of them was Daniël arap Moi.

A route to independence was opened when the government suspended the state of emergency in 1960, proclaimed in 1952 during the Mau-Mau-revolt. Now the power slowly was transferred from the colonial to the Kenyan government. Until, at December the 12<sup>th</sup> in 1963, Kenya was fully independent. The first president was Jomo Kenyatta, who led the independence-groups from the beginning.

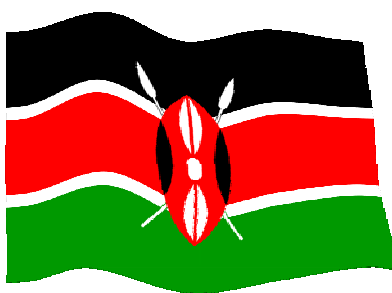

3 | The national flag of Kenya

The country was now led by its own population, what made them start Africanising the region by giving some land back to African people.

The population always consisted of many different tribes. This fact was now remembered and started a civil war in 1964 in the north-east of Kenya by some Somali, who demanded independence. An other struggle, between Luo and Kikoujou, started in 1969, the reason was the murder of a Luo-politician by a Kikoujou.

Kenyatta died in 1978. His successor was Moi, who remained in office until 2002. This period wasn't peaceful either. The national army intervened when riots, caused by famine, took place. In 1982 the air force, supported by students of Nairobi's university, tried to strangle the government.

Real democracy is still difficult in Kenya. Since 1993 the country has a multi-party system, but still there are several accusations concerning desecrating of human rights.

Still, Kenya is one of few countries in the region that has been relatively quiet for many years now. There also are no racial problems, like for example in South Africa or Zimbabwe. The state's device is *harambee* (co-operation), not without a reason.

### 2.1.2 The country

The Kenyan landscape is dominated by the results of an event that happened about four million years ago. The African continent threatened to crack; the Great Rift Valley was shaped. This made the rain forest retreat and all from the valley to the Indian Ocean, a huge steppe appeared. An ideal climate for elephants, lion's etcetera, today the main tourist attraction in Kenya.



4 | Lion in the Masaai Mara National Reserve

Kenya in some numbers:

Population:	30,765,900 (estimation 2001)
Pop. growth:	2,8 % per year
Area:	583,000 km <sup>2</sup>
Independence:	December 12 <sup>th</sup> 1963
Capitol:	Nairobi

### 2.1.3 Eldoret

The town of Eldoret first started as an isolated post-office for surrounding farms in 1910. The name was '64'. The settlement in the Uasian Gishu District was possible because of a new railroad nearby. When the governor decided to establish an administrative centre, the name changed to Eldoret (the Masai word *eldore* means "stony river").

This caused an enormous increase in trade within the prospective city. A bank and several shops were built and the railroad was extended to Eldoret in 1924. Eventually an electricity plant was built in 1933 to light up the main streets and buildings. Already before, the city got a small airport and low-rental housing was erected.

Before the country's independence the local economy was mainly supported by the farmers around the town. Afterwards also many factories were built. Nowadays, agriculture, production, commerce and tourism jointly spell prosperity for the population.

Since 1985 a university is established in the city, named after the former president Daniël arap Moi.

The city has a population of about 246,000 people and is situated at a height of 2100 m above main sea level.

## 2.2 Participating parties

### 2.2.1 Moi University



5 | Moi University administration building Main Campus

Moi University (MU) is located in the Western part of Kenya. In the beginning of the 1980s the Kenyan government recognized that there was a need for a second, technologically oriented university. It was felt that the country needed an academic institute specifically focusing on problems of rural development in its training and research programs. The university was founded in 1985 with the explicit

mission to provide applied programs, and to produce graduates 'who are practical, well informed, efficient and self reliant, capable of functioning in and contributing effectively to development efforts in rural and urban situations' (MU Development Plan, 1994). As a result of this mission the degree programs at Moi University have a practical content in the form of for example field trips, field attachments, and workshop practice.

The university has approximately 10,000 students and 3,000 staff members and several campuses with different faculties.

### 2.2.2 TU Delft



6 | TU Delft's main library

Established on January 8<sup>th</sup> 1842 by King Willem II, TU Delft (*Technische Universiteit Delft*, Delft University of Technology) has a rich tradition of more than 160 years. Initially, the university mainly focussed on civil engineering, but over the years more and more engineering disciplines were added to the academic program. Today, TU Delft has eight faculties collectively offering seventeen Bachelor and more than twenty Master programmes. With

approximately 13,000 students and 2,100 scientists (including 200 professors) TU Delft is the largest and most comprehensive university of engineering sciences in the Netherlands.

The sub faculty of Civil Engineering has about 600 students.

### **2.2.3 MHO-WRE program (cooperation between TU Delft and MU)**

Most of the projects are currently financed by the MHO programme (co-financing programme for Higher Education), which is administered and coordinated by the NUFFIC and financed by the Dutch Minister of Development Cooperation.

### **2.2.4 CICAT**

CICAT is the central liaison office of the Delft University of Technology (TU Delft) providing its faculties and departments with management support in the field of development cooperation activities. The activities implicate long lasting cooperation projects with universities and research organizations in Africa, Asia and Latin-America and to some extent in Eastern Europe.

# 3 Problem analysis

A problem analysis is necessary to give a proper definition to the problem. This will be done in paragraph 3.1. Another important paragraph is number 3.4. In that part the requirements and boundary conditions are subscribed. Finally paragraph 3.5 will give information about the current housing situation in Kenya.

## 3.1 Problem description

To increase the quality of residential housing and increase the amount of houses build the next years in Kenya, the possibility of using steel fibre reinforced concrete for precast (sfrc) elements will be investigated. The inclusion of steel fibres in concrete reduces the fabrication time. The steel fibres in concrete can exclude problems associated with fabrication and placement of conventional steel bars and mesh. The knowledge obtained by this study can be used for other applications of precast elements, for example grain storage facilities and the protection of shallow water wells.

## 3.2 Project definition

Designing precast elements in steel fibre reinforced concrete (sfrc) with local available technologies for low-cost housing in Kenya. On base of these results a manual for preparation of sfrc precast structures will be written.

## 3.3 Project objective

The quality of housing in Kenya is low, especially in rural area it is unsatisfying low. The objective of the population is to own a house. The project objective is to design an alternative for the present way of building that is significant cheaper than the present housing. After the design some pilot elements will be produced and tested.

## 3.4 Requirements and boundary conditions

### 3.4.1 Functional requirements

#### *BUILDING*

- A floor area of 45 square metres;
- For the internal division of space, typical local ground plans are used;
- The walls should carry typical corrugated steel sheets on timber trusses;
- The lifespan should be at least 25 years;
- The functional design should be made according to the Kenyan standards and British standards;
- It should be possible to build a school with use of the elements;
- Only one level should be build with elements;
- Insulation of the houses is not necessary;
- No water should be able to penetrate through the walls;
- The walls have a minimal thickness of 200 mm, to ensure a feeling of safety;
- The building system should be modular;
- It must be possible to extend the house afterwards.

#### *BUILDING METHOD*

- The construction should take place without a crane, elements are handled by hand;
- The building period should be as short as possible (less than 21 days);
- The elements for the construction must be fabricated by local contractors;
- Unskilled workmen should be able to erect the building;
- The building site should be accessible by a truck.

#### *ELEMENTS*

- The elements should be as light as possible (max. 100 kg);
- The elements should not require plaster finishing on any of its faces;
- The elements should be light to reduce transportation costs;
- The elements should be fabricated at low cost;

### 3.4.2 Structural boundary conditions

The structural boundary conditions are mainly in reference to the elements of the house.

#### *GENERAL*

- The design methods will be based on the Euro Codes and British Standards;
- The design will be based on local experience with building engineering;
- For the design the foundation of the house will be straight and casted in situ;
- A measurement to attach the timber trusses to the wall can be taken into account;



- The construction should be made with the minimum use of steel and timber;
- The design of the roof construction should be flexible;
- Avoid a ring beam.

#### *CONCRETE*

- Local available materials will be used (concrete, aggregates, sand, cement);
- The formwork for the concrete foundation is made on site.

#### *ELEMENTS*

- The elements should be able to carry the loads during fabrication, transportation, erection and normal utilisation;
- For the connections mortar may be used;
- The corners should be chamfered;
- The elements should be designed with steel fibre reinforcement;
- The details should be designed as simple as possible;
- The demoulding process must be as simple as possible;
- The fabrication of elements should be capital extensive and labour intensive;
- Tolerances should be provided for erecting.

### **3.5 Housing situation in Kenya.**

To be able to provide a good design for low-cost housing in Kenya it is vital to analyze the current housing situation. To achieve this, a small survey is done and several houses in Kenya have been visited. After the short summary results from the visits are given. Below a list of attention points is given and the consequences are added for further preliminary design of precast houses.

#### **3.5.1 Introduction**

The government of Kenya is not satisfied with the current housing situation in this country. They aim to develop 150.000 houses annually, which are in line with the standards, given by the United Nations. The development of low-cost precast housing will help the government to achieve this goal.

#### **3.5.2 Current situation**

In the current situation the following building methods are present

- Temporary walling in poles and mud
- Sewn Timber walling
- Burnt clay bricks
- Concrete block walling
- Stone walling

The first alternative, also known as mud houses, is cheap, but the life span of a mud house is only two to three years and therefore this is no durable solution. Also these houses do not conform with the British Standards and are therefore not permitted in urban areas.

Sewn timber walling is a good solution as long as the timber is well preserved. However the cost of timber has become high due to forest preservation measures. Adding this to the cost for good wood preservation makes this a non-economical solution.

The last three options are commonly used to construct comfortable houses, which comply with the laws on housing in urban areas, but there are some disadvantages to these building methods. The high material costs are not the only problem, it also takes a long time to construct.

### **3.5.3 Visit: Rural House, near Kisumu**

Rural housing differs per region in Kenya; every tribe has its own specific way of building. The Luo, a large tribe who live in the Kisumu region, make mud houses with timber strengthening. The surface is finished so that it is smooth. The roof is made with corrugated steel plates on timber trusses. The connection between the roof and the wall is fairly open so that birds and other small animals can pass through. The foundation is made of soil strengthened with cement and sand, in wet periods the foundation absorbs water which makes it expand so that doors will have trouble opening and closing.

Remarks after the visit

- The surface of the walls is important. Damages at the surface can be corrected with plaster.
- Because of the opening between roof and the walls there is airflow through the house, this means that for other parts of the house there is no need to avoid air flows.
- A concrete foundation needs to be made in order to avoid swelling of the foundation in wet periods.

### **3.5.4 Visit: Ecohomes**

A cement company in Nairobi is the first company to fabricate prefab elements for housing. This system is now only available in Nairobi and is named Eco-homes. The walls are constructed out of big panels, which are one story high. There are three types of elements; an element with a hole for a window, an element with a hole for the door and a blind wall element. The minimum weight of an element is 200 kg and the maximum weight is 400 kg. This means the houses need to be constructed with a crane or a very big group of people.

First the foundation is made, on this a steel beam is fixed to guide the elements, which then can be placed. The elements are fixed using a steel ring beam on top. The roof construction is connected to this steel ring-beam. A problem during erection is that the elements are not stable on their own and when placing the first element, the

ring-beam isn't present yet. Erection is therefore started in a corner of the house where one element is held up by hand until the second element is placed perpendicular to this. This corner is then fixed by placing a ring beam on top. Now the rest of the house can be constructed from this stable part. Further information about these Eco-homes can be found in appendix 5.

Remarks after this visit

- Elements should be light to ensure that handling is simple.
- Extra use of steel has to be avoided, because this will result in welding on site and steel is also expensive.
- Building is easier if the construction is stable during building phase.



7 | Erection of an Eco-home

### 3.5.5 Visit: Low-cost house near Nairobi

In the outskirts of Nairobi there is a small contractor working on a pilot project concerning low-cost housing. In this project the principle of pole plate construction is also used. There is no false thickness so the walls are only 50 mm thick and the columns are visible in the façade. The roof is made of sawn wood trusses covered with metal plates. The elements are made on the site itself with simple moulds and mixing equipment. The moulds are made in a way that the surface of the plate elements looks like it is made of separate bricks. Although this isn't a really pretty solution it is a cheap one, which can be expanded or upgraded ones funds are available.

Remarks after this visit

- The post plate construction is a feasible idea.
- The presence of columns in the façade determines the architecture.

The texture of the concrete can easily be adjusted to improve the appearance.



# 4 Alternatives for precast housing

In Kenya already one type of precast housing exists, the Eco-homes. This Eco-Homes system has some disadvantages; those have to be eliminated with a new design. In the design of the Eco-Homes several steel profiles are used to fix elements. The elements are bolted together with use of those profiles. This connection can be improved by making use of concrete-to-concrete connections.

## 4.1 Preliminary designs for precast elements

In the next chapter several preliminary designs are reflected for local precast housing. The alternatives are based on local examples, which are mentioned in the previous chapter. The construction of the walls is specially examined.

The alternatives are given with the most important advantages and disadvantages. In appendix 4 more advantages and disadvantages are mentioned.

### 4.1.1 Clamped vertical elements

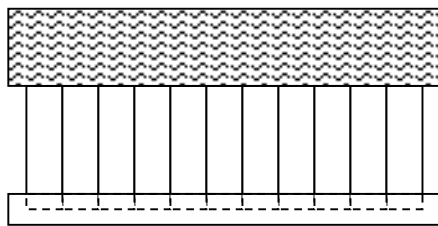

8a | Sideview of clamped vertical elements

8b | cross-section clamped element and ground floor

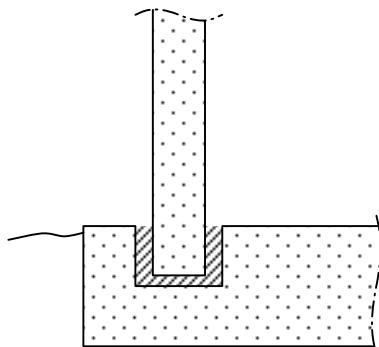

The way to connect elements with each other, or with an already in-situ casted concrete part, is important in designing precast elements.

A way to connect the foundation's ground floor and the wall-elements is given in the figures 8a and 8b next to this. By using a beforehand casted groove in the in-situ floor, you can place the precast elements in, fix it with wedges and pour mortar next to it. The elements can be situated in a perfect vertical way by hammering some wooden blocks between the edge of the foundation and the precast element. To make sure that mortar is surrounding the elements all over, there also has to be a little block below the element. The mortar can now flow along.

The size of the elements is depending on the maximum allowed dead weight.

### ADVANTAGES AND DISADVANTAGES

- ✓ no concrete ring beam or steel profiles are needed;
- ✓ the steel profile on the floor can be skipped;
- ✗ the floor has to be designed for clamping;
- ✗ the elements have to be designed for clamping.

#### 4.1.2 Horizontal elements

Instead of using vertical elements, horizontal elements can be applied. By making grooves and notches on these building stones, they can be stacked up together and, when filled with mortar, withstand a mutual shear force. (see figure 9a and 9b)

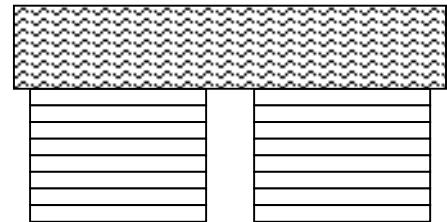

9a | stacking elements

9b | connection between elements

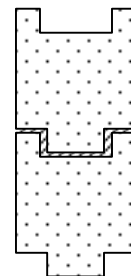

### ADVANTAGES AND DISADVANTAGES

- ✓ weight of a single element can be reduced by decreasing its length;
- ✓ easy building;
- ✗ difficult connections in corners on both sides;
- ✗ long erection time, because of curing time (mortar between).

#### 4.1.3 Zero +: smaller elements

To improve the erection of an Eco-Home, you can reduce the weight of the elements. This can be done by reducing their width (parallel to the façade).

### ADVANTAGES AND DISADVANTAGES

- ✓ experienced techniques;
- ✓ lighter elements;
- ✗ many workmen needed for erecting;
- ✗ small elements.

#### 4.1.4 Smaller elements with sandwich

To improve the "external" look of the building the walls have to be thickened. Without using more concrete this can be done by placing a space or lightweight material within. The result is a type of sandwich element.

### ADVANTAGES AND DISADVANTAGES

- ✓ lighter elements;
- ✓ false thickness;
- ✗ ring beam and floor profiles needed;
- ✗ unevenness near windows possible.

#### 4.1.5 Combination of corner (half) and wall elements

This alternative uses a stable section of its own, now stable corner sections will be used. To reduce the weight of these L-shaped sections they are only half the height of the wall elements. Next to the corner sections plain wall elements are placed.

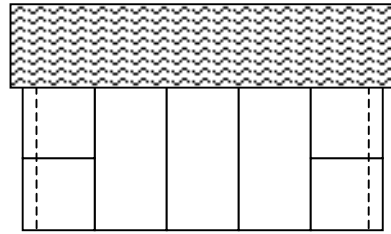

10a | Side view of L-shaped section on corners

#### ADVANTAGES AND DISADVANTAGES

- ✓ stiff corner connections;
- ✓ stable construction;
- ✗ difficult moulds;
- ✗ difficult to carry by hand.

10b | Cross section (hor. plane) elements

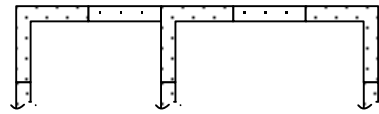

#### 4.1.6 Post-plate construction

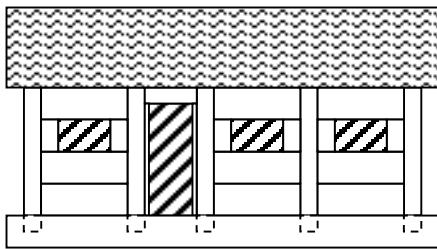

11a | Poles and plates form façade

11b | Connection between elements

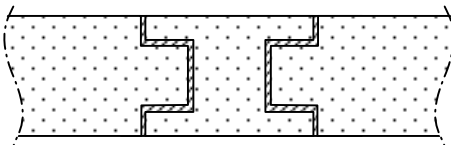

Just like the first alternative, this version also contains elements that are clamped in the foundation floor. Instead of whole elements, now only the poles are to be fixed. Between these columns plates can be stacked to make a real wall. Within the plates holes can be introduced to shape windows.

#### ADVANTAGES AND DISADVANTAGES

- ✓ modular building possible;
- ✓ flexible width of elements;
- ✗ no correction afterwards;
- ✗ association with fence-construction.

#### 4.1.7 L-shape construction

To start with a stable section during erection, an L-shaped element will be placed on the foundation floor. On top of this element other straight elements can be put. Afterwards a new layer of concrete has to be poured on the foundation floor, to avoid a threshold.

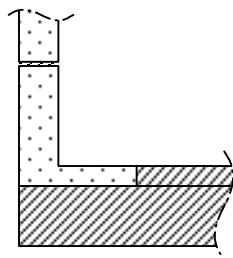

12 | Cross section of L-shaped section on floor

#### ADVANTAGES AND DISADVANTAGES

- ✓ stable constructions;
- ✗ difficulties during casting floor;
- ✗ possibilities to fit necessary.

#### 4.1.8 Sandwich blocks 80x80 cm<sup>2</sup>

Instead of vertical or horizontal elements the possibility to use square or rectangular blocks in a certain distribution also exists. This way of erecting can be compared with simple large bricks. The difference however is the reduction of its weight. To achieve a permitted weight the blocks are made with a sandwich construction too.

##### *ADVANTAGES AND DISADVANTAGES*

- ✓ easy size of blocks;
- ✓ modular building;
- ✗ unevenness near windows and doors;
- ✗ stability during erection can be a problem.

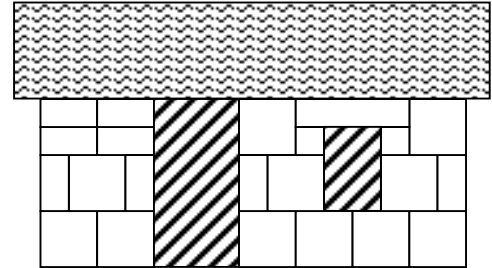

#### 4.1.9 Sandwich blocks 50x120 cm<sup>2</sup>

13 | Sandwich blocks arranged

A variant on the previous idea is to use a different size of sandwich blocks.

##### *ADVANTAGES AND DISADVANTAGES*

- ✓ easy blocks;
- ✓ modular building;
- ✗ stability;
- ✗ problem at windows.

#### 4.1.10 Hollow blocks

Instead of using massive concrete or dried clay stones, also hollow blocks can be used. This decreases the use of concrete considerably.

##### *ADVANTAGES AND DISADVANTAGES*

- ✓ false thickness;
- ✓ easy to transport;
- ✗ difficult to manufacture;
- ✗ mortar necessary.



## 4.2 Choice of final alternative

In this paragraph a final choice will be made out of the different alternatives of paragraph 4.1.

### 4.2.1 Selection of alternatives

On the basis of the advantages and disadvantages of the different alternatives a deliberation can be made. For the general overview all alternatives are given in the table below.

Alternatives	
1	Clamped vertical elements
2	Horizontal elements (lego)
3	Zero +, smaller elements
4	Smaller elements with sandwich construction
5	Combination of corner elements (half) and panels
6	post-plate construction
7	L-shape construction
8	Sandwichblocks, 80 x 80 cm
9	Sandwichblocks, 50 x 120 cm
10	Hollow blocks

table 1 | Overview of alternatives

Out of the advantages and disadvantages (see appendix 4) three alternatives are selected which are the most realistic solutions.

The selected alternatives are:

- Alt. 4 zero ++, smaller elements with sandwich construction
- Alt. 6 post-plate construction
- Alt. 9 sandwichblocks, 50 x 120 cm

With this three alternatives a further analyses will be made.

#### 4.2.2 Multi Criteria Analyses

With the three selected alternatives of previous paragraph a multi criteria analyses is made with use of the permutation method. The alternatives are characterised by the following qualitative evaluation matrix. Each alternative is judged at several criteria. The main criteria (e.g. C1) are the result of its sub criteria together.

Judgement: 1 = third rank  
 2 = second rank  
 3 = first rank (best score)

Alternatives		4	6	9
		zero ++, smaller elements + sandwich construction	post-plate construction	sandwichblocks, 50 x 120 cm
Criteria				
<b>C1 production process</b>		1	2	3
	simple design (simplicity of the moulds)	3	2	1
	nr of different types of elements	2	1	3
	bunt corners	1	2	3
	production by local contractors	1	3	2
<b>C2 building process (on site)</b>		1	3	2
	stability during construction	2	3	1
	fragility during transportation and erection	1	2	3
	plastering not necessary	3	2	1
	additional materials (use of e.g. steel profile and mortal)	1	3	2
	tolerances	1	2	3
	use of crane	1	2	3
<b>C3 construction time</b>		3	2	1
	manufacture time	2	3	1
	erection time	3	2	1
	organisation time (instructions for workmen)	3	2	1
<b>C4 flexibility</b>		1	3	2
	connections	1	3	2
	modular building	1	2	3
	house design	1	3	2
<b>C5 total costs</b>		2	3	1
	manufacture costs	2	3	1
	labour costs	3	2	1
	transport costs	1	2	3
<b>C6 weight of elements</b>		1	3	2
<b>C7 lifespan (25 years)</b>		3	2	1

table 2 | Criteria evaluation matrix

The importance attached to the different criteria (C1-C7) is expressed in weights. The weight factors given to the criteria, together with the evaluation matrix, are given in the table below. In this overview the alternatives are represented as A1,A2 and A3:

- A1 - zero ++, smaller elements with sandwich construction (Alt. 4)
- A2 - post-plate construction (Alt. 6)
- A3 - sandwichblocks, 50 x 120 cm (Alt. 9)

	A1	A2	A3	weights 1	weights 2
<b>C1 production process</b>	1	2	3	0,15	0,20
<b>C2 building process (on site)</b>	1	3	2	0,15	0,20
<b>C3 construction time</b>	3	2	1	0,10	0,10
<b>C4 flexibiliy</b>	1	3	2	0,10	0,05
<b>C5 total costs</b>	2	3	1	0,25	0,20
<b>C6 weight of elements</b>	1	3	2	0,20	0,20
<b>C7 lifespan (25 years)</b>	3	2	1	0,05	0,05
				1,00	1,00

table 3 | Weight factors

Because of the fact that the total costs (C5) and weight of elements (C6) are marked as important they are given a higher importance in relation with the other criteria (at the first weight set). In de second weight set the production (C1) and building (C2) process are founded slightly more important then in the first weight set. The total costs and the flexibility (C4) in this case are given less weight.

Now the best way to arrange the alternatives will be examined. A problem with 3 alternatives gives  $3! = 6$  possibilities to arrange the alternatives.

- Possibility 1 (R1) : 1 > 2 > 3  
 Possibility 2 (R2) : 1 > 3 > 2  
 Possibility 3 (R3) : 2 > 1 > 3  
 Possibility 4 (R4) : 2 > 3 > 1  
 Possibility 5 (R5) : 3 > 1 > 2  
 Possibility 6 (R6) : 3 > 2 > 1

e.g. R1 with respect to criteria 1 (see C1 in table on the next page):

$$\begin{aligned}
 A1 > A2 &\rightarrow -1 \\
 A2 > A3 &\rightarrow -1 \\
 A1 > A3 &\rightarrow \underline{-1} + \\
 &\quad -3
 \end{aligned}$$

The resulting matrix is:

	C1	C2	C3	C4	C5	C6	C7	Total weigth1	Total weight 2
R1 : 1>2>3	-3	-1	3	-1	1	-1	3	-0,2	-0,45
R2 : 1>3>2	-1	-3	1	-3	-1	-3	1	-1,6	-1,35
R3 : 2>1>3	-1	1	1	1	3	1	1	1,2	0,85
R4 : 2>3>1	1	3	-1	3	1	3	-1	1,6	1,35
R5 : 3>1>2	1	-1	-1	-1	-3	-1	-1	-1,2	-0,85
R6 : 3>2>1	3	1	-3	1	-1	1	-3	0,2	0,45
weights 1	0,15	0,15	0,1	0,1	0,25	0,2	0,05	1,6	
weights 2	0,20	0,10	0,05	0,20	0,20	0,05	0,05		1,35

table 4 | Ranking

The values of the criteria are multiplied with the weight factors resulting in a final score of possibilities to arrange. Out of above table one can conclude that the best alternative ranking is 2, 3, 1. This means that the post-plate construction is the best solution for the housing element design.

# 5 Preliminary design element

In chapter 3 the requirements and boundaries for the different elements are written down. The main requirements are the simplicity and the weight. The maximum weight is about 100 kg.

## 5.1 Connection element-column

For the connection between the column and the element two kind of connections can be applied. Below the different alternatives are noted, including their advantages and disadvantages. For each alternative different drawings are given: for the corners and the parallel connection. On basis of the advantages and disadvantages a connection is chosen.

### 5.1.1 Envelop column

The elements and the column are connected with a ridge on the element. This ridge slides between two protrusions of the H-shaped column. The element itself can be hollow, or contain a light internal material.

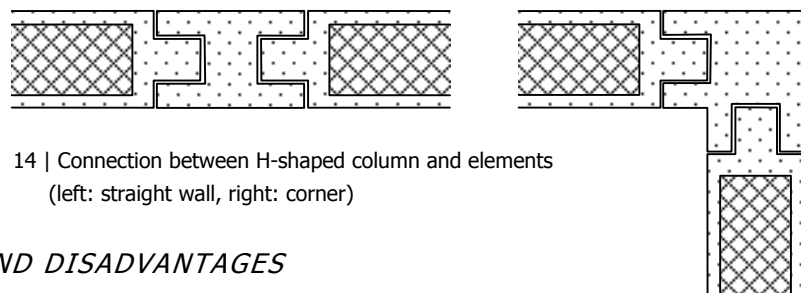

14 | Connection between H-shaped column and elements  
(left: straight wall, right: corner)

#### *ADVANTAGES AND DISADVANTAGES*

- ✓ most material of column on outside (moment-capacity);
- ✓ relatively easy elements;
- ✗ many concrete needed to make a connection;
- ✗ two grooves on the outside near the column.

### 5.1.2 Internal column

The connection between the column and the elements can also be the other way round. This means that the protrusions now will be situated on the elements and the columns have a ridge, or even are the ridge by themselves (this paragraph).

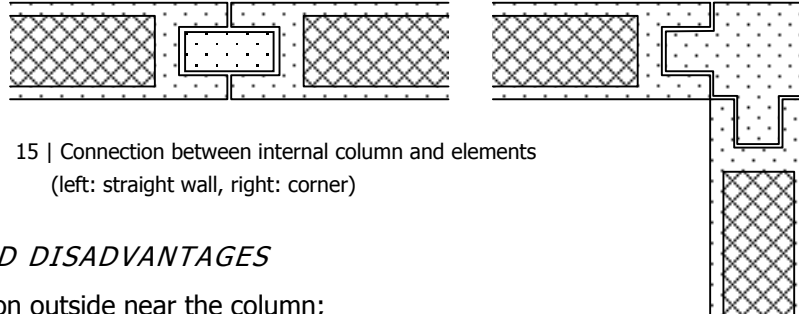

15 | Connection between internal column and elements  
(left: straight wall, right: corner)

#### *ADVANTAGES AND DISADVANTAGES*

- ✓ one groove on outside near the column;
- ✓ less concrete needed for connection;
- ✗ concrete-material of column in centre (inconsequent);
- ✗ fragile elements (protrusions).

### 5.1.3 Plus-shaped column

Another variant of the last alternative is the one with a plus-shaped column, instead of a rectangular one. This means that more concrete is needed to fabricate these columns.

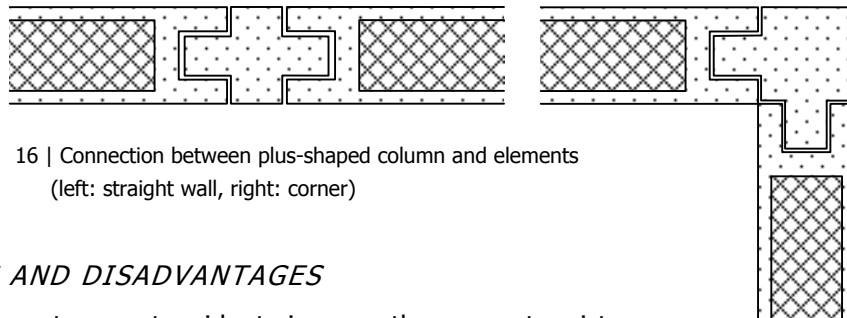

16 | Connection between plus-shaped column and elements  
(left: straight wall, right: corner)

#### *ADVANTAGES AND DISADVANTAGES*

- ✓ some concrete on outer side, to improve the moment-resistance;
- ✓ easy and robust column;
- ✗ many concrete needed to fabricate the column;
- ✗ fragile columns (protrusions).

### 5.1.4 Diamond-shaped column

Instead of a parallel column (with only one groove), it can also be rotated. This can, for example, be obtained by a diagonal square column. Just like the figure shows.

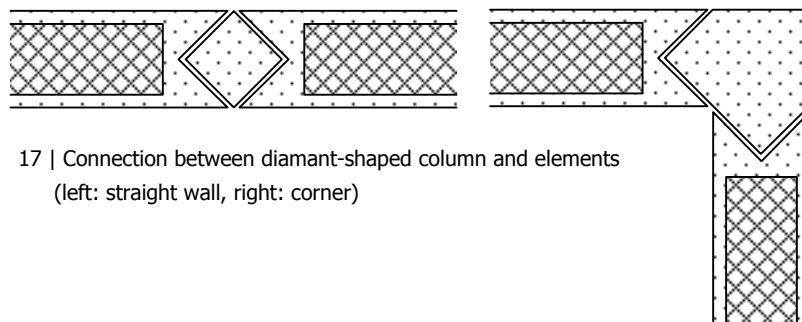

17 | Connection between diamant-shaped column and elements  
(left: straight wall, right: corner)

## ADVANTAGES AND DISADVANTAGES

- ✓ simple mould for elements, perpendicular corners;
- ✓ simple shaped and robust column;
- ✗ sensitive to tolerances, because of wrong angle of column;
- ✗ difficulties with finishing of groove.

### 5.1.5 Connection choice

Out of the four different alternatives for the connections, the internal column has been chosen. The choice is based on the required aesthetic for the total picture.

## 5.2 Global dimensions of elements

To ensure a feeling of safety for future owners, the walls should have a minimal width of 200 mm (requirement). This boundary condition is the most important one in determining the dimensions of the elements and columns. For structural purposes a thickness of 50 mm should be sufficient (Bamburi Eco-homes).



18 | Mould designed to make the element

To create the required thickness and reduce the weight and use of concrete, the wall-elements must have a hollow or light-weight core (e.g. polystyrene). This can be achieved by the use of polystyrene blocks inside, or by the use of a mould which leaves one side of the element opened to create an open space.

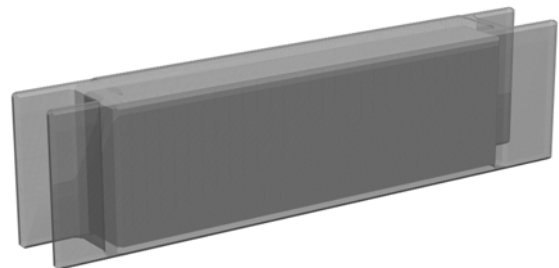

19 | Element with styrofoam block inside

Both solutions have got some pro's and con's. To ensure the hollow space in an element (last solution) the mould will be complicated. Mould design requires that the internal angles of the element can not be perpendicular. This means a larger quantity of concrete is needed to produce an element. The biggest disadvantage of the other solution is the introduction of another material to the building site (polystyrene).

### 5.2.1 Tolerances

During construction a lot of small failures can be made. To make sure this does not influence the positioning of the elements, some tolerances are determined.

Possible fault in the construction:

- Position of the columns: 3 cm (parallel to the wall) and 1 cm (perpendicular to the wall);
- Initial angle between column and floor: 1 % of 2,4 meter = 2,4 cm (parallel);
- Rotation of the column section in horizontal plane: 2 degrees: 0,4 cm (perpendicular) and 0,2 cm (parallel);

Needed tolerances:

A:  $3 \text{ cm} + 2,4 \text{ cm} + 0,2 \text{ cm} = 5,8 \text{ cm}$

B:  $1 \text{ cm} + 0,4 \text{ cm} = 1,4 \text{ cm}$

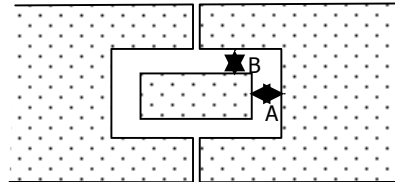

20 | Tolerances near the column

Increasing of the tolerances also means the dimensions of the columns decrease. In this calculation the outer width of the total wall is 200 mm, the width of the wings is already known too, so the column is the one to get smaller. However this is not a real problem. The horizontal forces acting on the column are only very small. That small that even a tiny column, interacting with the covering elements, can withstand those forces. The main function of the columns is to be a guiding tool during the positioning of the elements.



# 6 The technique of sfrc

## 6.1 Introduction

Concrete has different mechanical properties in tension and compression. It is a good material to withstand compression forces, but not tension forces. The tensile strength is only one tenth of the compression strength. Exposure to tensile forces will lead to brittle failure. Adding fibres will improve this lack in tensile strength and ductility.

Fibres of any sort can be added as long as they are able to withstand the alkaline environment, don't have a negative effect on the compression strength of concrete and have good behaviour regarding to the tensile strength. Examples of fibres are glass fibres, carbon fibres, cellulose fibres and steel fibres. In this study steel fibres are used, which are generally less expensive than the other types.

## 6.2 Positive effects on material behaviour

Besides having a positive effect on the ductility and the crack width, there are some other reasons to use steel fibres to reinforced concrete. Steel fibres don't need a concrete cover like ordinary steel bars, therefore with fibre reinforcement very slender constructions are possible. While casting the use of fibres reduces the number of steps that have to be taken due to the fact that the placement of steel bars isn't necessary.

There are several types of steel fibres, depending on their shape and production technique they can be classified with some specific characteristics. There are steel wire fibres, pre-stressed fibres and tin fibres. The first type is made out of cold drawn steel wire, it can be galvanized, a profile can be applied and they can have enlarged- or hooked-ends. The second type, pre-stressed fibres, is made with a rotating device that cuts the fibres of massive steel blocks. The result is a wire, which is smooth on one side and raw on the other side. The last type, tin fibres, is made cutting tin plates. The fibres are reshaped using pressure and this can result in

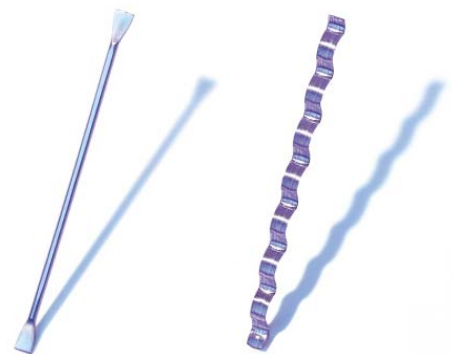

21 | Types of fibres: enlarged ends (left) and pressure shaped tin fibres (right).

bended hooks or surface profiling. Due to the fact of a low quality starting material the fibres also have a relative poor tensile strength.

The properties of the composite material are mainly depending on the method in which the fibres connect with the cement. Bonding has - like with normal reinforcement – a compound part, a friction part and a shape part. Pre-stressed fibres have a really good compound connection due to the overall rawness. The material behaviour is therefore very stiff, but is also brittle. The failure of hooked-end fibres is based on the plastic deformation of the fibre, this results in a more ductile composite.

In this survey steel wire fibres with hooked ends are used (figure beside), these fibres are imported from Belgium and are called Dramix. Novocon provides the fibres that are locally available; they have either tin fibres (Xorex) or fibres with enlarged-ends (Novotex), these fibres will have some different characteristics from the Dramix fibres.

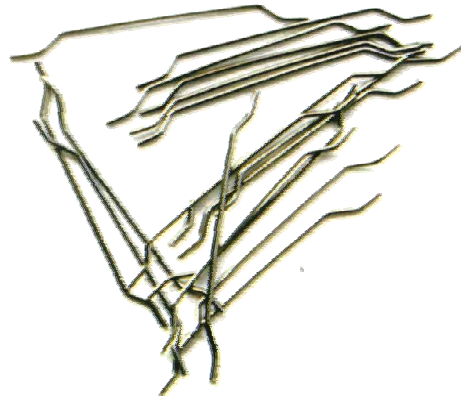

22 | Used steel fibre: Dramix

### 6.3 Mechanical properties

The use of steel of fibre reinforced concrete is less efficient than the use of bar reinforcement. This is partly because the fibres are uniformly distributed in the concrete. A steel bar will be placed there where the tensile forces occur, as apposed to the fibres which are also present in compression zones where they are not useful. With respect to the moment resistance of a beam this uniform contribution also results in a smaller arm to develop a moment over. The orientation of the fibres will also give a small disadvantage due to the fact that only a part of the fibres will be in the direction the tensile forces occur.

The maximum load that the material can withstand depends on the amount of fibres used. If there is a high amount of fibres used ( $120\text{kg/m}^3$ ) the tensile stress can increase after cracking. Due to the inefficient use of steel this is an expensive alternative for steel bar reinforcement.

If a low amount of fibres ( $40\text{ kg/m}^3$ ) is used the tensile force which the structure can withstand, will be lower after cracking as the fibres pull out of the cracked surface. The strain at complete failure is increased and therefore the area under the complete stress strain curve is increased; this means the material is tougher. This increase in toughness results in the fact that plastic hinges can be formed and plastic calculation is possible.

The design for low-cost housing regards one-story buildings; this means the loads are very low. The construction will be able to withstand the loads even though the used steel is not optimally used.

## 6.4 Mix design and fibres

When designing a concrete mix the used fibres and the purpose of the mix should be taken into account. This ensures that both the fresh and the hardened concrete have the intended characteristics. In determining the desired workability it should be considered that fibres reduce the workability of fresh concrete, this effect can be counter balanced by adding plasticisers.

In order to obtain the full design benefit of fibre reinforced concrete, a number of measures have to be taken.

- The fibre length should be equal or greater to two times the maximum aggregate size.
- The maximum amount of fibres that can be used depends on the quantity and size of the aggregates and the L/D (Length/Diameter) ratio of the fibres themselves. Manufactures of fibres give out tables, which display the maximum amount of fibres that can be added to the concrete mix.
- The finer the aggregate grading the easier it is to mix in the fibres.
- Fibre length should be selected to avoid difficulties in placing of concrete, the elements to be casted, have small dimensions.
- A sand content of 40-50% of the weight in aggregates is recommended.
- The fibre should never be added as first component of the mix, they can be either introduced together with the sand and the aggregates or can be added to the freshly mixed concrete.
- The concrete should be placed and compacted in order to ensure no undesired orientation or a lack of fibres in certain zones will occur.



# 7 Final design element

This chapter will result in the final design of the elements. Attention will be given to the detailing of connections between columns and elements, but also to the calculation of the loads. This will result in a mould design.

## 7.1 Mix design

For every structure it is necessary to design a mix according to the requirements. The sfrc element requires a special mix. The main criteria are the compressive strength, the maximum aggregate size and the consistency. For a good strength and workability the grading (see figure 23) of the applied aggregates is important. Designing a mix is always a process with several iterations steps, due to the facts that the mix is dependent of many factors.

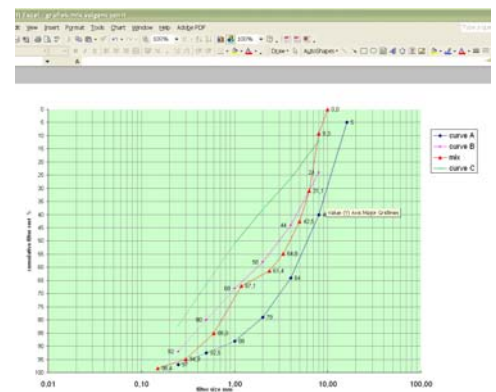

23 | Grading of the concrete mix

In appendices 2 and 6 more details about the process and the mix design are given.

The specifics of the used concrete mix for the sfrc elements are as follows. The amounts are for one element (100 kg).

Coarse aggregate (6-9 mm)	32 kg
Fine aggregate (2-6 mm)	8 kg
Sand	27 kg
Cement	21 kg
Water	10 kg
Fibres	2 kg



24 | Materials for the concrete mix

## 7.2 Loads

There are several loads the construction should be able to withstand: self-weight during production, transport, erection and life span; wind load; impact load and the dead weight of the roof and roof loads. Calculation will be based on the British Standards (BS), Kenyan Standards (KS) and in case these aren't available, Dutch standards and Euro Codes. The assumption is made that if one standard is met, the

construction will have sufficient capacity. At each calculation the used standard is mentioned.

### 7.2.1 Self-weight

The self-weight is mainly introduced by the weight of the concrete.

$$A_c = (25 * 400) * 2 + 25 * 150 = 23750 \text{ mm}^2 / \text{m}$$

$$q_{sw} = A_c * \rho_c = 23750 * 2300 = 54.6 \text{ kg} / \text{m}$$

$$q_{sw} = 546 \text{ N} / \text{m}$$

While being transported the element will be carried by hand, this will result in a dynamic load. Their own length is the span. The dynamic load factor is 2, the maximum moment and the shear force can now be calculated.

$$q_{tot} = \gamma_{dyn} * q_{sw} = 2 * 546 = 1092 \text{ N} / \text{m}$$

$$M_{MAX} = 1/8 * q_{tot} * l^2 = 1/8 * 1092 * 1.5^2 = 307 \text{ Nm}$$

$$V_{MAX} = 1/2 * q_{tot} * l = 1/2 * 1092 * 1.5 = 819 \text{ N}$$

### 7.2.2 Wind load

The wind load on the elements is calculated on a basic air pressure of 0,9 kN/m<sup>2</sup>. In case of pressure you multiply this with a factor of 0,8, in case of suction with a factor of 0,4. The first will result in the highest loads on the wall elements and columns and is therefore used in this calculation. The height of one element is 400 mm. The load factor for variable loads for houses is 1.4(BS).

$$q_w = 0.9 * 0.8 = 0.72 \text{ kN} / \text{m}^2$$

$$q_w = 0.72 * 0.4 = 288 \text{ N} / \text{m}$$

In the element this will lead to the following loads

$$q_{wtot} = 1.4 * 288 = 403 \text{ N} / \text{m}$$

$$M_{MAX} = 1/8 * q_{wtot} * l^2 = 1/8 * 403 * 1.5^2 = 113 \text{ Nm}$$

$$V_{MAX} = 1/2 * q_{wtot} * l = 1/2 * 403 * 1.5 = 302 \text{ N}$$

In the columns this will lead to the following loads

$$q_{wtot} = 0.72 * 1.4 = 1.01 \text{ kN} / \text{m}^2$$

$$q_{wtot} = 1.5 * 1.01 = 1.51 \text{ kN} / \text{m}$$

$$M_{clamp} = 1/2 * q_{wtot} * l^2 = 1/2 * 1.51 * 2.8^2 = 5.92 \text{ kNm}$$

$$V_{MAX} = q_{wtot} * l = 1.51 * 2.8 = 4.3 \text{ kN}$$

### 7.2.3 Impact load

The Impact load will be tested using an impact hammer for roads. This is to determine whether elements will damage easy during their lifespan. In appendix 6 more details about testing of this type of loading will be given.

### 7.2.4 Torsion

The section is u-shaped; therefore if it is loaded in the vertical plane torsion will occur. Loading in the vertical plane will happen when the element is carried with one of the webs up and in case of wind load. In case of that the situation where the element is carried gives a higher load this case is taken into account.

For finding the torsion moment the shear centre and the centre of gravity have to be calculated. Only a part of the section is active and therefore only the active part will be used in this calculation.

$$b_w = 1500 * 0.1 + 25 = 175mm$$

$$A_c = (25 * 150) * 2 + 30 * 200 = 13500mm^2$$

The distance of the side of the plane to the centre of gravity is

$$\frac{2 * 150 * 25 * 105 + 150 * 30 * 15}{13500} = 63.3mm$$

The distance of the shear centre of to the centre of the web can be determent with the following formula if the section acts as a uniform thickness or is close to this.

$$e = b^2 h^2 t / 4I_{zz}$$

$$e = (165^2 * 175^2 * 25) / (4 * 75.9 \cdot 10^6) = 68.7mm$$

$$I_{zz} = \frac{1}{12} * 175 * 200^3 - \frac{1}{12} * 145 * 150^3 = 75.9 \cdot 10^6 mm^4$$

The distance from the shear centre to the centre of gravity is

$$= 68.7 - 15 + 63.3 = 117mm$$

Taking the moments around the shear centre results in the torsion moment. The span for the torsion is smaller due to the fact that only the middle part of the element is u-shaped. The length used for the calculation of the torsion moment is 1125mm.

$$T = 1.125 / 2 * 1092 * 117 = 71867Nmm$$

$$\begin{aligned} \Sigma h_{\min}^3 h_{\max} &= 2 * 25^3 * 150 + 30^3 * 200 \\ &= 2 * 2.34 \cdot 10^6 + 5.4 \cdot 10^6 \\ &= 10.1 \cdot 10^6 mm^4 \end{aligned}$$

The torsion moment can be calculated with the following formula

$$v_t = \frac{2 \cdot T}{h_{\min}^2 (h_{\max} - h_{\min} / 3)}$$

The web absorbs a part of the torsion and the flanges absorb a part.

$$T_{web} = \frac{5.4 \cdot 10^6}{10.1 \cdot 10^6} * 71867 = 38424 Nmm$$

$$v_t = \frac{2 * 38424}{30^2 * (200 - 30 / 3)} = 0.45 N / mm^2$$

$$T_{flange} = \frac{2.34 \cdot 10^6}{10.1 \cdot 10^6} * 71867 = 16650 Nmm$$

$$v_t = \frac{2 * 16650}{25^2 * (150 - 25 / 3)} = 0.38 N / mm^2$$

The total shear force consists of two parts: a torsion part and a normal shear force part. The normal shear force part is

$$v = \frac{819}{30 * 200} = 0.14 N / mm^2$$

Adding these tensions will result in the total shear force

$$v_{total} = 0.45 + 0.14 = 0.59 N / mm^2$$

## 7.3 Design strength

The stress distribution is very specific for steel fibre reinforced concrete. The compressive strength and deformation characteristics are the same as used for reinforced concrete.

### 7.3.1 Material properties

The maximum forces the cross section can withstand, are determined according to values given by Bekeart N.V. (Belgium). They are depending on the kind of fibres, the amount of fibres and the concrete quality.

The used concrete and fibres have the following characteristics.

Used fibres:	-Dramix 45/30 RLBN:
	-length            30 mm
	-diameter        0,62 mm
	-ft                1050 N/mm <sup>2</sup>

Concrete	B25
$f_{ctm,eq.300}$	2,4 N/mm <sup>2</sup>
$f_{ctm,eq.150}$	2,1 N/mm <sup>2</sup>
$T_{fd}$	0,25 N/mm <sup>2</sup>



### 7.3.2 Moment capacity of the element

The calculations are made with the assumption that the concrete is already cracked. After cracking there will be a stress distribution as shown in Dramix Design Guideline (appendix 9, figure 3). The strain in the tension zone is limited to 10 ‰. It is not possible to calculate with this distribution, therefore rectangular stress blocks are presumed (figure 25).

Depending on whether the element is loaded in the vertical or in the horizontal plane it has different characteristics.

Loaded vertical plane (figure 26) it has the following moment capacity.

$$A_{br} = (25 * 300) * 2 = 7500mm^2$$

$$F_{br} = \sigma_{br} * A_{br} = 0.78 * 7500 = 5850N$$

$$M_u = F_{br} * arm = 5850 * 0.2 = 1170Nm$$

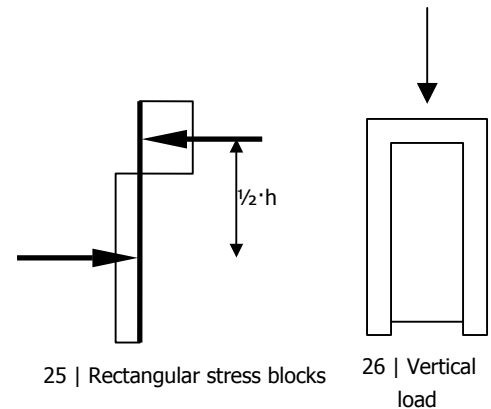

Loaded horizontal plane (figure 27) it has the following moment capacity.

$$b_w = 0.1 * 1500 + 25 = 175mm$$

$$A_{br} = 175 * 25 + (148 - 25) * 25 = 7450mm^2$$

$$F_{br} = \sigma_{br} * A_{br} = 0.78 * 7450 = 5811N$$

$$M_u = F_{br} * arm = 5811 * 0.1 = 581Nm$$

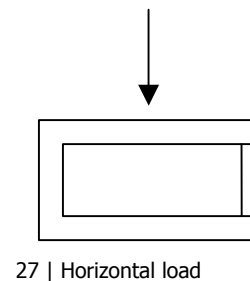

As can be seen in the previous chapter the maximum load is 307 Nm so the capacity exceeds the load ( $M_u > M_d$ ).

### 7.3.3 Shear capacity of the element

The shear strength of a section is given by the following formula.

$$V_{total} = V_{cd} + V_{fd} + V_{wd}$$

$V_{cd}$  The contribution of concrete

$V_{fd}$  The contribution of the fibres

$V_{wd}$  The contribution of the shear reinforcement

The contribution of the concrete ( $V_{cd}$ ) is calculated according to Eurocode 2, because the Dramix guidelines are used.

$$V_{cd} = \{ \tau_{Rd} * k * (1.2 * 40 \rho_1) + 0.15 * \sigma_{cp} \} * b_w * d$$

$$\tau_{Rd} = 0.25 * f_{ctk,ax} / \gamma_c = 0.26$$

$$k = 1.6 - d = 1.4$$

$$\rho_1 = A_s / b_w d = 0$$

$$\sigma_{cp} = N_{sd} / A_c = 0$$

$$V_{cd} = 0.26 * 1.4 * 1.2 * 30 * 200 = 2.62 kN$$

The contribution of the steel fibres is given by the following formula.

$$V_{fd} = k_f * \tau_{fd} * b_w * d$$

$$k_f = 1 + n * (h_f / b_w) * h_f / d$$

$$n = \frac{b_f - b_w}{h_f} = \frac{175 - 30}{25} = 5.8 \text{ where } n \leq 3, \text{ so } n=3$$

$$k_f = 1 + 3 * \left(\frac{25}{30}\right) * \left(\frac{25}{200}\right) = 1.31$$

$$V_{fd} = 1.31 * 0.25 * 30 * 200 = 1.97 kN$$

The Dramix guidelines state if the fibres are the only shear reinforcement, which is the case, half of the shear force has to be absorbed by the fibres. The maximum permissible shear resistance of the beam is therefore

$$V_{total} = 2 * 1.97 = 3.94 kN \quad \text{or} \quad \tau = \frac{3.94 \cdot 10^3}{30 * 200} = 0.65 N / mm^2$$

As can be seen in the previous chapter the maximum load is 0.59 N/mm<sup>2</sup> so the capacity exceeds the load ( $M_u > M_d$ ).

#### 7.3.4 Moment capacity of the column

The column is made of normal concrete with normal reinforcement. The quality is presumed to be the same as the concrete used for the fibres, B25. The reinforcement has a cover of 20 mm. Normally this wouldn't be sufficient, but because they are totally surrounded by concrete it is. The column has a trapezium shape with a dept of 110mm and a width of 180 mm on one side and 200 mm on the other side. It has some openings for the installation of the elements, which leave a cross-section of 110 mm x100 mm. It is reinforced with four steel bars with a diameter of 12mm and yield strength of  $f_y=460N/mm^2$  (normal reinforcement steel in Kenya).

$$A_s = 2 * 113 = 226 mm^2$$

$$F_s = 226 * 460 = 104 kN$$

$$d = 110 - 20 - 0.5 * 12 = 84 mm$$

$$z = 0.85 * d = 71mm$$

$$M_d = F * z = 104 * 0.071 = 7.38kNm$$

As can be seen in the previous chapter the maximum load is 5.92 kNm so the capacity exceeds the load ( $M_u > M_d$ ).

The pressure on the concrete also has to be checked.

$$A_b = 0.39 * d * b_b = 0.39 * 84 * 100 = 3276mm^2$$

$$M_u = 5.92kNm$$

$$F_s = 5.92 / 0.071 = 83.4kN$$

$$\sigma_b = F_s / A_b = 104 / 3276 = 25N / mm^2$$

The quality of the concrete is B25, so the concrete is able to withstand this load.

### 7.3.5 Shear force capacity of the column

There is no shear reinforcement in the columns, so the concrete contributes to the shear capacity. Again the shear capacity is chosen according to the Eurocode 2. Due to the fact that the roof can be made of corrugated steel sheets no normal force will be taken into account.

$$V_{cd} = \{ \tau_{Rd} * k * (1.2 + 40\rho_1) + 0.15 * \sigma_{cp} \} * b_w * d$$

$$\tau_{Rd} = 0.25 * f_{ctk,ax} / \gamma_c = 0.26$$

$$k = 1.6 - d = 1.6 - 0.085 = 1.5$$

$$\rho_1 = A_s / b_{wd} = 312 / (110 * 180) = 0.016$$

$$\sigma_{cp} = N_{sd} / A_c = 0$$

$$V_{cd} = \{ 0.26 * 1.5 * (1.2 + 40 * 0.016) \} * 110 * 180 = 14.2kN$$

As can be seen in the previous chapter the maximum load is 4.3 kN so the capacity exceeds the load ( $M_u > M_d$ ).

For the drawings and pictures of the element with exact dimensions see appendix 7, for the design of the foundation see appendix 8.

## 7.4 Tests

### 7.4.1 general

The results of the test are listed in the attachment 5. In the next paragraph a short explanation of the test methods are described.

### 7.4.2 Cube crushing

For the actual production of pilot elements it was necessary to design a concrete mixture with the desired strength, in this case an characteristic strength of  $25 \text{ N/mm}^2$ , which corresponds with a average strength of  $33 \text{ N/mm}^2$ . Because the research time was limited, a curing time of 7 days was chosen which is extrapolated to a 28 days strength.

For each designed mix the contents of the mix are represented and the results from the crush test are given in the attachment 5.



28 | Cube crushing

At the start of the test of different mixtures, the slump and the spread test were done to check the workability. But even though these tests indicated that the mix would not be workable it was easy to cast. Even with different mix designs the values for the slump and the spread test didn't change. An assumption was made that this had something to do with the added fibres and therefore these tests weren't preformed in the process of mix design.

For the tested to mixtures were made. The extrapolated 28 days compression strength was  $31,6 \text{ N/mm}^2$  and  $32,8 \text{ N/mm}^2$

### 7.4.3 Compression on the element

For the compression test use of a steel beam was necessary to distribute the loading over the element simulating a distributed load. Due to bending of the steel beam the load was not entirely uniform distributed. The beam failed below the loading point of the machine. Probably the element can resist a higher load with a real uniform load distribution.

This test was done in order to check if it was possible to stack the elements on top of each other. The loading that leads to failure is  $415 \text{ kN}$ , and the weight of one element

is roughly 1kN. From this it can be concluded that you can easily build multi-storey building with the elements.

#### 7.4.4 Bending element

Three point bending test over the strong axis and weak axis. The span between the supports is 1,14m.

On one of the elements three strips are fixed on both sides near the constraints to measure the displacements. The strips are fixed at 0.37 meter from the middle of the element. The strips are placed in a manner which results in a measurement of the displacements in horizontal, vertical and diagonal (45 degrees) direction. This is expressed in figure A. The displacement results will be used for future activities, but not for this report.

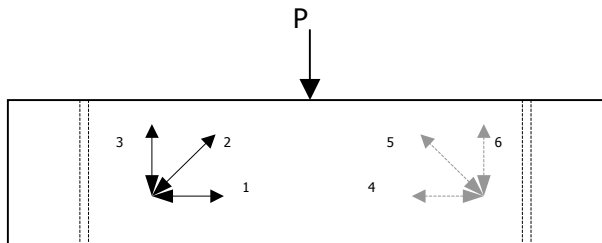
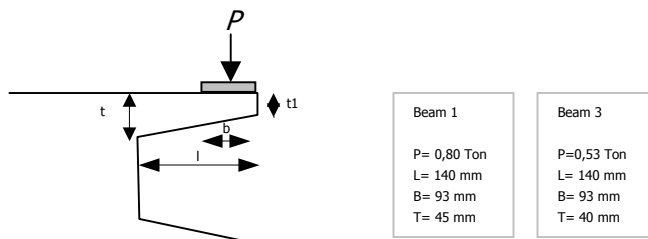

Figure A

The loading force which leads to failure is 26683 N, which is more than ten times as large as the maximum loading over the weak axis. The load that the construction should withstand in this direction is the same as over the weak axis (307Nm), so the element can withstand the loads.

#### 7.4.5 Bending wing element



This test was done in order to check the strength of the wings. But with these tests was shown the wings could carry at least 0.5 ton, which is five times the self weight of the element. This resulted in the conclusion that the wings of the elements would be able to withstand the loads which occur during handling.

#### **7.4.6 Schmidt hammer test**

The Schmidt hammer test is not an accurate test, but the test provided information about the used concrete and the uniformity of the quality. The test points are random taken on the element.

The difference in quality between the sides of an element is about 25 %. The difference in quality between the elements mutually is maximum 40 %. From this test it is clear that the quality of the concrete is constant over the element.

# 8 Production of precast sfrc-elements

## 8.1 Mould design

### 8.1.1 Considerations for the mould design

For the mould several considerations have to be made:

- Choice of mould material;
- Choice of mould type;
- Points of attentions for design and casting

#### *MOULD MATERIAL*

The material used for the mould will be steel. The choice is based on the following considerations:

- ✓ Steel is more available than timber;
- ✓ The surface of the concrete must be straight;
- ✓ Maintenance costs; in Kenya maintenance is not often applied;
- ✓ The number of casts in the same mould is large ( $\pm 500$  casts);
- × A disadvantage of a steel mould is the less adaptability of a steel mould;
- × High investment costs.

#### *MOULD TYPE*

A mould can be designed in two manners: fixed and demountable. The demountable types can be divided into four different variants: table form for plate shaped elements; battery mould to produce plate shaped elements in vertical direction; continuous moulds; digital wax moulds

The design for plate shaped elements requires a table form. The continuous and digital wax moulds are not possible, because of the execution and the high costs. The battery mould is not possible because of the small dimensions of the elements and the elements causes vibration problems. In Europe finishing is labour intensive and therefore relative expensive, but in Kenya labour is not expensive. Therefore a large finishing side, in comparison to the height of the mould, is not an issue.

Because of the present production of elements with table form moulds, there is experience to handle and solve problems.

*POINTS OF ATTENTIONS FOR DESIGN AND CASTING*

- For aesthetic reasons and in order to reduce damages at edges of precast concrete units should be designed with a reasonable radius or chamfer (no sharp corners). To provide an edge with a width of 14,1 mm, the corner are reduced with 10 mm;
- Simplicity of the mould, less connections;
- The order of the mould must be flexible to get an economical design; The necessary changes in the design can be accomplished through adding mould pieces or replacing head or side boards. This can be used for necessary texture or window or door elements;
- For the columns it is required to have a profiled foot. (the foundation must have profiled sleeves);
- To simplify the pouring of the element (small spaces), to solutions are given:
  - Making an equipment (funnel) for preventing of damaging the Styrofoam, see figure 29a;
  - Designing a turn over in the side unit of the mould, see figure 29b.

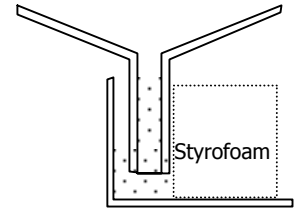

29a | Pouring with tool

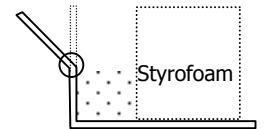

29b | Pouring with separated side of mould

Decision:            designing a turn over, because of the too small spaces (25 mm)

- Because of the hinge at the wall unit, it is necessary to introduce a fake edge to hide the unevenness in the element surface after casting

**8.1.2 Mould design of façade element**

The mould should be made for two types of façade elements:

- Wall element;
- Door- or window element.

For the design several problems have to be solved. In the next paragraph the problems are listed:

- The Styrofoam block must fit in the element. And the necessary space must be guaranteed. The block must be fixed in the mould. The Styrofoam block will be fixed with steel pins;
- The contact surface between Styrofoam and concrete must be tight. No air must be enclosed;
- No concessions are made to the design of the element
- The mould must be able to adapt to smaller elements, because of economical reasons;
- Cleaning of the mould after demoulding;



- Handling and transportation of the moulds. And the moulds must be capable to pile up. If the mould is too heavy to transport by hand, the bottom plate can be designed with fibreglass. But this is more expensive;
- The stiffness of the bottom and wall must be checked, and in case of low stiffness strengthening must be welded.

### *MOULD SECTIONS*

- Bottom plate;
- Wall plates, two different profiles;
- Support construction;
- Top plate.

Extra:

- Block, to fabricate door and window elements (assumption the width of the windows is equal to the width of doors);
- Steel pins (small diameter) welded in lengthways on of the bottom plate (3 times) and on the end plates. The pin will be stuck in the Styrofoam to fix it;
- Equipment for demoulding of the moulds;
- To equip the elements with texture, the side plates can have texture;
- For handling and placing from the elements it is necessary to provide equipment;
- Bolts and nuts for connecting the mould sections.

### *CASTING PROCEDURE*

The elements can be casted in to ways, horizontal or vertical.

Horizontal casting

- Cast the bottom layer of 25 mm. It is necessary to calculate the amount of concrete to have an exact thickness.
- Vibration; because of several times of vibration, during casting of one element; the vibration time must be short.
- Adding Styrofoam and fixing it with the steel pins. The interspaces between the Styrofoam and mould must be exact. The Styrofoam block must be load with a weight, to have pressure onto the surface of concrete to avoid enclosing of air. (If still air is included, the Styrofoam must be perforated.)
- First the interspaces must be filled. Attention must be given to the filling, so the Styrofoam will not be moved or damaged.
- Pouring the last layer and vibration.

Vertical casting

- placing the Styrofoam onto the bottom (design) and fixing it with the pins
- with a special tool (see header equipment) the concrete must be poured.
- when the mould is filled the mould must be vibrated

Decision: designing the mould with vertical casting.

The main disadvantage of horizontal casting is the difficulty with the exact thickness of the layer. The workmen have to add the right amount of concrete; otherwise implementation of the elements is not convenient with the design. Because of this main problem, the elements will be casted in vertical way.

### *PLACING*

Because of the weight measures have to be taken in the element for easy lifting. Or special equipment has to be made for lifting.

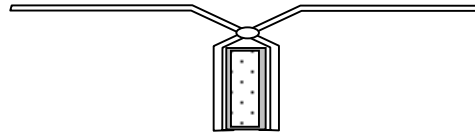

30 | Handling tool for placing the element

### Equipment

- Erecting tool, see figure 30;
- Casting funnel for guide the concrete into the small groove between mould and Styrofoam. And to prevent that the fibres will stuck in the Styrofoam.

### 8.1.3 Mould design for the Columns

Two types of columns have to be made:

- Link column
- Corner column

The link column is used for the stability of the wall and forms the connection between the elements, the shape is simple rectangular. The corner column can be design in four different ways. Three of the alternatives (a,b,c) are too heavy, according to the requirements (100 kg). So the last alternative (d) is the only possible solution. The corner can be finished in several ways: with a corner element; with plaster; or with a steel profile. For the design there will be assumed a finishing element designed.

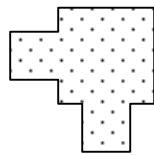

31 | Possibilities for the corner element

a | too heavy

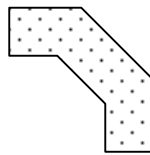

b | too heavy

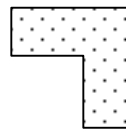

c | too heavy

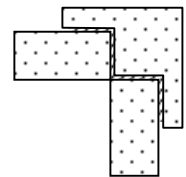

d | best

The construction of the corner columns is reflected in the drawings. The corner columns will be constructed with a demountable mould.

For the design of the columns we chose for the fixed form.

For the design several problem have to be solved. In the next paragraph the problems are listed:

- The reinforcement must be fixed in the mould with some simple equipment;
- The connection between column and foundation is casted in-situ;
- The basis of the column must be profiled. The only concession to be made is that one side of the column can not be profiled, because of a fixed mould;
- It is not necessary to have protruding reinforcement;
- Facility for a connection between timber trusses and column.

#### *MOULD PARTS – LINK COLUMN*

- Tub plate for the mould;
- Support construction.

#### *Extra:*

- Support construction to fix the reinforcement at the right place;
- Hole for a connection between timber trusses and column;
- Profiled mould for about 300 mm (the hole in the foundation must also be profiled, to generate compression areas between column and foundation), see appendix 8 for explanation.

## *MOULD PARTS – CORNER COLUMN*

This element is no structural issue. The element is just for finishing.

Because of the shape of section the mould must be demountable. The mould units are:

1. Bottom plate
2. Wall plates, three different profiles
3. Support construction

*Extra:*

1. Profiled mould for about 300 mm (the hole in the foundation must also be profiled, to generate pressure areas between column and foundation)
2. The corner element must be fixed to the foundation and at the top, because of lack of external reinforcement.

## *CASTING PROCEDURE FOR COLUMNS*

The procedure can only be done in horizontal way, because of the support construction for the reinforcement, the element can be casted in one phase.

1. Fixation of the reinforcement in the mould
  - Casting
  - Vibration
  - Finishing

### **8.1.4 Manufacturing of the mould**

The wall elements are the most important parts of the façade, because of that only the mould for the element is designed. The columns have a more easy shape. So up to now only a (temporary) mould for the elements is produced.

## *FINAL MOULD DESIGN*

*The process*

- First a concept design was made by hand;
- After discussing with technicians from the university a new design was made with the computer (2D and 3D);
- This design is adjusted during the process of manufacturing to a final design.

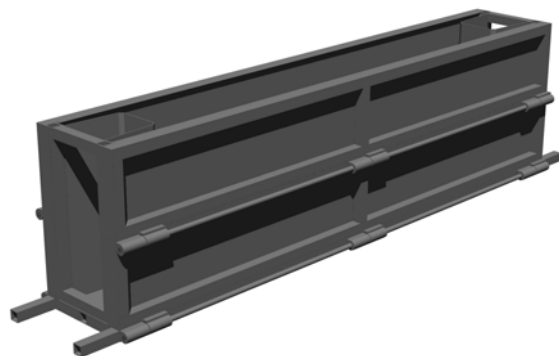

32 | Mould (also see appendix 7)

The final mould design exists of 6 parts in total (2 end part, 2 side parts, 1 bottom plate and 1 top plate).

### *Materials used for the mould*

- For the bottom plate we used 3 mm plate;
- For the end parts we used 1.5 mm plate;
- For the other parts we used 2 mm plate;
- To avoid deformation of the mould, the steel plates are supported with steel bars.

### *Connections*

- The side parts are connected to the bottom with use of steel angles and tightened with bolts and nuts
- The side parts (two parts) of the mould are connected with to each other with hinges
- The other connections are made by drilling holes into the steel bars and tightened with use of bolts and nuts



33 | Manufacturing the moulds

### *Used equipment*

- The steel plates are cut and bended with the bending and cutting machines
- The steel plates and bars are welded to each other
- The unevenness between the different parts are flushed with a grinder (flex)

After manufacturing the moulds were painted with red oxide, which is a necessity for conservation

### *EXECUTION OF THE MANUFACTURING*

The mould manufacturing is done in one and a half week with an average cast of workmen of three per day. During the manufacturing some problems came across, because of this, good supervising was needed to be sure that everything went well.

The problems are:

- The workmen found it difficult to read the drawings, so they needed more explanation during the manufacturing (sometimes redrawn);
- The precision we desired was difficult to realise with the steel plates;
- The connections between the different parts of the mould where difficult to tighten.

### *RESULT*

The moulds were manufactured sufficient enough to satisfy the expectations.

Remark: Of one mould the hinges were removed during the casting process



34 | Produced mould (also see appendix 7)

## 8.2 Assembling, casting and demoulding

The assembling, casting and demoulding procedures are described in the next paragraph. The procedures are based on experiences from the first trial. Specific problems that occurred will be described.

The Styrofoam used for the mould is solid (6 inches). The density of the Styrofoam is 20 gram/liter.

### 8.2.1 Mould assembly

Needed time: 3 hours (for four moulds, with four persons)



35 | Mould parts

Before the moulds are assembled they have to be oiled, because after assembly there is no possibility for oiling.

Due to the fact that the moulds have a lot of loose parts the assembly is a lot of work. There is also a specific order that has to be followed in the assembled of the mould.

First the side have the be connected to the end plates, after this the total can be connected to the base plate. Now the styrofoam has to be put in place.

The Styrofoam needs to be fixed with spacers. In the trial design the Styrofoam is fixed with steel pins, welded to the mould. The solution is suitable, but labour intensive and connection vulnerable.

For water tightness of the mould rubber strips are fixed between the connections.

Short standing operation procedure for assembling of the moulds:

1. Fix the Styrofoam to the base plate; make sure the Styrofoam has the right spaces at both sides;
2. Fix the small sides to the base plate and Styrofoam;
3. Fix the long sides to small sides and the base plate, be sure of the right alignment of the parts
4. During casting the top plate must be fixed.



36 | Casting of the elements

### 8.2.2 Casting

Needed time: 1 hour (50 minutes for four moulds, with 6 persons)

Needed equipment:

1. Vibration table (simple model)
2. Shovels
3. Concrete mixer (capacity of 300 kg is enough)

4. (Lifting truck; if the moulds have extra en better handles, the moulds can be transported with persons)

The first adding of the concrete in the mould must be done carefully, because of the fact that the Styrofoam is not well fixed and the small spaces are certainly necessary. For pouring of the small spaces small shovels are required. Every vibration is less than 30 seconds.

Short standing operation procedure for pouring the moulds:

1. Fill the sides of the moulds till the top (dependent of the use of the designed hinges; during practice it was figured out that the hinges can be eliminated);
2. Vibrating;
3. Fill the mould till the top with concrete;
4. Vibration (add concrete during vibration to fill the entire mould);
5. Installation of the top plate;
6. Fill the remain mould;
7. Vibration;
8. Finishing of the concrete surface;
9. Wasted concrete must be removed from the mould, otherwise demoulding is problematic;
10. The casted mould must be labeled with a number (for administration purpose);
11. The mould must be cured in a moisture environment.

### 8.2.3 demoulding

Time: 2 hours (with five persons)

Removing the parts in reverse way of assembling. Take care of the concrete parts nearby the 'ears'; the concrete is still very weak. The elements will be cured at a sand bed. For curing of the elements the sand bed must be wetted.

Because of the low weight, an element can be lifted by two men (this also was a requirement).

Comments on mould design:

1. Bottom plate needs better design;
2. Hinges can be eliminated;
3. Rubber strips for water tightness must be excluded;
4. Instead of steel pins spacers must be designed;
5. Designing a economic mould saves a lot of assembling and demoulding time;
6. The used concrete mix must have a constant quality;
7. Extra handling tools must be added to the mould.



37 | Final result after casting and demoulding





# 9 Construction of the building

This chapter will discuss the erection of the total building that has been proposed. Although not every part is designed yet, a global order can be given.

## 9.1 Foundation and columns

The main purpose of the foundation is to clamp the columns to the floor. The clamping however will not provide large forces. That is why a reinforced foundation even may not be necessary. Another option is to dig a hole in the sandy soil, place the columns in it and fill up the left space with sand or mortar. Now the columns are steady and the floor can be poured on top of the foundation soil.

However, this placement has to be tried first to test its application. For more details see appendix 8.

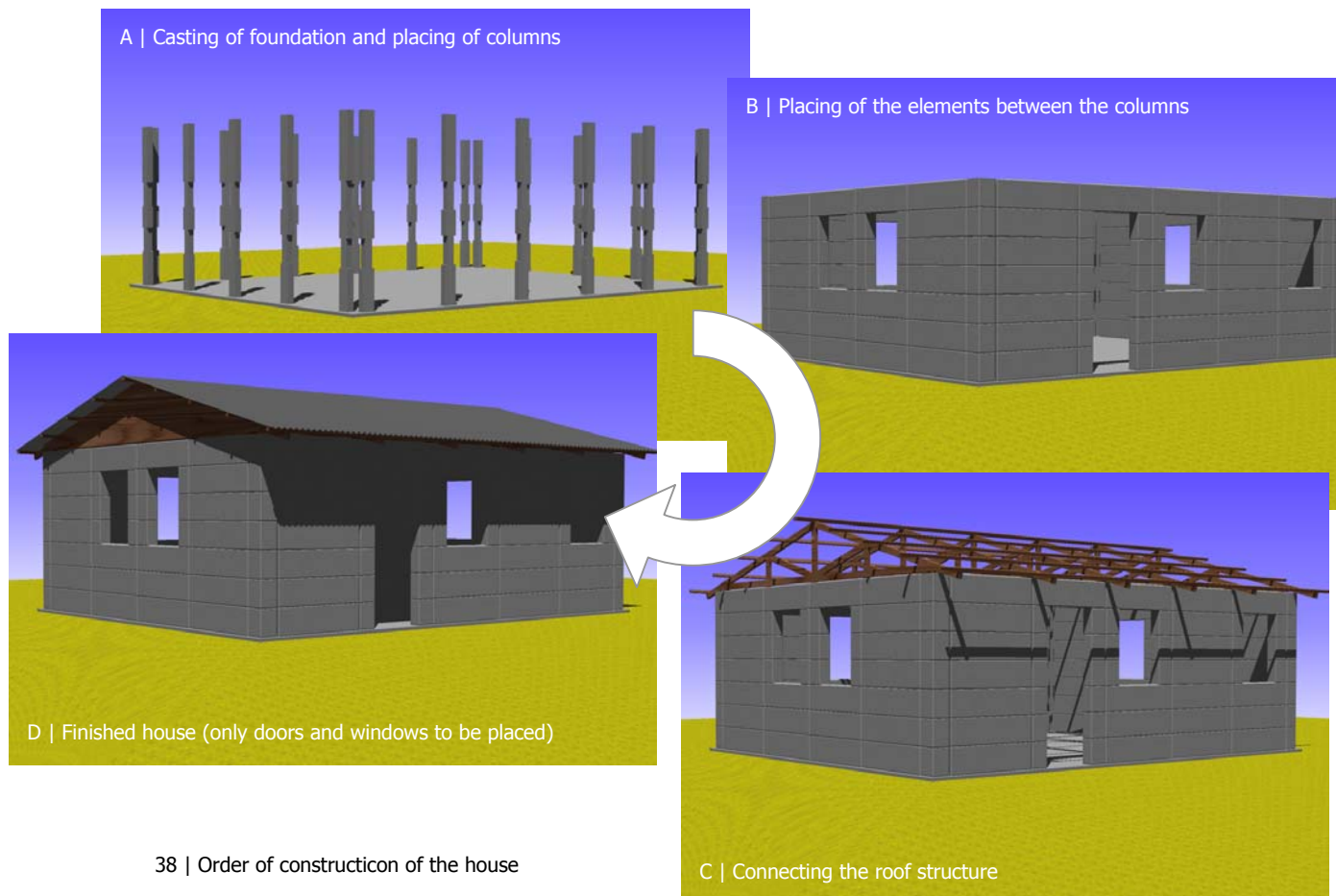

38 | Order of constructicon of the house

C | Connecting the roof structure

## 9.2 Installation of the elements

To avoid lifting the elements to the top of the columns and sliding them down from there, some savings are added to the columns at several heights. With these savings the elements can be placed between the columns by a rotating movement. Then the element is slid down only over a distance of half its own height. In every column savings are present.

Figure 39 shows the way the rotation has to be prosecuted.

The next problem with the installation is how to drop the element when it's almost at its place. The elements will be placed by at least two people by hand, when they ended sliding down the elements their fingers are still between the already present block and the block to place. When four little wooden laths are placed on top of the present element, the new element can be placed on these. When the fingers are removed the wood can carefully be taken out to place the new element on its final destination.

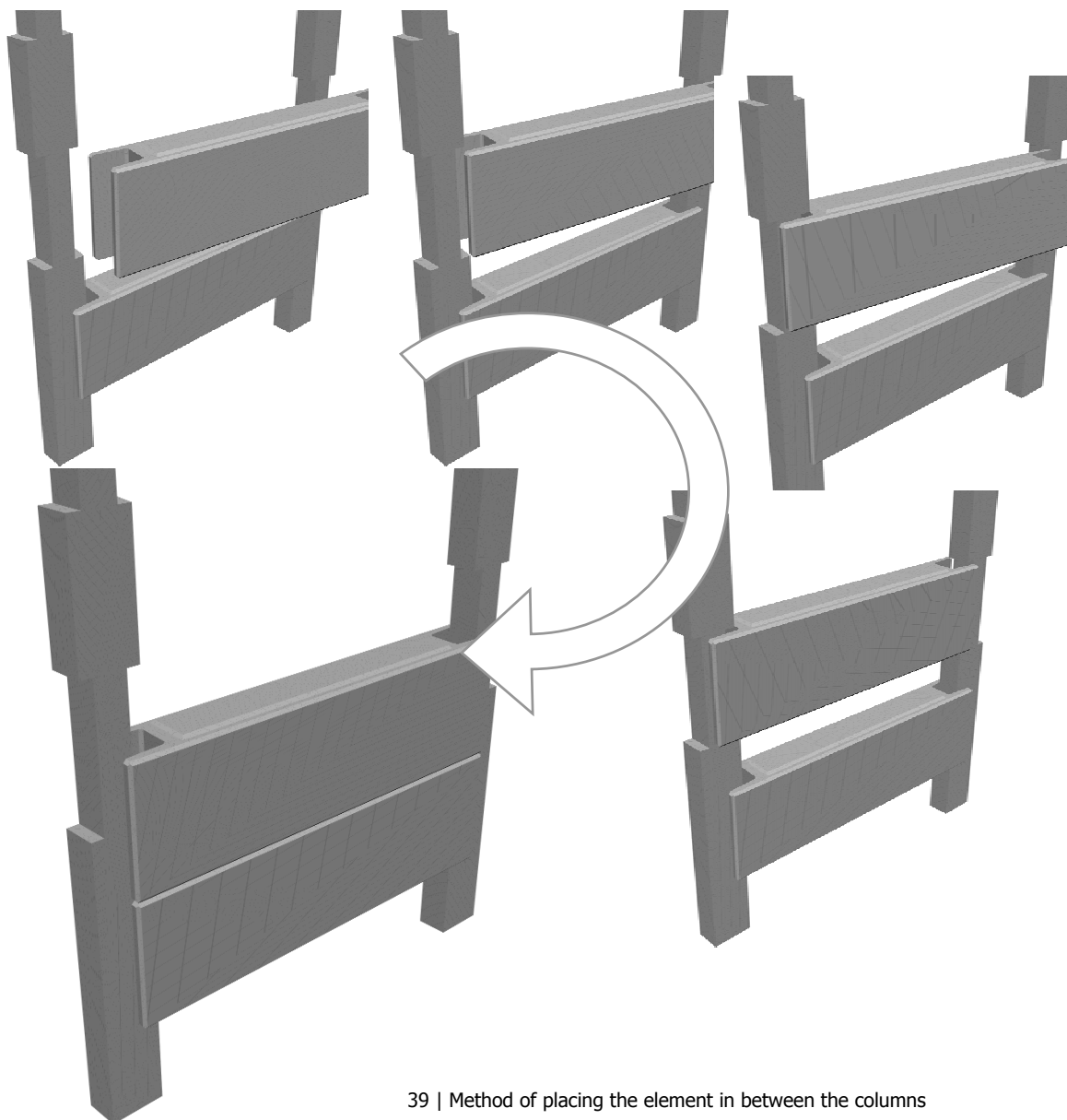

39 | Method of placing the element in between the columns

## 9.3 Roof structure

The design of the roof structure still needs improvements. The traditional way of building this part of the house in Kenya is by using a wooden truss every 1.5 meters. On this some cross beams will be placed with iron corrugated sheets on top. This however is very expensive, wood is scarce in Kenya, and the whole construction offers to much strength.

An alternative is the use of crimped sheets. Those sheets only require supports on the ends of the roof. This reduces the amount of wood and labour needed. The trusses at the ends can be connected to the columns by steel ties.

## 9.4 Costs

Maybe the most important requirement of the designed building is to make it affordable. A low total price is also required. The costs are based on information given by Bamburi, see appendix 5, visit report Bamburi Plant.

### 9.4.1 Existing alternatives

A (concrete) house build in the normal Kenyan way costs about 680,000 KSh (7200 Euro). Already two other precast systems exist, one is Eco-Homes, and the other is still in design and acts like a fence-system. The prices of these systems are respectively 790,000 KSh (8450 Euro) and 590,000 KSh (6250 Euro).

### 9.4.2 Estimation of costs for SprIT-homes

Up to now the costs of the foundation and the roof are unknown. The same holds for the internal walls of the building. This is why a good estimation of the costs can not yet be made.

However, the costs of the external walls up to now can be calculated rather exact for the present design.

The lifetime of one steel mould, a new mould with modifications to improve the speed of demoulding and casting, is about 500 casts. One house (45 m<sup>2</sup>) contains 126 elements. This means that about four houses can be made out of one mould. The price of one mould will be about 15,000 KSh (160 Euro, the mould used for the tested elements costs about 10,000 KSh, but needs to be improved). For one house the mould also costs 3750 KSh (40 Euro).

The concrete needed for one element will be about 95 kg (41 l), which costs about 6200 KSh (65 Euro) per cubic metre. The costs of concrete per element will be 265 KSh (2.8 Euro) including fibres and 170 KSh (1.8 Euro) without fibres. Which means about 34,000 KSh (360 Euro) per house.

Another material used in building the elements is styrofoam. The styrofoam used for the trial casts costs 1000 KSh (11 Euro) per sheet of 4' x 4' x 6". Out of one plate 3.5

blocks could be cutted (also 8' sheets are available, so 3.5 can be used). This makes the costs of styrofoam per element 285 KSh (3 Euro). However these costs can and have to be reduced when big amounts of styrofoam are bought or other cheaper solutions are searched for. (For example hollow styrofoamboxes or plastic boxes. The present total costs for styrofoam in one building are 36,000 KSh (380 Euro)).

The columns in the walls will be made of normal concrete, reinforced with steel bars. For the calculation of their costs the normal and with fibres reinforced concretes are assumed to be the same. This means that one column (of 150 kg, 65 l) costs 400 KSh (4.3 Euro). One building contains 22 columns, so this part of the costs is 8800 KSh (95 Euro).

At the end the costs of the walls for a 45 m<sup>3</sup> house (excluding mortar between the elements and the columns) are about 83,000 KSh (880 Euro).

## 9.5 Comparison concrete Eco-Homes and new design

To compare the costs of the new design with the existing Eco-Homes design, the quantities of concrete can be compared. When this is known you can see what savings are needed to make cheaper moulds, have reductions in the labour costs and the overall production.

In the calculations the ground floors are supposed to have the same amount of concrete.

### 9.5.1 Calculation concrete Eco-Homes

Walls: 45 m<sup>2</sup>, 6 m x 7.5 m global 27 m of wall, each 2.4 m high and 0.05 m thick. Including thickened edges, this gives 3.3 m<sup>3</sup>.

Reductions by doors (2 doors, 0.072 m<sup>3</sup> each) and windows (8 windows, 0.024 m<sup>3</sup>).

This gives a total amount of 3.0 m<sup>3</sup> of concrete.

### 9.5.2 Calculation concrete new design

Walls: 45 m<sup>2</sup>, 126 elements needed. Each element contains 0.041 m<sup>3</sup> of concrete. This gives 5.2 m<sup>3</sup>.

Reductions by doors (2 doors of 6 elements high, reduction 0.019 m<sup>3</sup> per element) and windows (8 windows of 3 elements high, reduction 0.019 m<sup>3</sup> per element).

This gives a total amount of 5.9 m<sup>3</sup> of concrete.

In the walls of the new design 99% more concrete is needed. However, there are other fields that can compensate this increase of the global costs.



# 10 Conclusion & recommendations

In this chapter the conclusions and recommendations are reflected.

## 10.1 Conclusions

The conclusions will be divided in notes towards the mix design and element design. The mix design is necessary for the element design. The element design is made for an affordable house of 45 m<sup>2</sup>.

### 10.1.1 Mix design

The mix design is based on a guideline. The guideline is according to Dutch standards. The standards are applied with knowledge of the difference in aggregates.

#### Characterises of the applied concrete mix for elements:

Portland Pozzolana cement, CEM II 32,5

Consistency is plastic

Water / cement ratio 0,47

Fibres: Dramix 45/30 RLBN

40 kg (fibres) / m<sup>3</sup> (concrete)

#### Grading (see figure 34) and amounts for an element:

Coarse aggregate (6-9 mm) 32 kg

Fine aggregate (2-6 mm) 8 kg

Sand 27 kg

Cement 21 kg

Water 10 kg

Fibres 2 kg

#### Extra requirement for sfrc concrete

About 40% of the weight of all aggregates (sand, gravels) should be sand.

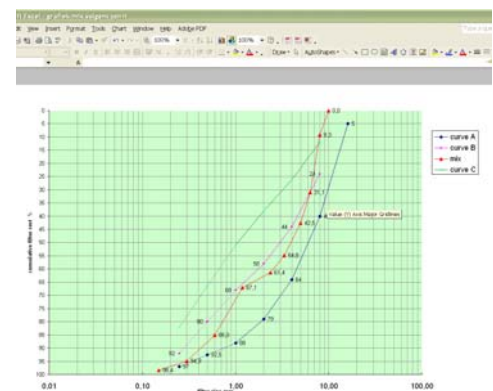

40 | Grading of the concrete mix

### Tests:

After five adaptations of the concrete mix (according to the results of crushing tests) the average compressive strength is 32,8 N/mm<sup>2</sup>. This equals a characteristic compressive strength of 25 N/mm<sup>2</sup> (B25). The density of the concrete mix is 2227 kg/m<sup>3</sup>.

### 10.1.2 Element design

The final design is based on several points of attention. The main objective is the weight of an element. The element is portable because of the low self-weight (100 kg). Two persons can carry the element. Thick walls provide a feeling of safety, because of the necessary low self-weight a false thickness is applied. The core of the element is made of a 6 inch thickness Styrofoam block. Because of clamped columns the stability during erecting is guaranteed. This also means a relatively straight positioning of the columns is necessary.

Other design considerations are the possibility for modular building, easy extension of a house in the future and a short erection time of the total house. Because of the simplicity of the construction and the element, the design could be applied in different regions of Kenya. All the considerations result in a global element design, as shown below.

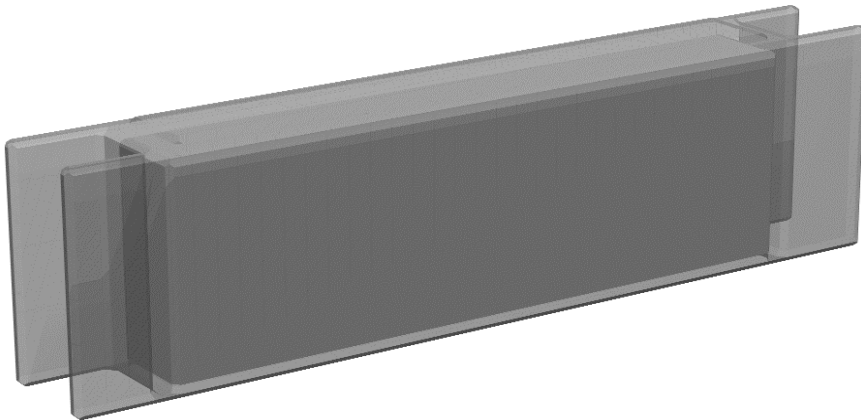

41 | The final element

The element is checked on base of several calculations. These calculations proofed that the element will easily withstand the loads. But several pilot elements are made to check the calculation with testing. To be able to produce pilot elements it was necessary to design and fabricate steel moulds. The results of the tests are listed below.

dimensions: 1475 mm x 200 mm x 400 mm  
strength: Average compression force  $35 \times 10^3$  kg  
Bending main axis  $2,7 \times 10^3$  kg, weak axis  $1,0 \times 10^3$  kg  
Wing strength  $0,5 \times 10^3$  kg



## Costs

The costs for materials are calculated for an individual element. Extra costs, for example labour costs, are not calculated.

### *Element costs*

Concrete:	260 Ksh (including fibres)
Styrofoam:	300 Ksh
Total:	560 Ksh

### *Wall costs*

The costs for the walls of the house (45 m<sup>2</sup>) are based on the amount of 126 elements. The total sum for the walls is (including column costs and machinery costs) 83.000 Ksh (880 euro).

## 10.2 Recommendations

The recommendations are separated in a part concerning the design of the used concrete mix and the materials, the element and finally the total system.

### *CONCRETE MIX AND MATERIALS*

- Experiment with other types of fibres, cost- and material effects;
- Experiment with quantities of fibres;
- Add hardeners to mix;
- Use non-solid styrofoam core;
- Use no styrofoam, make hollow inner part by adding a tapering in the mould's bottom;
- Core of waste plastic;
- Core of lava stone;
- Hollow core of ferro-cement;
- Investigate the possibility of using light weight aggregates.

### *ELEMENT*

- Normal reinforced instead of fibre reinforced concrete;
- Add brick-profile to mould on outer surface of the element;
- Reduce the notch on top, middle part not necessary, also better for placing window;
- Reduce the chamfer to 0.5 x 0.5 cm, this still looks good and reduces the grooves in the facade;
- Use concrete spacers to replace the pins in the mould, to keep the styrofoam in place;
- No hinges in the mould (long side parts not divided in two parts);
- Use clamps in stead of nuts and bolts for the mould (faster (de-)moulding);
- Test elements at full 28 days strength;

- Use of thicker steel plates for the mould to reduce the necessary nuts and bolts.

#### *TOTAL SYSTEM*

- Instead of a precast column cast the column in-situ after stacking up the elements;
- Clamp column in the soil instead of the concrete foundation;
- Make column of steel fibre reinforced concrete;
- Replace corner elements by plaster;
- Review tolerances carefully to look for possible reductions, but do not forget the necessary space for rotating the elements during placing;
- Use precast floors to exclude casting on site;
- Check the water and wind tightness;
- Change the roofing system (for example "crimped sheets") to reduce costs;
- Make the inner walls of cheaper materials.

# Literature

## *BOOKS, LECTURES AND REPORTS*

- Allen, A.H., *Reinforced concrete design for BS 8110*, Chapman & Hall, Spon Press, London (England), 2001.
- Ecohomes Ltd, *Installation manual for the ecohomes concept*, Kenya, July 2003.
- Fraaij, dr.ir.A, *Handleiding Beton oefening Materiaalkunde*, Delft (The Netherlands), 2000.
- Gorys, E., *Merian live! Kenia*. Brussels (Belgium): Deltas, 1999.
- Harlow, *Pearson Education Asia Pte.ltd*, 2000.
- Kenyan Bureau of Standards (KEBS), *Cement-Part 1 Composition, Specification and conformity criteria for common cements*, Kenya, 2001.
- Lok, T.S., *3<sup>rd</sup> Asia-Pacific specialty conference fibre reinforced materials*, Singapore, November 2003.
- Neville, A.M, *Properties of concrete*, fourth edition.
- Nieuwenhuizen, J. *Hogere bouwkunde – woningbouw*. Jellema, 2002.
- Nyonboi, Mr T, *Stress-strain relations for steel fibre reinforced concrete beams in shear*, Moi University Eldoret (Kenya), 2003.
- Odinga, Hon. Eng. R.A., *Affordable housing – Investors Meeting*, Ministry of roads public works & housing, Kenya, 2004.
- Schwarz, B., *Nelles Guide Kenia*. 3<sup>rd</sup> print. Gorenjski Tisk (Slovenia): Günter Nelles, 2002.
- Vambersky, Prof. Dipl. J.N.J.A., *designing precast elements*. Delft (The Netherlands): TUD, 2003.
- Walraven, Prof. J.C., *designing concrete structures*, Delft (The Netherlands): TUD, 2003

## *MAGAZINES*

- Dramix Guideline: Design of concrete structures – steel wire fibre reinforced concrete structures with or without ordinary reinforcement, excerpt of the magazine 'infrastructuur in het milieu' nr. 4, 1995
- Dramix Design guidelines for Dramix steel wire fibre reinforced concrete, 2000
- Holschemacher, Prof. Dr. K, *Zukunftsperspektiven eines innovativen Baustoffs*, Leipzig (Germany), HTWK, BetonWerk International nr.1, feb 2003.

*INTERNET*

<http://www.bekaert.com/building>

<http://www.novocon.com>

<http://www.mu.ac.ke>